

Mechanical Linear Drives
HSB-beta®

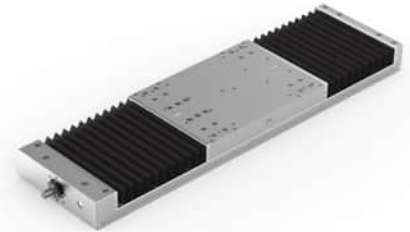

Compact Modules
HSB-delta®



Linear Tables
HSB-alpha®

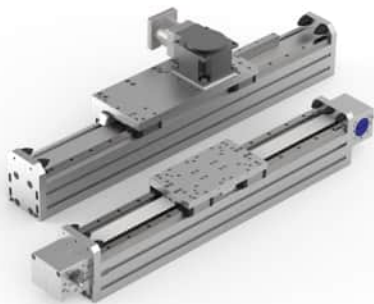

Portal Linear Drives
HSB-gamma®



Portal Linear Drives
HSB-sigma®



Ball Screws
HSB-kgt®



Handling Systems

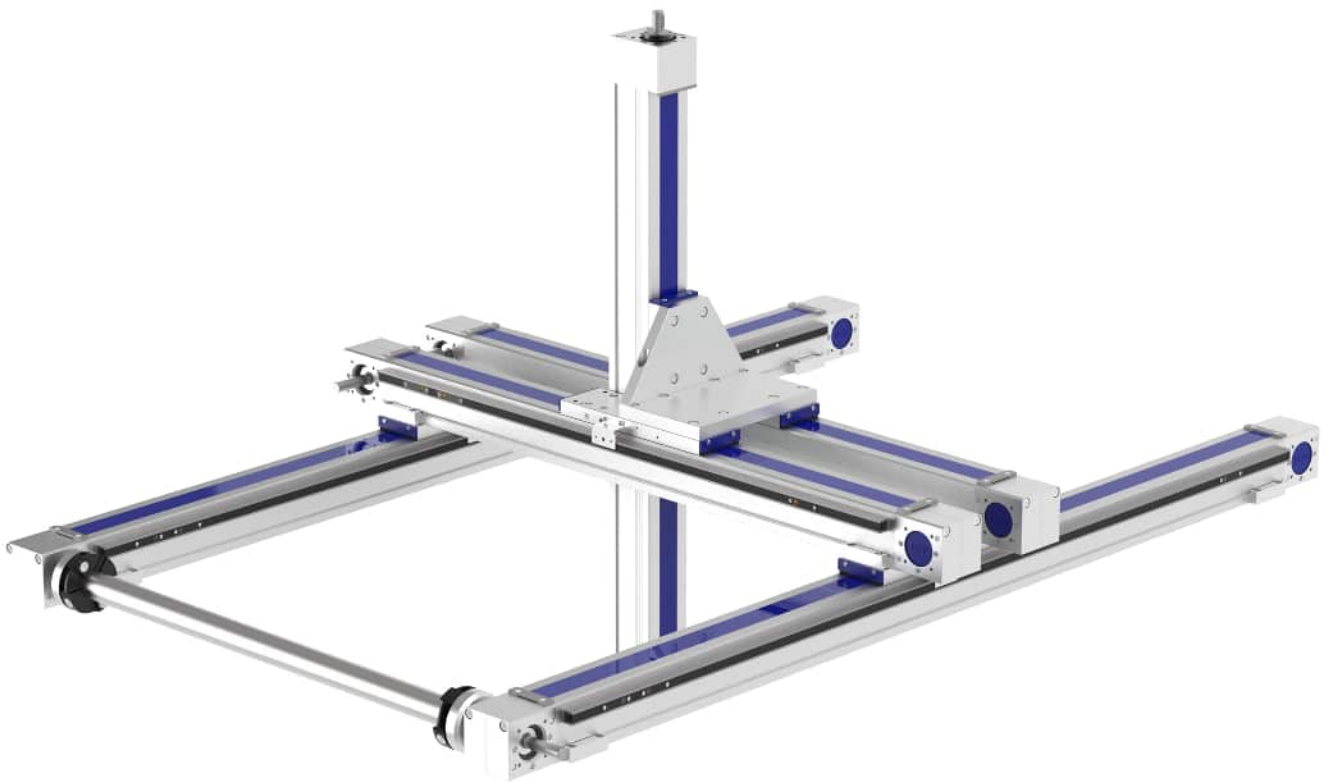

This 3-axis system consists of:

4x HSB-beta[®] 80-ZSS and
1x HSB-beta[®] 80-SSS

Complete Catalogue

Print: December 2024

All specifications are subject to change without prior notice.

Notes and drawing

Page	Series	Size	Description
13 – 15			Performance Overview of Linear Drives, Linear Tables
IB-beta			
B1 – B2	Beta	40	Mechanical Linear Drive
B3 – B5	Beta	50-C	Mechanical Linear Drive
B6 – B7	Beta	60	Mechanical Linear Drive
B8 – B10	Beta	70-C	Mechanical Linear Drive
B11 – B15	Beta	80(-C)	Mechanical Linear Drive
B16 – B19	Beta	100(-D)	Mechanical Linear Drive
B20 – B23	Beta	110(-C)	Mechanical Linear Drive
B24 – B26	Beta	120(-C)	Mechanical Linear Drive
B27 – B32	Beta	140(-C)	Mechanical Linear Drive
B33 – B37	Beta	165(-C)	Mechanical Linear Drive
B38 – B43	Beta	180(-C)	Mechanical Linear Drive
B44	Beta		Right-Left Version
B45 – B49	Beta		Profile Dimensions
B50	Beta		Sliding blocks (NS) and mounting brackets (BL)
B51 – B52	Beta		Ordering Code for Mechanical Linear Drives
IB-delta			
D1 – D2	Delta	90	Compact Module
D3 – D4	Delta	110-C	Compact Module
D5 – D6	Delta	145-C	Compact Module
D7 – D8	Delta	200	Compact Module
D9 – D12	Delta	240(-C)	Compact Module
D13	Delta		Right-Left Version
D14 – D15	Delta		Profile Dimensions
D16	Delta		Sliding blocks (NS) and mounting brackets (BL)
D17 – D18	Delta		Ordering Code for Compact Module
IB-alpha			
A1	Alpha	15-B	Linear Table
A2	Alpha	20-B	Linear Table
A3	Alpha	30-B	Linear Table
A4	Alpha	35-B	Linear Table
A5	Alpha		Right-Left Version
A6	Alpha		Profile Dimensions, Sliding Blocks (NS) and Mounting Brackets (BL)
A7	Alpha		Ordering Code for Linear Table
IB-gamma			
G1 – G5	Gamma	90	Portal Linear Drive
G6 – G10	Gamma	120	Portal Linear Drive
G11 – G15	Gamma	160	Portal Linear Drive
G16 – G22	Gamma	220	Portal Linear Drive
G23 – G25	Gamma	280	Portal Linear Drive
G26	Gamma		Profile Dimensions
G27	Gamma		Profile Dimensions / Sliding Blocks (NS)
G28 – G29	Gamma		Ordering Code for Portal Linear Drive

Table of Contents

Page	Series	Size	Description
HSB-sigma			
S1 – S3	Sigma	70	Portal Linear Drive
S4 – S7	Sigma	90	Portal Linear Drive
S8 – S11	Sigma	120	Portal Linear Drive
S12 – S15	Sigma	160	Portal Linear Drive
S16	Sigma		Profile Dimensions
S17	Sigma		Sliding blocks (NS) and mounting brackets (BL)
S18	Sigma		Ordering Code for Portal Linear Drive
Z1	Accessories		Ordering Code for Limit Switches (EN), Drive Shafts (AZ)
Z2	Accessories		Deflection Belt Drive (URT)
Z3 – Z4	Accessories		Bevel Gear (KRG)
Z5	Accessories		Joint shaft (GX)
Z6	Accessories		Pillow bearing (SL)
Z7	Accessories		Motor Mounting/Coupling (MGK)
X1 – X3	Custom Designs		Custom Designs
TL1 – TL2	Technology Linear		Examples of Multi-Axis Systems
TL3	Technology Linear		Our Products
TL4	Technology Linear		General technical information
TL5 – TL10	Technology Linear		Design Fundamentals
TL11 – TL13	Technology Linear		Technical Data for Guides and Ball Screws
TL 14 – TL 16	Technology Linear		Maximum Drive Torques
TL17	Technology Linear		Maintenance
HSB-kgf			
K1	KGT		Rolled ball screw spindles
K2	KGT		Cylindrical ball screw nuts HSB (KGM-M)
K3 – K4	KGT		Ball screw flanged nuts HSB (KGM-F) (to DIN 69051-5)
K5	KGT		Ball screw double nuts HSB (KGM-MM and KGM-FM)
K6 – K8	KGT		Standard end machining
K9	KGT		Ordering code
TK1	Technology KGT		General technical specification
TK2 – TK4	Technology KGT		Calculations
TK5	Technology KGT		Installation
TK6	Technology KGT		Maintenance

Performance Overview of Mechanical Linear Drives and Compact Modules with Toothed Belt Drive

Description	Toothed belt	F _x [N]	F _y [N]	F _z [N]	-F _z [N]	M _x [Nm]	M _y [Nm]	M _z [Nm]	M _{idle} [Nm]	d _s [mm]	S _{max} [mm]	L _{max} [mm]
Beta 40-ZGS	16 AT5-E	500	80	150	75	6	6	8	0.30	0.08	2780	3000
Beta 40-ZSS	16 AT5-E	500	500	600	300	12	30	30	0.30	0.08	1850	2070
Beta 50-C-ZRS	20 AT5-E	700	300	600	400	30	50	50	0.40	0.08	7710	8000
Beta 50-C-ARS	20 AT5-E	700	300	600	400	30	50	50	1.50	0.08	7710	8000
Beta 60-ZSS	25 AT5-E	850	500	1400	800	50	160	100	1.10	0.08	7620	8000
Beta 70-C-ZRS	32 AT5-E	1100	300	1000	400	35	120	50	1.20	0.08	7640	8000
Beta 70-C-ZSS	32 AT5-E	1100	600	1800	1200	60	180	120	1.20	0.08	6840	7200
Beta 70-C-ARS	32 AT5-E	900	300	1000	400	35	120	50	1.00	0.08	7640	8000
Beta 70-C-ASS	32 AT5-E	900	600	1800	1200	60	180	120	1.00	0.08	7640	8000
Beta 80-ZRS	32 AT5-E	1350	500	1500	800	50	180	100	1.50	0.08	7600	8000
Beta 80-ZSS	32 AT5-E	1350	800	3000	2000	100	250	250	1.50	0.08	7600	8000
Beta 80-C-ZRS	32 AT10	2200	1000	2500	1500	100	300	180	1.80	0.08	7600	8000
Beta 80-C-ZSS	32 AT10	2200	1600	4000	3000	300	500	500	1.80	0.08	7600	8000
Beta 80-C-ARS	32 AT10-E	1300	1000	2500	1500	100	300	180	1.80	0.08	7590	8000
Beta 80-C-ASS	32 AT10-E	1300	1600	4000	3000	300	500	500	1.80	0.08	7590	8000
Beta 100-ZRS	40 AT10	2800	1000	2500	1200	200	250	200	2.50	0.08	7420	7900
Beta 100-ZSS	40 AT10	2800	1000	3000	2000	200	300	300	2.50	0.08	7420	7900
Beta 100-D-ZSS	40 AT10-E	1500	1800	4000	3000	350	750	750	5.00	0.08	7720	8100
Beta 100-D-ASS	40 AT10-E	2200	1800	4000	3000	350	950	950	2.50	0.08	7680	8100
Beta 110-ZRS	50 ATL10	4000	2000	5000	2500	300	600	450	3.50	0.08	7520	8100
Beta 110-ZSS	50 ATL10	4000	3000	8000	4000	400	800	600	3.50	0.08	7520	8100
Beta 110-ARS	50 AT10-E	2000	2000	5000	2500	300	600	450	3.50	0.08	7440	8100
Beta 110-ASS	50 AT10-E	2000	3000	8000	4000	400	800	600	3.50	0.08	7440	8100
Beta 120-ZRS	50 ATL10	4000	2500	6000	3000	350	700	500	3.20	0.08	7520	8100
Beta 120-ZSS	50 ATL10	4000	3000	8000	4000	400	1200	600	3.20	0.08	7520	8100
Beta 120-C-ZSS	60ATL10	4800	4000	12000	6000	600	1500	1000	4.50	0.08	7500	8100
Beta 140-ZRS	50 AT10-E	4000	2500	5000	3000	350	700	500	3.50	0.08	7540	8100
Beta 140-ZSS	50 AT10-E	4000	2500	6000	4000	500	1000	1000	3.50	0.08	7540	8100
Beta 140-ARS	50 AT10-E	2500	2500	5000	3000	350	700	500	3.50	0.08	7380	8100
Beta 140-ASS	50 AT10-E	2500	2500	6000	4000	500	1000	1000	3.50	0.08	7470	8100
Beta 140-C-ZSS	50 AT10-E	4000	3200	7500	5000	600	1200	1200	3.50	0.08	7470	8100
Beta 140-C-ASS	50 AT10-E	2500	3200	7500	5000	600	1200	1200	3.50	0.08	7470	8100
Beta 165-ZSS	75 ATS15	10000	5000	15000	8000	700	1400	1100	12.00	0.08	6920	7700
Beta 180-ZSS	75 AT10	6000	6000	12000	6000	1500	3000	1500	8.00	0.08	5500	6200
Beta 180-ASS	75 AT10	3500	6000	12000	6000	1500	3000	1500	8.00	0.08	5470	6200
Beta 180-C-ZSS	75 AT10	6000	8000	15000	8000	1800	3600	1800	8.00	0.08	5500	6200
Beta 180-C-ASS	75 AT10	3500	8000	15000	8000	1800	3600	1800	8.00	0.08	5470	6200
Delta 90-ZRS	32 AT5-E	800	500	1000	1000	60	80	80	1.50	0.08	3720	4000
Delta 110-C-ZSS	50 AT5-E	1100	1200	3000	1500	500	550	550	2.00	0.08	7820	8100
Delta 145-C-ZSS	60 AT5-E	2000	2500	5000	3000	800	1000	1000	3.00	0.08	7700	8100
Delta 200-ZSS	75 AT10	6000	5000	8000	5000	3500	4300	3200	6.80	0.08	1520	2000
Delta 240-ZSS	50 AT10-E	2500	6000	12000	8000	4500	6000	4500	5.50	0.08	2550	3000
Delta 240-C-ZSS	60 ATL10	3800	6000	12000	8000	4500	6000	4500	5.50	0.08	7540	8000

For mechanical linear drives with roller guides, the static load rating (C_{stat} page TL11) applies for static loads.

- M_{idle} = Idle torque ±30 %
- d_s = Repeat accuracy ±
- S_{max} = Maximum standard stroke length (longer on request)
- L_{max} = Maximum standard length (longer on request)

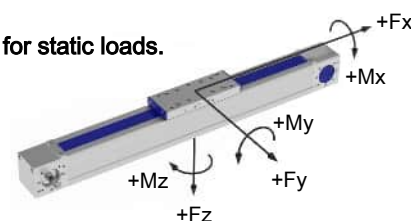

Description	Screw Drive	F _x [N]	F _y [N]	F _z [N]	-F _z [N]	M _x [Nm]	M _y [Nm]	M _z [Nm]	M _{tbl} [Nm]	d _{pn/ps} [mm]	d _s [mm]	SA	S _{max} [mm]	L _{max} [mm]
Beta 40-SGS	1205 / 1210	1000	80	150	75	6	6	8	0.3	0.08 / 0.03	0.03	2	1840	2040
Beta 40-SSS		1000	500	600	300	12	30	30	0.3	0.08 / 0.03	0.03	2	1840	2040
Beta 50-C-SRS	1205 / 1210	1000	300	600	400	30	50	50	0.3	0.08 / 0.03	0.03	-	860	1090
Beta 60-SSS	2005 / 2010	4000	600	1800	1200	60	180	120	0.7	0.08 / 0.03	0.03	8	5220	5500
Beta 60-SGV	2020 / 2050	4000	-	-	-	-	-	-	0.7	0.08 / 0.03	0.03	8	5220	5500
Beta 70-C-SRS	1605 / 1610	2000	300	1000	400	35	120	60	0.35	0.08 / 0.03	0.03	8	3725	4000
Beta 70-C-SSS	1620 / 1640	2000	600	1800	1200	60	180	120	0.4	0.08 / 0.03	0.03	8	3725	4000
Beta 80-SRS	2005 / 2010	4000	500	1500	800	50	180	100	0.6	0.08 / 0.03	0.03	8	5220	5600
Beta 80-SSS	2020 / 2050	4000	800	3000	2000	100	250	250	0.8	0.08 / 0.03	0.03	8	5220	5600
Beta 80-SGV	2505 / 2510 2525 / 2550	6000	-	-	-	-	-	-	1,00	0.1 / 0.04	0.03	8	5220	5600
Beta 100-D-SSS	2005 / 2010 2020 / 2050	4000	1800	4000	3000	350	750	750	1.3	0.08 / 0.03	0.03	8	5260	5600
Beta 110-SRS	2505 / 2510	6000	2000	5000	2500	300	600	450	1,00	0.1 / 0.04	0.03	8	5120	5600
Beta 110-SSS	2525 / 2550	6000	3000	8000	4000	400	800	600	1.5	0.1 / 0.04	0.03	8	5120	5600
Beta 110-C-SGV	4005 / 4010 4020 / 4040	16000	-	-	-	-	-	-	1.5	0.1 / 0.04	0.03	6	5120	5600
Beta 120-C-SSS	3205 / 3210 3220 / 3240 3260	12000	4000	12000	6000	600	1500	1000	2,00	0.1 / 0.04	0.03	8	5120	5600
Beta 140-SSS	2505 / 2510	6000	2500	6000	4000	500	1000	1000	1.5	0.1 / 0.04	0.03	8	5120	5600
Beta 140-C-SSS	2525 / 2550	6000	3200	7500	5000	600	1200	1200	1.5	0.1 / 0.04	0.03	8	5120	5600
Beta 165-SSS	4005 / 4010	18000	5000	15000	8000	700	1400	1100	3,00	0.1 / 0.04	0.03	8	5010	5600
Beta 165-SGV	4020 / 4040	18000	-	-	-	-	-	-	3,00	0.1 / 0.04	0.03	8	5020	5600
Beta 165-C-SGV	5010 / 5020	25000	-	-	-	-	-	-	3.2	0.1 / 0.04	0.03	6	5020	5600
Beta 165-C-SSF	5010 / 5020	25000	5000	15000	8000	800	1800	1400	3.2	0.1 / 0.04	0.03	6	5010	5600
Beta 180-SSS	3205 / 3210 3220 / 3240	12000	6000	12000	6000	1500	3000	1500	2.5	0.1 / 0.04	0.03	8	5030	5600
Beta 180-C-SSS	3260	12000	8000	15000	8000	1800	3600	1800	2.5	0.1 / 0.04	0.03	8	5030	5600
Delta 90-SRS	1205 / 1210	1000	500	1000	1000	60	80	80	0.8	0.08 / 0.03	0.03	2	1185	1500
Delta 110-C-SSS	1605 / 1610 1620 / 1640	2000	1200	3000	1500	500	550	550	1,00	0.08 / 0.03	0.03	8	5455	5600
Delta 145-C-SSS	2005 / 2010 2020 / 2050	4000	2500	5000	3000	800	1000	1000	1,00	0.08 / 0.03	0.03	8	5275	5600
Delta 200-SSS	3205 / 3210	10000	5000	8000	5000	3500	4300	3200	2.8	0.1 / 0.04	0.03	4	1620	2000
Delta 240-SSS	3220 / 3240	12000	6000	12000	8000	4500	6000	4500	2.8	0.1 / 0.04	0.03	4	2600	3000
Delta 240-C-SSS	3260	12000	6000	12000	8000	4500	6000	4500	2.8	0.1 / 0.04	0.03	4	5400	5600
Alpha 15-B-155	2005 / 2010 2020 / 2050	4000	2000	20000	15000	1000	900	400	0.35	0.08 / 0.03	0.03	-	1235	1500
Alpha 20-B-225	2505 / 2510 2525 / 2550	6000	5000	58000	40000	4000	3000	1200	1.2	0.1 / 0.04	0.03	-	1645	2000
Alpha 30-B-325	3205 / 3210 3220 / 3240	12000	11000	95000	63000	6300	7500	3750	1.6	0.1 / 0.04	0.03	-	2540	3000
Alpha 35-B-455	4005 / 4010 4020 / 4040	18000	14000	120000	80000	12000	10000	5000	2.5	0.1 / 0.04	0.03	-	2420	3000

For mechanical linear drives with roller guides, the static load rating (C_{stat} page TL11) applies for static loads.

- M_{idle} = Idle torque ±30 %
- d_{pn/ps} = Axial clearance (normal/low backlash)
- d_s = Repeat accuracy ±
- SA = Maximum number of spindle supports
- S_{max} = Maximum standard stroke length without spindle support (longer on request)
- L_{max} = Maximum standard length (longer on request)

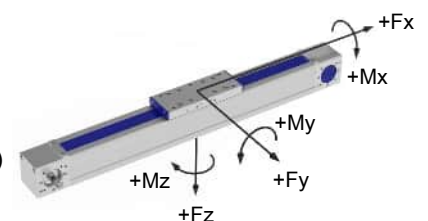

Performance Overview of Portal Linear Drives with Toothed Belt Drive or Rack-and-Pinion Drive

HSB-gamma®
HSB-sigma®

Description	Toothed belt/ Rack and pinion	F _x [N]	F _y [N]	F _z [N]	-F _z [N]	M _x [Nm]	M _y [Nm]	M _z [Nm]	M _{leer} [Nm]	d _s [mm]	S _{max} [mm]	L _{max} [mm]
Gamma 90-ZSS	32 AT10	2300	2500	3000	3000	500	1200	1000	3.2	0.08	7650	8100
Gamma 90-ZSSD	2 x 16 AT10	1150	2500	3000	3000	500	800	700	2.9	0.08	7560	8100
Gamma 90-ASH	32 AT10-E	2300	2500	3000	3000	500	2300	1900	3.2	0.08	7560	8000
Gamma 90-AZ..	M2	1300 - 1800	3000	3000	3000	600	1800	1800	2.5	0.05	7600	8000
Gamma 120-ZSS	40 AT10-E	2800	6000	8000	8000	1200	3000	2500	3.00	0.08	7685	8200
Gamma 120-ZSSD	2 x 25 ATL10	1800	6000	8000	8000	1200	1300	1100	3.00	0.08	7638	8200
Gamma 120-ASH	40 AT10-E	3200	6000	8000	8000	1200	5000	4200	3.6	0.08	7450	8000
Gamma 120-AZ..	M 2	1500 - 2200	8000	8000	8000	1500	4000	4000	4.8	0.05	7470	8000
Gamma 160-ZSS	50 ATL10	4000	10000	16000	16000	1800	5000	4000	4.00	0.08	7580	8200
Gamma 160-ZSSD	2 x 32 AT10	2200	10000	16000	16000	1800	5000	4000	4.00	0.08	7250	8200
Gamma 160-ASH	50 AT10-E	4000	10000	16000	16000	1800	8000	7000	4.00	0.08	7350	8000
Gamma 160-AZ..	M 2	1500 - 4000	12000	12000	12000	2500	7000	7000	5.8	0.05	7370	8000
Gamma 220-ZSS	75 ATL10	6000	12000	20000	20000	2500	8000	6500	7.00	0.08	7580	8260
Gamma 220-ZSSD	2 x 40 AT10	2800	12000	20000	20000	2500	8000	6500	5.25	0.08	7220	8220
Gamma 220-ASS	75 AT10-E	6000	12000	20000	20000	2500	12000	10000	7.00	0.08	7400	8020
Gamma 220-AZ..	M 2	3000 - 6000	20000	20000	20000	4000	8000	8000	7.2	0.05	7340	8020
Gamma 220-AZ..	M 3	3000 - 7500	20000	20000	20000	4000	8000	8000	7.2	0.05	7340	8020
Gamma 280-ZSS	75 ATS15	10000	20000	30000	30000	4000	15000	12000	11.00	0.08	7450	8370
Gamma 280-ZSSD	2 x 50 ATL10	4000	20000	30000	30000	4000	15000	12000	11.00	0.08	7010	8270
Gamma 280-AZ..	M 3	3000 - 7500	25000	25000	25000	8000	16000	16000	8.6	0.05	7250	8030
Sigma 70-ZRS	25 AT5-E	1050	1350	1850	1200	50	70	80	0.85	0.08	7805	8100
Sigma 70-ARH	25 AT5-E	1050	1350	1850	1200	50	120	110	0.85	0.08	7700	8000
Sigma 70-ARS	25 AT5-E	1050	1350	1850	1200	50	70	80	0.85	0.08	7775	8000
Sigma 90-ZRS	32 AT5-E	1300	2000	2500	1500	120	160	150	3.2	0.08	7760	8100
Sigma 90-ZRSD	2 x 16 AT5-E	650	2000	2500	1500	120	160	150	3.2	0.08	7595	8100
Sigma 90-ARH	32 AT5-E	1300	2000	2500	1500	120	230	200	2.3	0.08	7745	8000
Sigma 90-ARS	32 AT5-E	1300	2000	2500	1500	120	160	150	2.3	0.08	7740	8000
Sigma 120-ZRS	40 AT10-E	2800	2300	3000	1800	170	270	270	3.00	0.08	7660	8100
Sigma 120-ZRSD	2 x 25 ATL10	1800	2300	3000	1800	170	270	270	3.00	0.08	7420	8100
Sigma 120-ARH	40 AT10-E	3200	2300	3000	1800	170	400	400	3.8	0.08	7510	8000
Sigma 120-ARS	40 AT10-E	3200	2300	3000	1800	170	270	270	3.8	0.08	7600	8000
Sigma 160-ZRS	50 ATL10	4000	4500	6000	4000	500	700	700	4.00	0.08	5570	6100
Sigma 160-ZRSD	2 x 32 AT10	2300	4500	6000	4000	500	700	700	3.5	0.08	5300	6100
Sigma 160-ARH	50 AT10-E	4000	4500	6000	4000	500	1000	1000	4.2	0.08	5430	6000
Sigma 160-ARS	50 AT10-E	4000	4500	6000	4000	500	700	700	4.2	0.08	5580	6000

- M_{idle} = Idle torque ±30 %
d_s = Repeat accuracy ±
S_{max} = Maximum standard stroke length (longer on request)
L_{max} = Maximum standard length (longer on request)

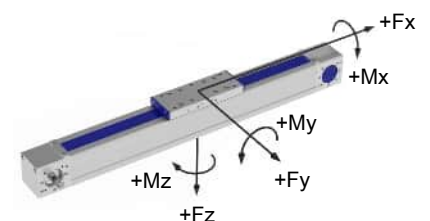

Chapter B

Mechanical Linear Drive

HSB-beta®

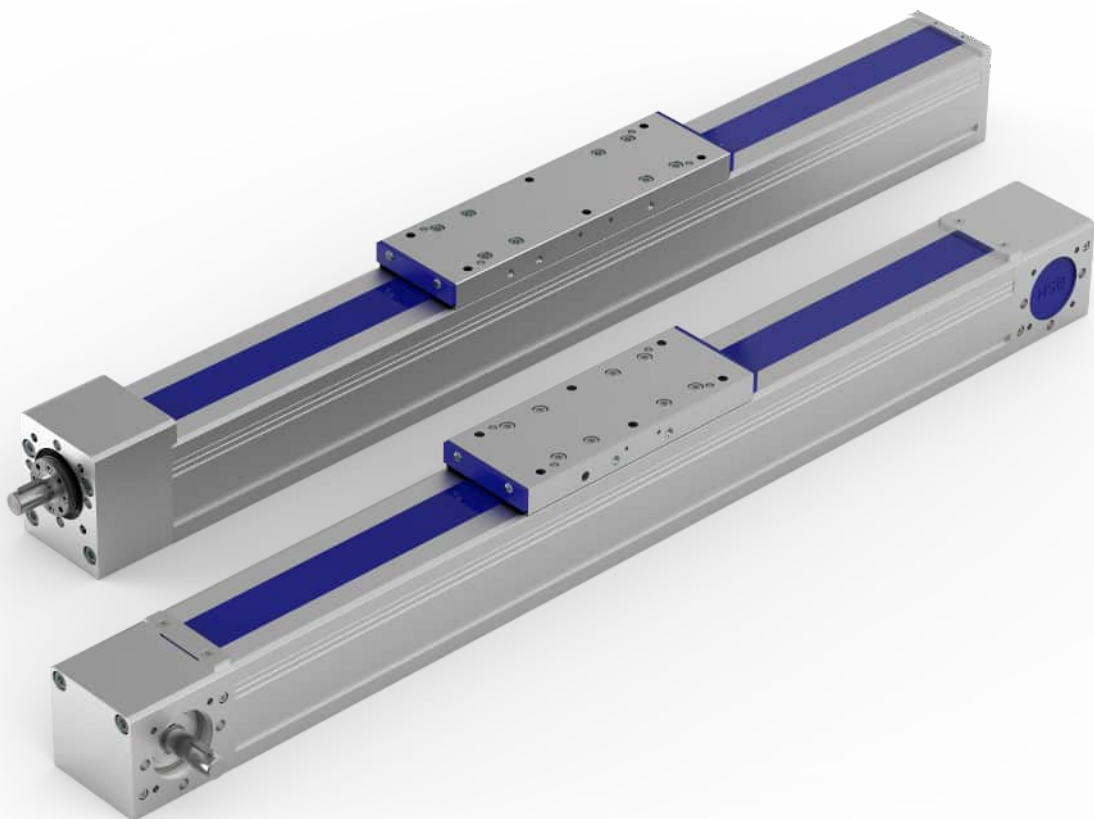

with toothed belt drive and sliding guide (ZGS) or rail guide (ZSS)

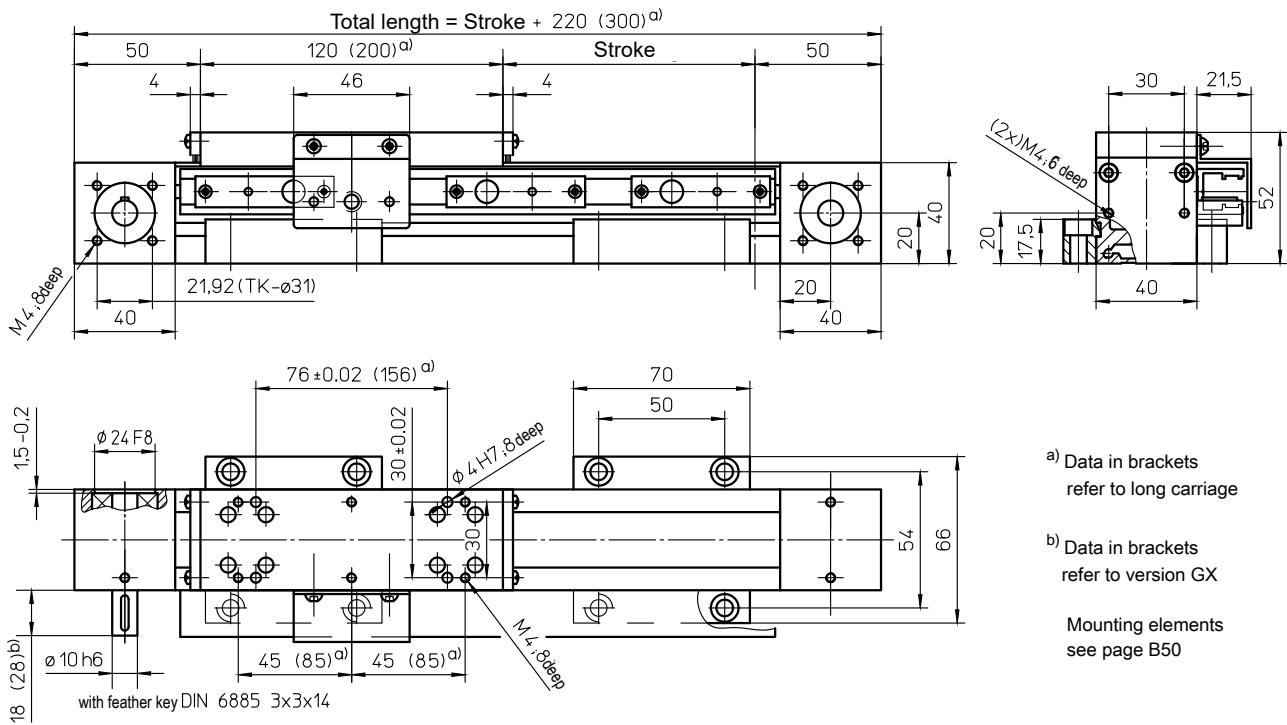

Weights	ZGS	ZSS
Basic length without stroke:	1.50 kg	1.70 kg
100 mm stroke:	0.20 kg	0.30 kg
Entire carriage 120 mm:	0.30 kg	
Entire carriage 200 mm:	0.50 kg	
Max. total length:	3000 mm	2070 mm

Technical Data	ZGS	ZSS
Max. speed:	1.00 m/s	3.00 m/s
Max. acceleration:	20 m/s ²	30 m/s ²
Repeat accuracy:	± 0.08 mm	
Idle torque:	0.30 Nm	
Moment of inertia:	2.00 · 10 ⁻⁴ kgm ²	
Drive element:	Toothed belt 16 AT5-E	
Stroke per revolution:	100 mm	

Forces and moments

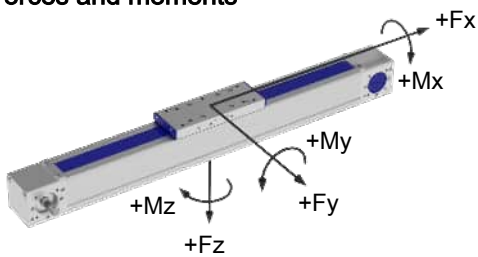

	ZGS	ZSS
Forces	Dynamic [N]	
F _x ^{d)}	500	
F _y	80	500
F _z	150	600
-F _z	75	300
Moments	Dynamic [Nm]	
M _x	6	12
M _y	6	30 (50)
M _z	8	30 (50)

^{d)} Maximum value (see diagram "F_x-v-Diagram")
Data in brackets refer to long carriage (200)

F_x - v - Diagram

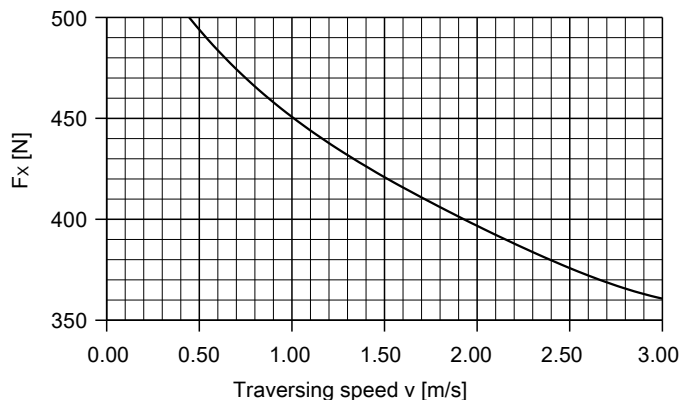

>> Note << Drive shaft is not changeable
Please define position, e.g. "AZ1"! (See Ordering Code)

with ball screw (KGT) and sliding guide (SGS) or rail guide (SSS)

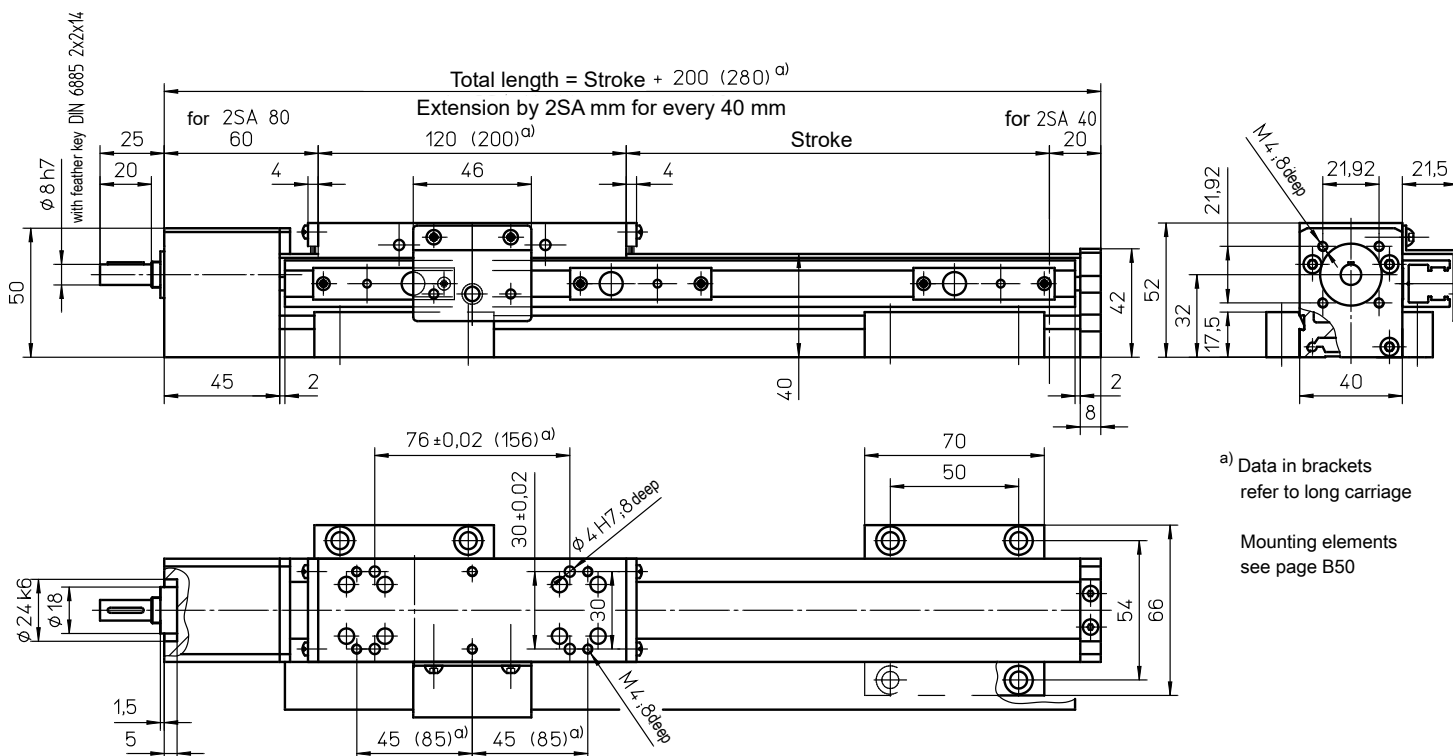

Weights	SGS	SSS
Basic length without stroke:	1.50 kg	1.70 kg
100 mm stroke:	0.30 kg	0.40 kg
Entire carriage 120 mm:	0.30 kg	0.40 kg
Entire carriage 200 mm:	0.50 kg	0.65 kg

Technical Data	SGS	SSS
Max. speed:	0.5 m/s	
Max. acceleration:	20 m/s ²	
Repeat accuracy:	± 0.03 mm (KGT)	
Idle torque:	0.30 Nm	0.4 Nm

Max. total length: 2040 mm

Forces and moments

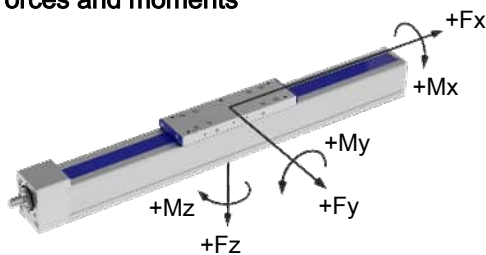

Drive element KGT

Max. rotation speed:	3000 min ⁻¹
Diameter:	12 mm
Pitch:	5 / 10 mm
Moment of inertia:	1.13 · 10 ⁻⁵ kgm ² /m

Spindle support (SA) (only available with SSS)

	SGS	SSS
Forces	Dynamic [N]	
F_x	1000	
F_y	80	500
F_z	150	600
-F_z	75	300
Moments	Dynamic [Nm]	
M_x	6	12
M_y	6	30 (50)
M_z	8	30 (50)

Data in brackets refer to long carriage (200)

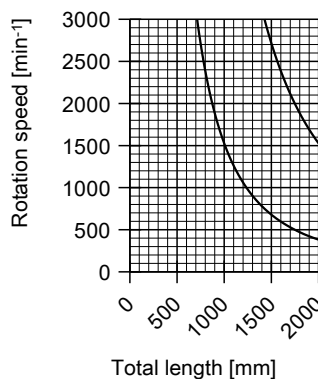

Special design: Spindle support with damping ring (extension of total length: 10 mm for every 2 SA)
Version with double nut not possible.

with toothed belt drive and roller guide (ZRS)

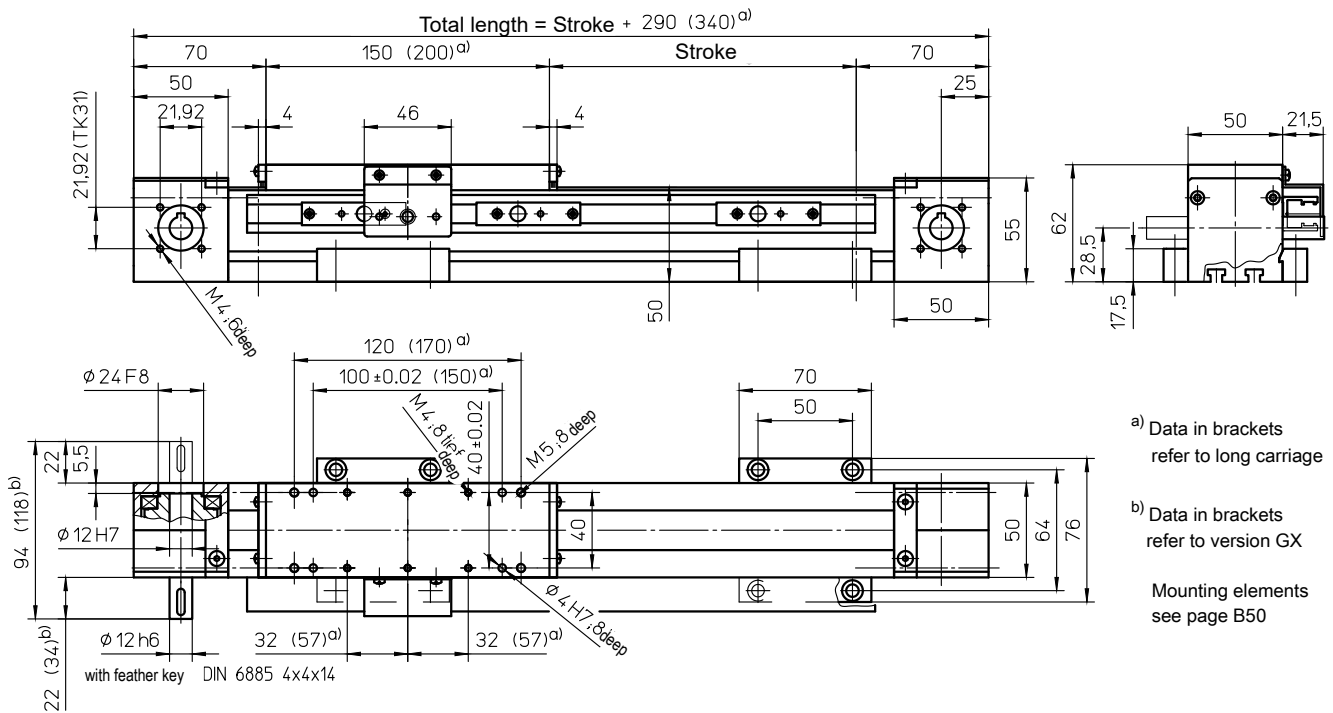

a) Data in brackets refer to long carriage
 b) Data in brackets refer to version GX
 Mounting elements see page B50

Weights ZRS

Basic length without stroke:	1.45 kg
100 mm stroke:	0.35 kg
Entire carriage 150 mm:	0.45 kg
Entire carriage 200 mm:	0.60 kg
Max. total length: (longer on request)	8000 mm

Technical Data ZRS

Max. total speed:	3.00 m/s
Max. acceleration:	30 m/s ²
Repeat accuracy:	± 0.08 mm
Idle torque:	0.40 Nm
Moment of inertia:	3.00 · 10 ⁻⁴ kgm ²
Drive element:	Toothed belt 20 AT5-E
Stroke per revolution:	110 mm

Forces and moments

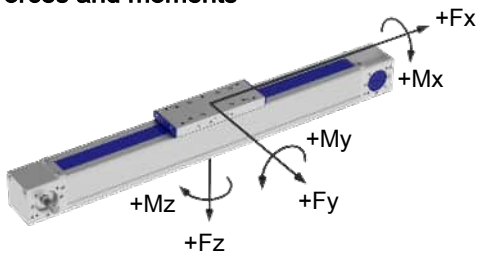

ZRS	
Forces	Dynamic [N]
F_x^{d)}	700
F_y	300
F_z	600
-F_z	400
Moments	Dynamic [Nm]
M_x	30
M_y	50 (65)
M_z	50 (65)

^{d)} Maximum value (see diagram "F_x-v-Diagram")
 Data in brackets refer to long carriage (200)

F_x - v - Diagram

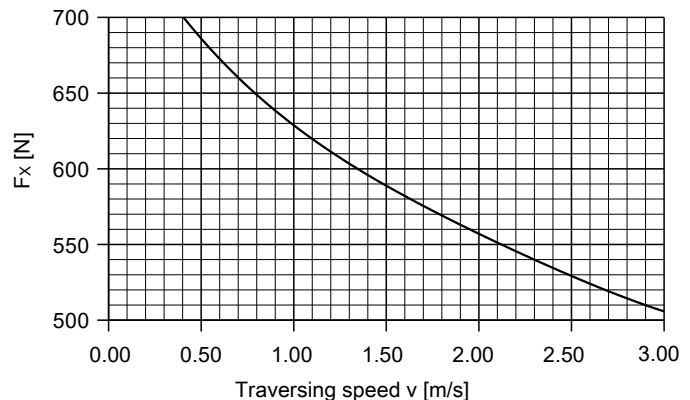

For mechanical linear drives with roller guide, the static load rating "C_{stat}" (page TL11) applies for static loads.

with toothed belt drive and roller guide (ARS)

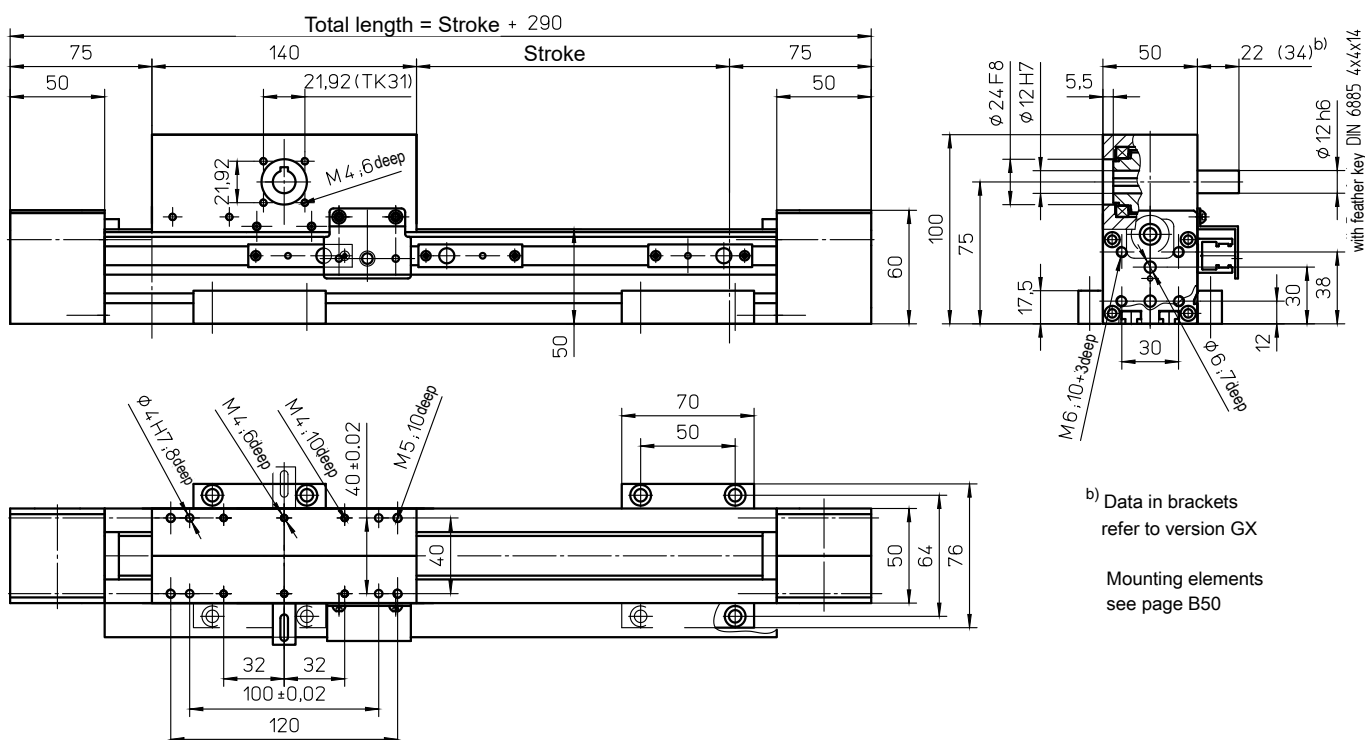

Weights	ARS
Basic length without stroke:	3.10 kg
100 mm stroke:	0.30 kg
Carriage drive 140 mm:	1.30 kg
Max. total length: (longer on request)	8000 mm

Technical Data	ARS
Max. speed:	3.00 m/s
Max. acceleration:	30 m/s ²
Repeat accuracy:	± 0.08 mm
Idle torque:	1.50 Nm
Moment of inertia:	3.00 · 10 ⁻⁴ kgm ²
Drive element:	Toothed belt 20 AT5-E
Stroke per revolution:	110 mm

Forces and moments

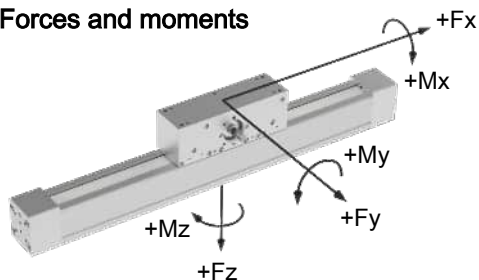

ARS	
Forces	Dynamic [N]
F_x^{d)}	700
F_y	300
F_z	600
-F_z	400
Moments	Dynamic [Nm]
M_x	30
M_y	50
M_z	50

^{d)} Maximum value (see diagram "F_x-v-Diagram")

F_x - v - Diagram

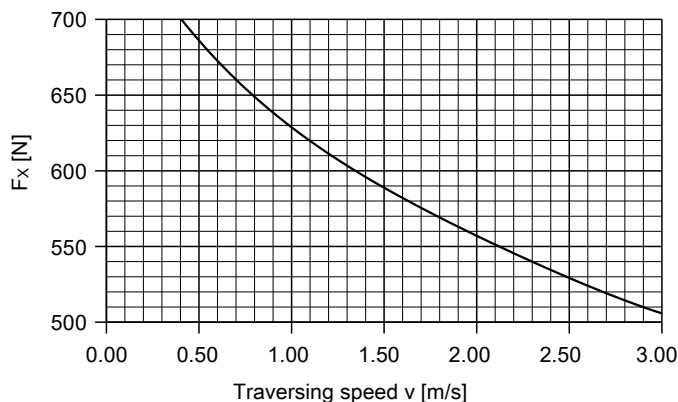

For mechanical linear drives with roller guide, the static load rating "C_{stat}" (page TL 11) applies for static loads.

with ball screw (KGT) and roller guide (SRS)

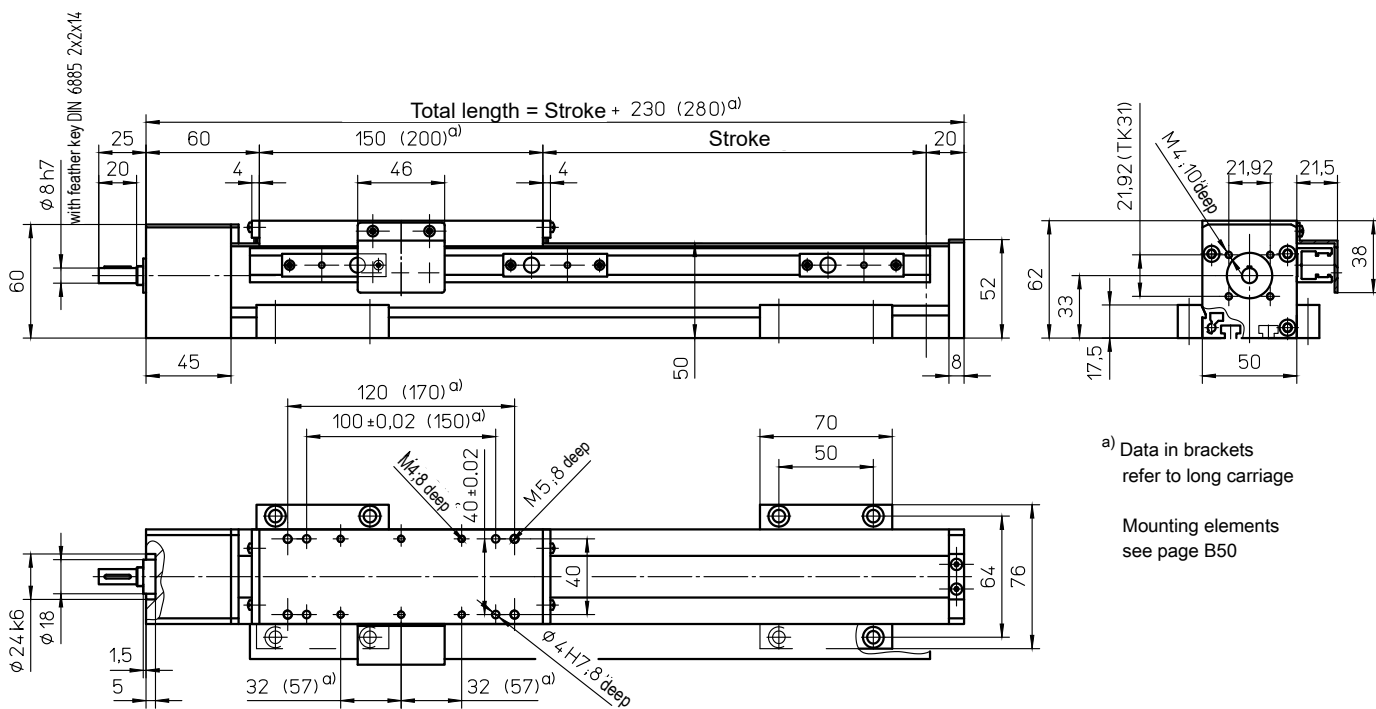

a) Data in brackets refer to long carriage
Mounting elements see page B50

Weights SRS

Basic length without stroke:	1.50 kg
100 mm stroke:	0.40 kg
Entire carriage 150 mm:	0.45 kg
Entire carriage 200 mm:	0.60 kg

Max. total length: 1090 mm

Technical Data SRS

Max. speed:	0.5 m/s
Max. acceleration:	20 m/s ²
Repeat accuracy:	± 0.03 mm (KGT)
Idle torque:	0.30 Nm

Forces and moments

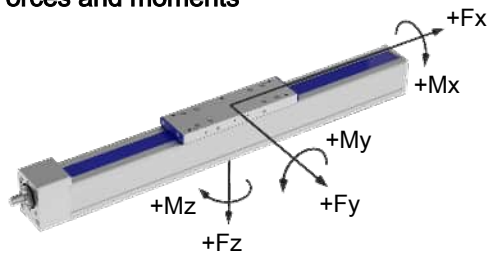

SRS	
Forces	Dynamic [N]
F_x	1000
F_y	300
F_z	600
-F_z	400
Moments	Dynamic [Nm]
M_x	30
M_y	50 (65)
M_z	50 (65)

Data in brackets refer to long carriage (200)

Drive element KGT

Max. rotation speed:	3000 min ⁻¹
Diameter:	12 mm
Pitch:	5 / 10 mm
Moment of inertia:	1.13 • 10 ⁻⁵ kgm ² /m

Max. rotation speed

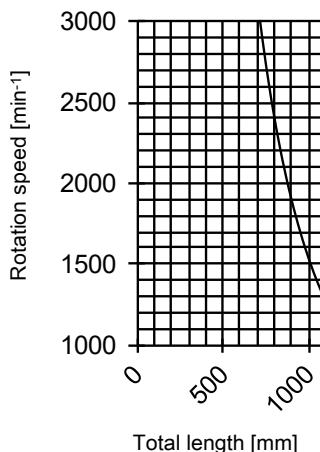

For mechanical linear drives with roller guide, the static load rating "C_{stat}" (page TL 11) applies for static loads. Version with double nut not possible.

with toothed belt drive and rail guide (ZSS)

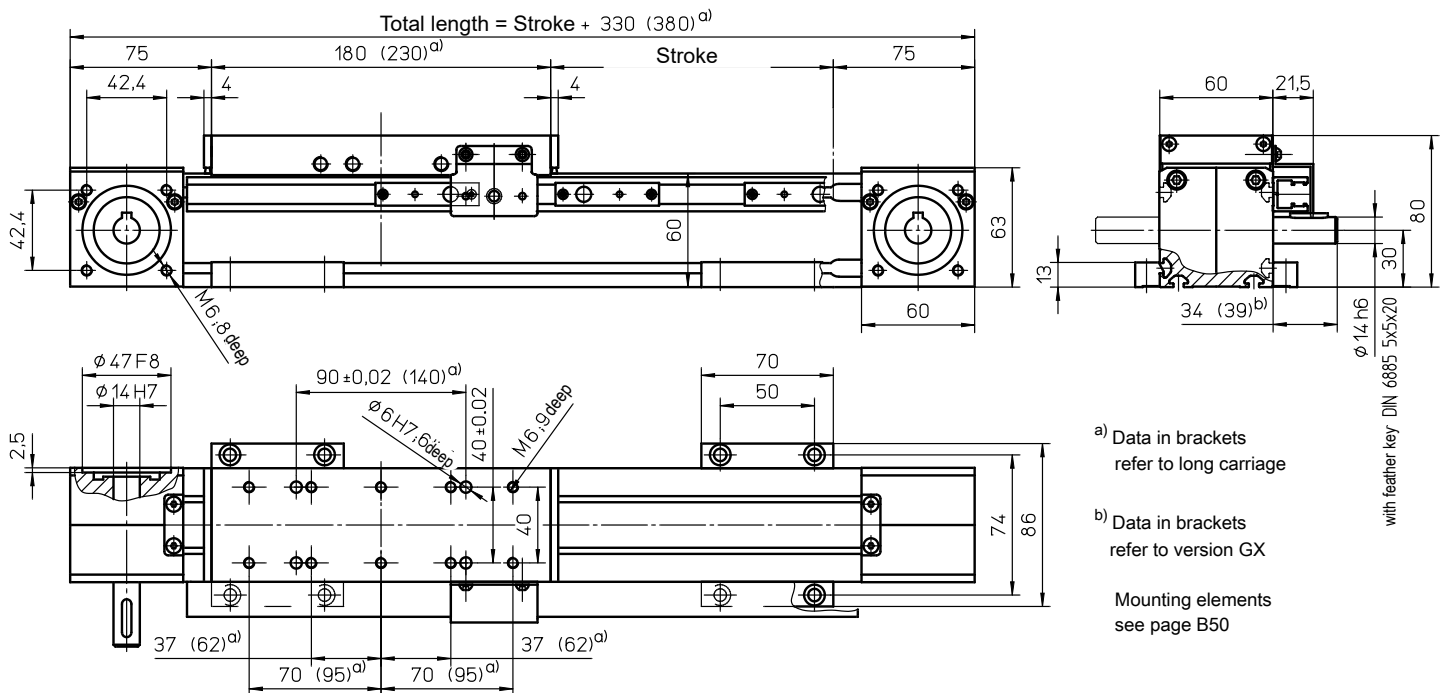

Weights

ZSS

Basic length without stroke:	4.55 kg
100 mm stroke:	0.59 kg
Entire carriage 180 mm:	1.22 kg
Entire carriage 230 mm:	1.72 kg
Max. total length: (longer on request)	8000 mm

Technical Data

ZSS

Max. speed:	5.00 m/s
Max. acceleration:	30 m/s ²
Repeat accuracy:	± 0.08 mm
Idle torque:	1.10 Nm
Moment of inertia:	$2.00 \cdot 10^{-4}$ kgm ²
Drive element:	Toothed belt 25 AT5-E
Stroke per revolution:	160 mm

Forces and moments

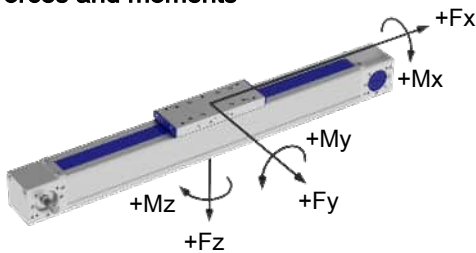

ZSS	
Forces	Dynamic [N]
F_x ^{d)}	850
F_y	500
F_z	1400
$-F_z$	800
Moments	Dynamic [Nm]
M_x	50
M_y	160 (200)
M_z	100 (140)

^{d)} Maximum value (see diagram "F_x-v-Diagram")
 Data in brackets refer to long carriage (230)

F_x - v - Diagram

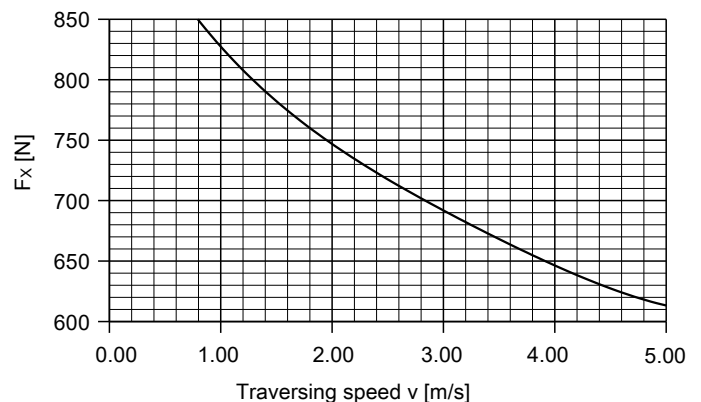

with ball screw (KGT) and sliding guide (SGV) or rail guide (SSS)

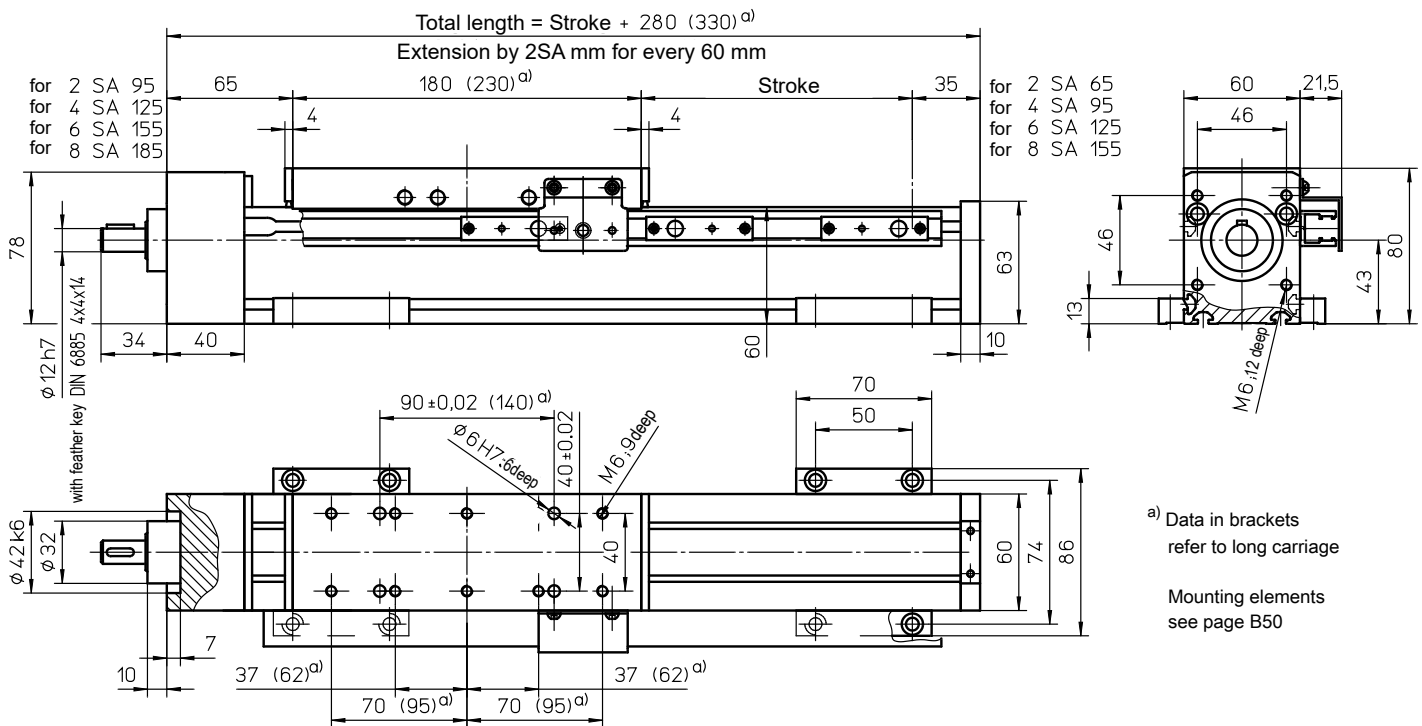

Weights	SGV	SSS
Basic length without stroke:	3.65 kg	4.30 kg
100 mm stroke:	0.65 kg	0.80 kg
Entire carriage 180 mm:	1.15 kg	1.50 kg
Entire carriage 230 mm:	-	1.80 kg

Max. total length: 5500 mm
(longer on request)

Forces and moments

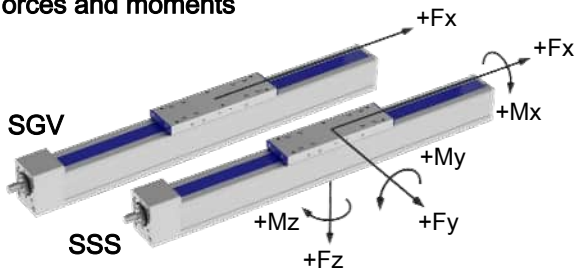

	SGV	SSS
Forces	Dynamic [N]	
F_x	4000	
F_y	-	600
F_z	-	1800
-F_z	-	1200
Moments	Dynamic [Nm]	
M_x	-	60
M_y	-	180 (220)
M_z	-	120 (150)

"-" => Must have an external guide.
Data in brackets refer to long carriage (230)

Technical Data	SGV	SSS
Max. speed:	2.50 m/s	
Max. acceleration:	20 m/s ²	
Repeat accuracy:	± 0.03 mm (KGT)	
Idle torque:	0.70 Nm	

Drive element	KGT
Max. rotation speed:	3000 min ⁻¹
Diameter:	20 mm
Pitch:	5 / 10 / 20 / 50 mm
Moment of inertia:	8.40 • 10 ⁻⁵ kgm ² /m

Spindle support (SA)

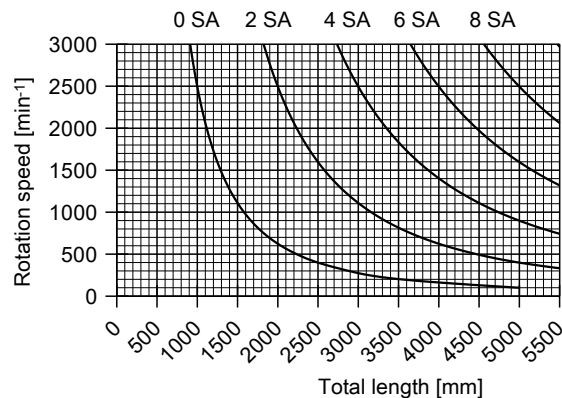

Special design: Spindle support with damping ring (extension of total length: 10 mm for every 2 SA)
Design with double nut („MM“) is only available with carriage plate 230 mm and pitch „5“, „10“ oder „20“.
Design with single nut („M“) and pitch „50“ is only available with carriage plate 230 mm.

with toothed belt drive and roller guide (ZRS) or rail guide (ZSS)

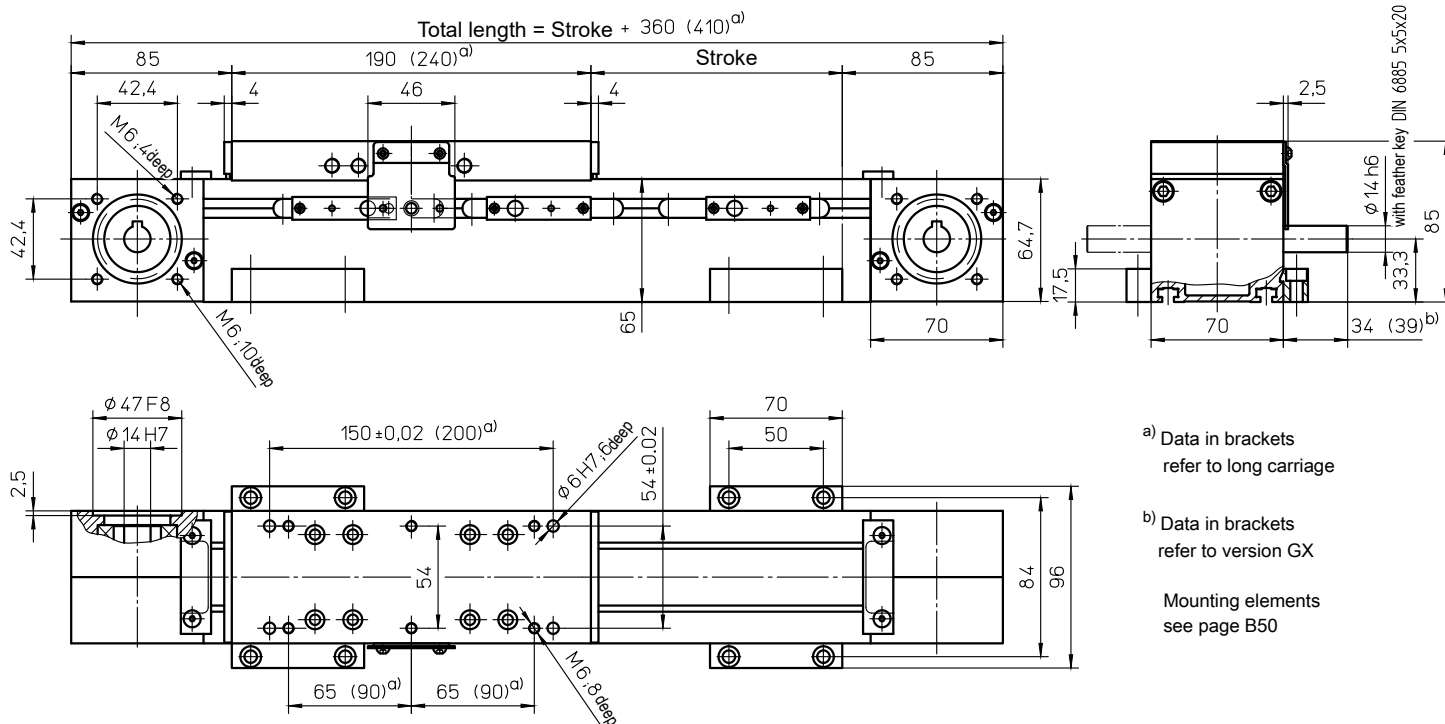

a) Data in brackets refer to long carriage

b) Data in brackets refer to version GX

Mounting elements see page B50

Weights	ZRS	ZSS
Basic length without stroke:	3.10 kg	3.40 kg
100 mm stroke:	0.45 kg	0.60 kg
Entire carriage 190 mm:	1.30 kg	1.65 kg
Entire carriage 240 mm:	1.65 kg	2.10 kg
Max. total length: (longer on request)	8000 mm	7200 mm

Technical Data	ZRS	ZSS
Max. speed:	8.00 m/s	5.00 m/s
Max. acceleration:	30 m/s ²	
Repeat accuracy:	± 0.08 mm	
Idle torque:	1.20 Nm	
Moment of inertia:	4.00 · 10 ⁻⁴ kgm ²	2.00 · 10 ⁻⁴ kgm ²
Drive element:	Toothed belt 32 AT5-E	
Stroke per revolution:	175 mm	

Forces and moments

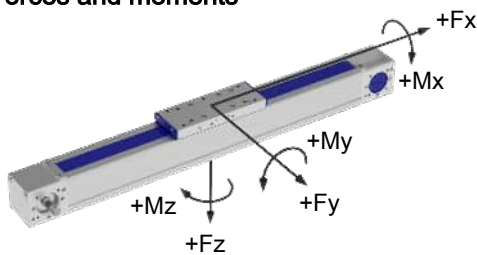

	ZRS	ZSS
Forces	Dynamic [N]	
F_x^{d)}	1100	
F_y	300	600
F_z	1000	1800
-F_z	400	1200
Moments	Dynamic [Nm]	
M_x	35	60
M_y	120 (150)	180 (230)
M_z	50 (60)	120 (150)

^{d)} Maximum value (see diagram "F_x-v-Diagram")
Data in brackets refer to long carriage plate (240)

F_x - v - Diagram

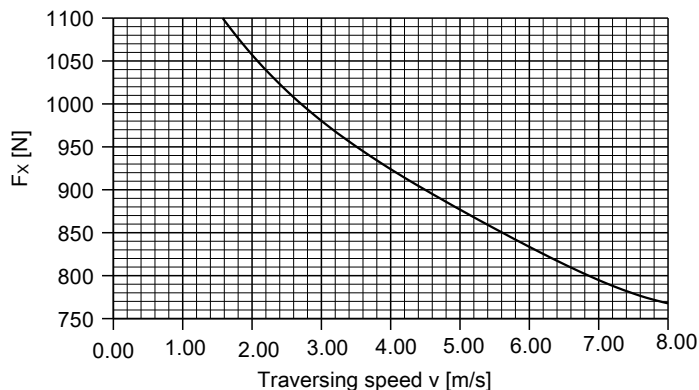

For mechanical linear drives with roller guide, the static load rating "C_{stat}" (page TL 11) applies for static loads.

with toothed belt drive and roller guide (ARS) or rail guide (ASS)

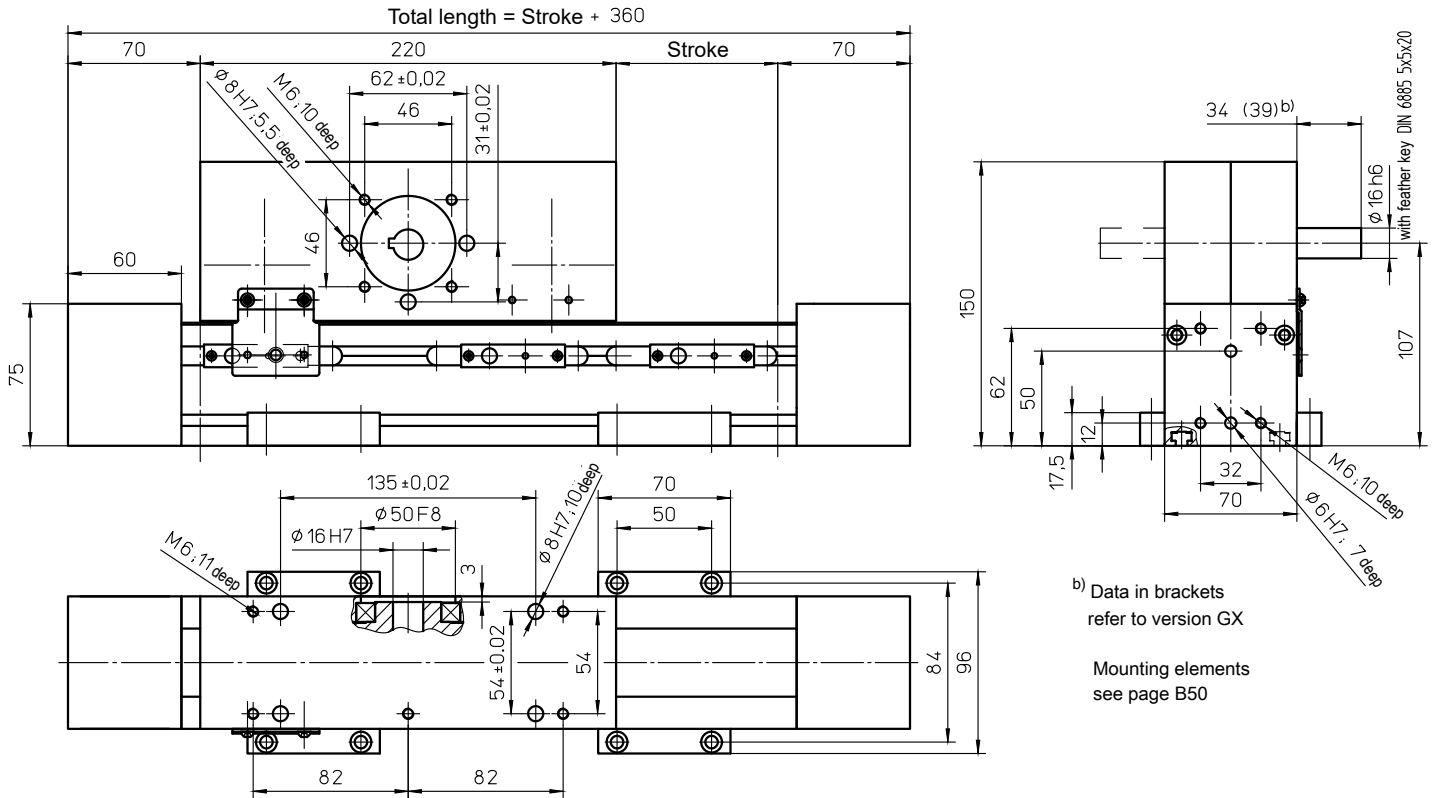

Weights	ARS	ASS
Basic length without stroke:	7.50 kg	7.90 kg
100 mm stroke:	0.44 kg	0.59 kg
Carriage drive 220 mm:	5.00 kg	5.50 kg
Max. total length: (longer on request)	8000 mm	

Technical Data	ARS	ASS
Max. speed:	5.00 m/s	
Max. acceleration:	30 m/s ²	
Repeat accuracy:	± 0.08 mm	
Idle torque:	1.00 Nm	
Moment of inertia:	6.10 · 10 ⁻³ kgm ²	
Drive element:	Toothed belt 32 AT5-E	
Stroke per revolution:	220 mm	

Forces and moments

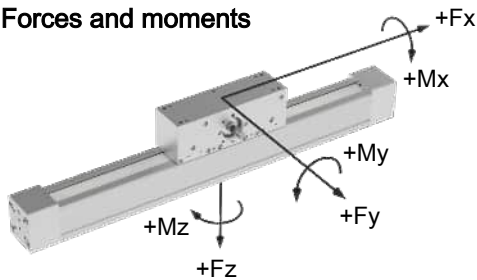

	ARS	ASS
Forces	Dynamic [N]	
F_x^{d)}	900	
F_y	300	600
F_z	1000	1800
-F_z	400	1200
Moments	Dynamic [Nm]	
M_x	35	60
M_y	120	180
M_z	50	120

^{d)} Maximum value (see diagram "F_x-v-Diagram")

F_x - v - Diagram

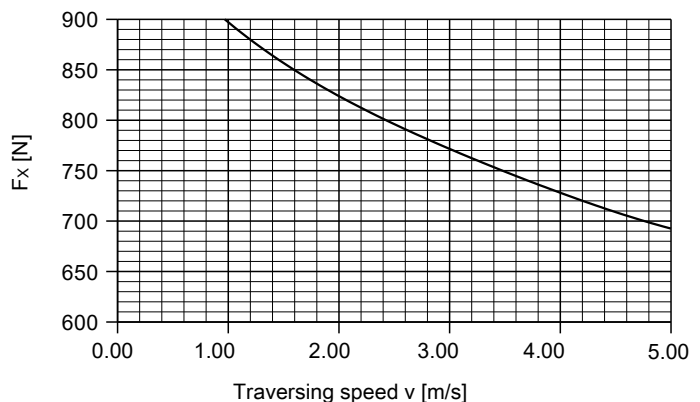

For mechanical linear drives with roller guide, the static load rating "C_{stat}" (page TL 11) applies for static loads.

with ball screw (KGT) and roller guide (SRS) or rail guide (SSS)

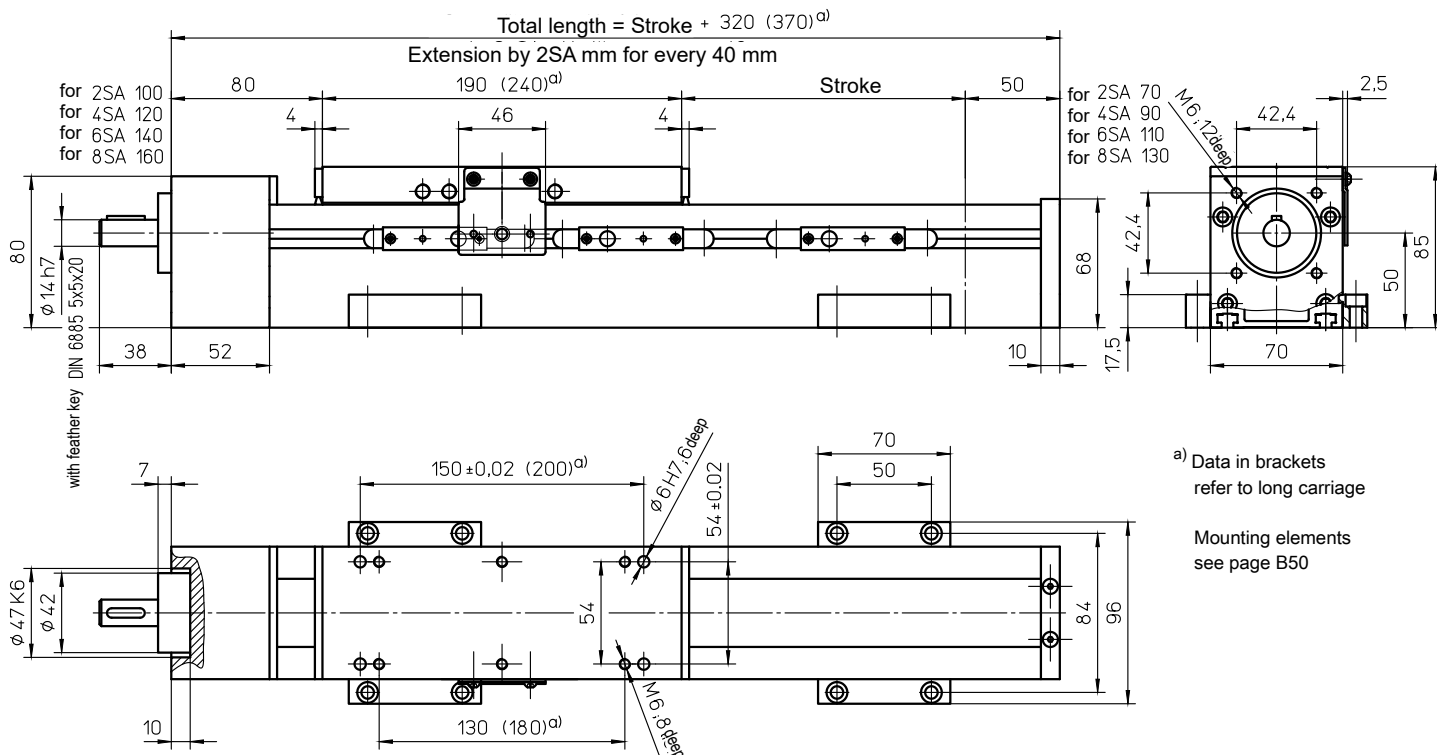

Weights	SRS	SSS
Basic length without stroke:	3.65 kg	3.50 kg
100 mm stroke:	0.56 kg	0.71 kg
Entire carriage 190 mm:	1.60 kg	1.25 kg
Entire carriage 240 mm:	2.02 kg	1.60 kg

Max. total length: 4000 mm
(longer on request)

Technical Data	SRS	SSS
Max. speed:	2.00 m/s	
Max. acceleration:	20 m/s ²	
Repeat accuracy:	± 0.03 mm (KGT)	
Idle torque:	0.35 Nm	0.40 Nm

Forces and moments

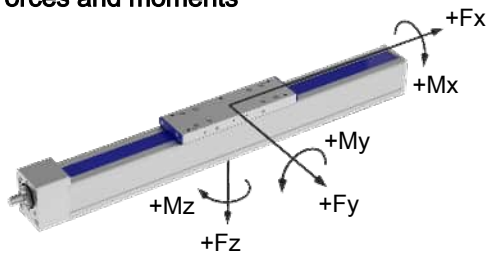

	SRS	SSS
Forces	Dynamic [N]	
F_x	2000	
F_y	300	600
F_z	1000	1800
-F_z	400	1200
Moments	Dynamic [Nm]	
M_x	35	60
M_y	120 (150)	180 (220)
M_z	60 (70)	120 (150)

Data in brackets refer to long carriage plate (240)

Drive element

KGT

Max. rotation speed:	3000 min ⁻¹
Diameter:	16 mm
Pitch:	5 / 10 / 20 / 40 mm
Moment of inertia:	3.32 · 10 ⁻⁵ kgm ² /m

Spindle support (SA)

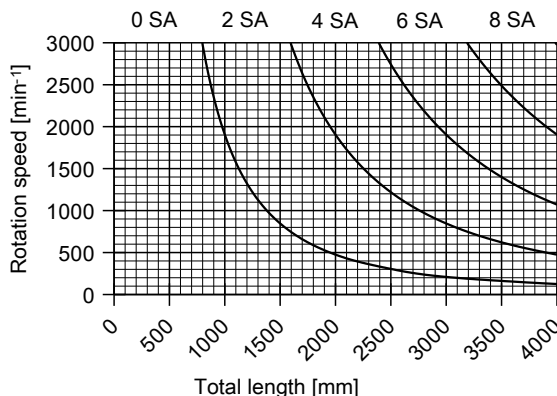

For mechanical linear drives with roller guide, the static load rating "C_{stat}" (page TL 11) applies for static loads.

Special design: Spindle support with damping ring (extension of total length: 10 mm for every 2 SA)

with toothed belt drive and roller guide (ZRS) or rail guide (ZSS)

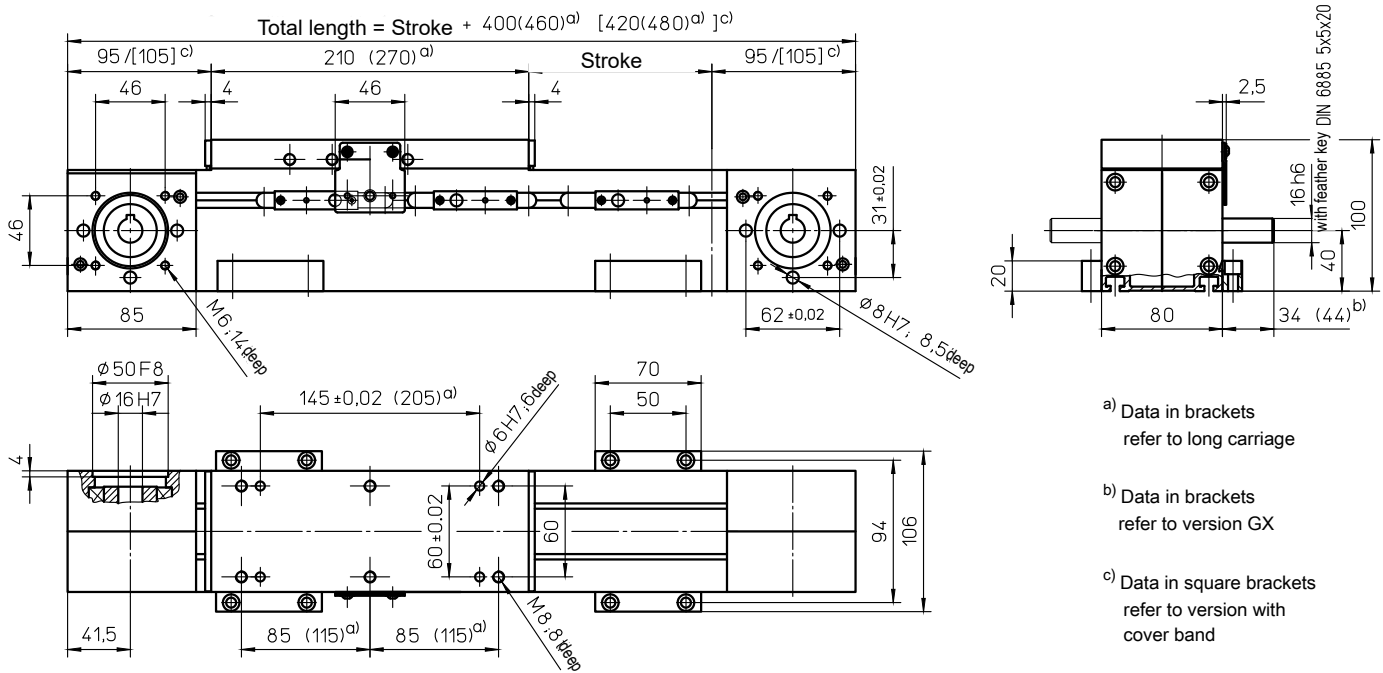

- a) Data in brackets refer to long carriage
- b) Data in brackets refer to version GX
- c) Data in square brackets refer to version with cover band

Mounting elements see page B50

Weights	ZRS	ZSS
Basic length without stroke:	5.50 kg	6.10 kg
100 mm stroke:	0.60 kg	0.85 kg
Entire carriage 210 mm:	2.10 kg	1.80 kg
Entire carriage 270 mm:	2.70 kg	2.30 kg

Max. total length: 8000 mm
(longer on request)

Technical Data	ZRS	ZSS
Max. speed:	8.00 m/s	5.00 m/s
Max. acceleration:	40 m/s ²	
Repeat accuracy:	± 0.08 mm	
Idle torque:	1.50 Nm	
Moment of inertia:	3.30 · 10 ⁻³ kgm ²	3.00 · 10 ⁻³ kgm ²
Drive element:	Toothed belt 32 AT5-E	
Stroke per revolution:	220 mm	

Forces and moments

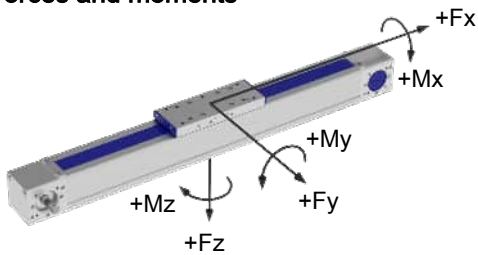

F_x - v - Diagram

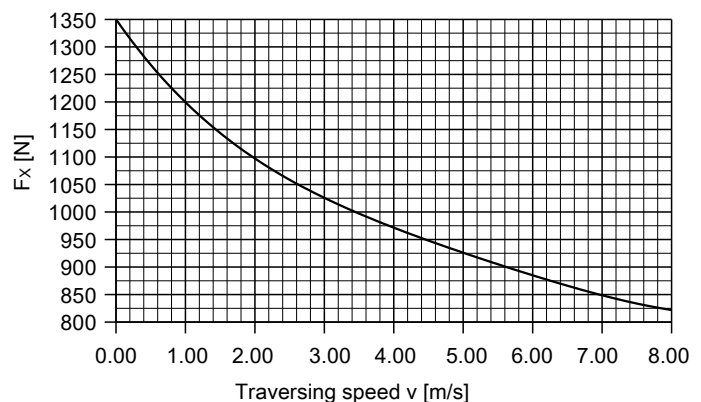

	ZRS	ZSS
Forces	Dynamic [N]	
F _x ^{d)}	1350	
F _y	500	800
F _z	1500	3000
-F _z	800	2000
Moments	Dynamic [Nm]	
M _x	50	100
M _y	180 (220)	250 (300)
M _z	100 (130)	250 (300)

^{d)} Maximum value (see diagram "F_x-v-Diagram")
Data in brackets refer to long carriage plate (270)

For mechanical linear drives with roller guide, the static load rating "C_{stat}" (page TL11) applies for static loads.

with ball screw (KGT) and roller guide (SRS) or rail guide (SSS)

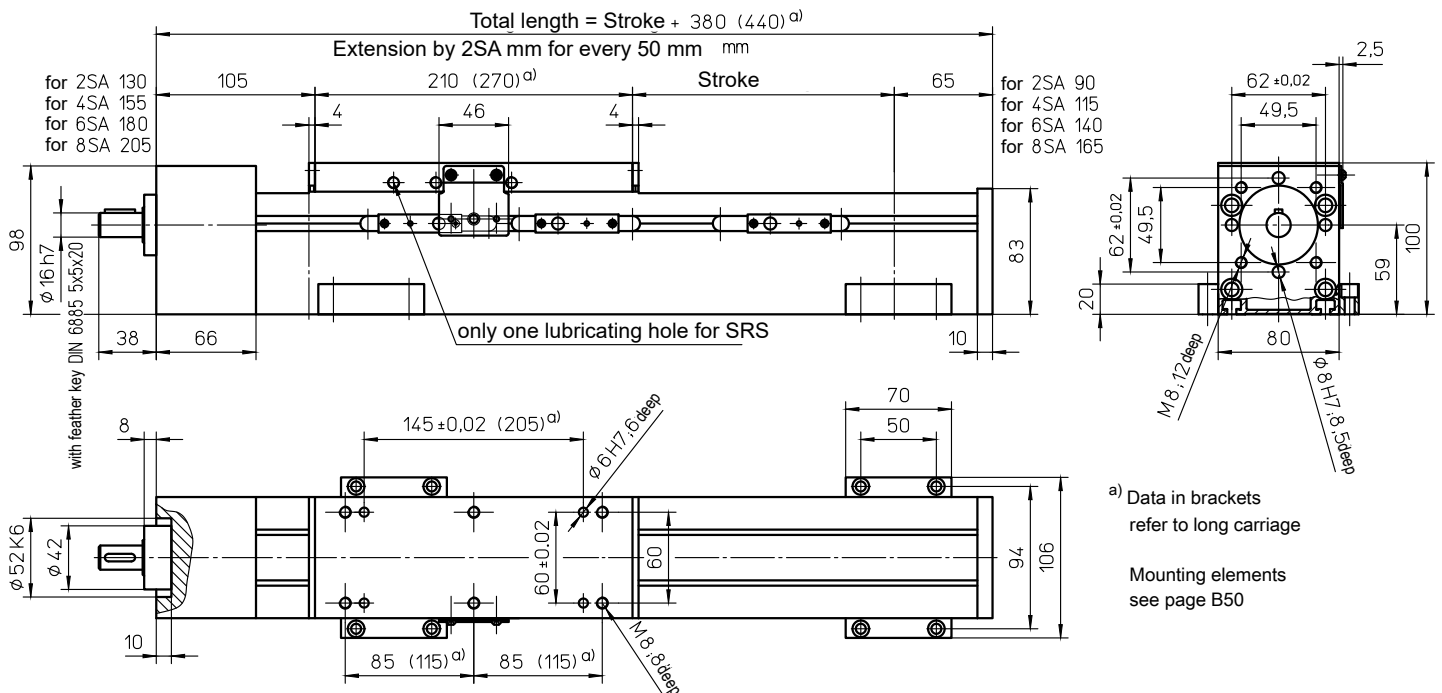

Weights	SRS	SSS
Basic length without stroke:	5.40 kg	6.20 kg
100 mm stroke:	0.70 kg	1.10 kg
Entire carriage 210 mm:	2.20 kg	1.90 kg
Entire carriage 270 mm:	2.80 kg	2.40 kg

Technical Data	SRS	SSS
Max. speed:	2.50 m/s	
Max. acceleration:	20 m/s ²	
Repeat accuracy:	± 0.03 mm (KGT)	
Idle torque:	0.60 Nm	0.80 Nm

Max. total length: 5600 mm
 (longer on request)

Forces and moments

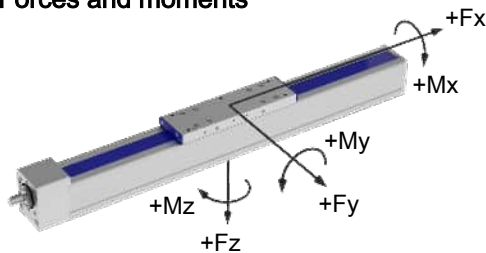

	SRS	SSS
Forces	Dynamic [N]	
F_x	4000	
F_y	500	800
F_z	1500	3000
-F_z	800	2000
Moments	Dynamic [Nm]	
M_x	50	100
M_y	180 (270)	250 (300)
M_z	100 (130)	250 (300)

Data in brackets refer to long carriage plate (270)

Drive element KGT

Max. rotation speed:	3000 min ⁻¹
Diameter:	20 mm
Pitch:	5 / 10 / 20 / 50 mm
Moment of inertia:	$8.40 \cdot 10^{-5}$ kgm ² /m

Spindle support (SA)

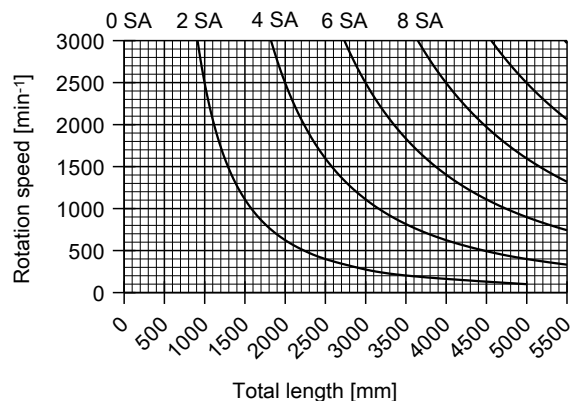

For mechanical linear drives with roller guide, the static load rating "C_{stat}" (page TL 11) applies for static loads.
 Special design: Spindle support with damping ring (extension of total length: 10 mm for every 2 SA)
 Design with double nut („MM“) is only available with long carriage plate 270 mm and pitch „5“, „10“ oder „20“.

with ball screw (KGT) and sliding guide (SGV)

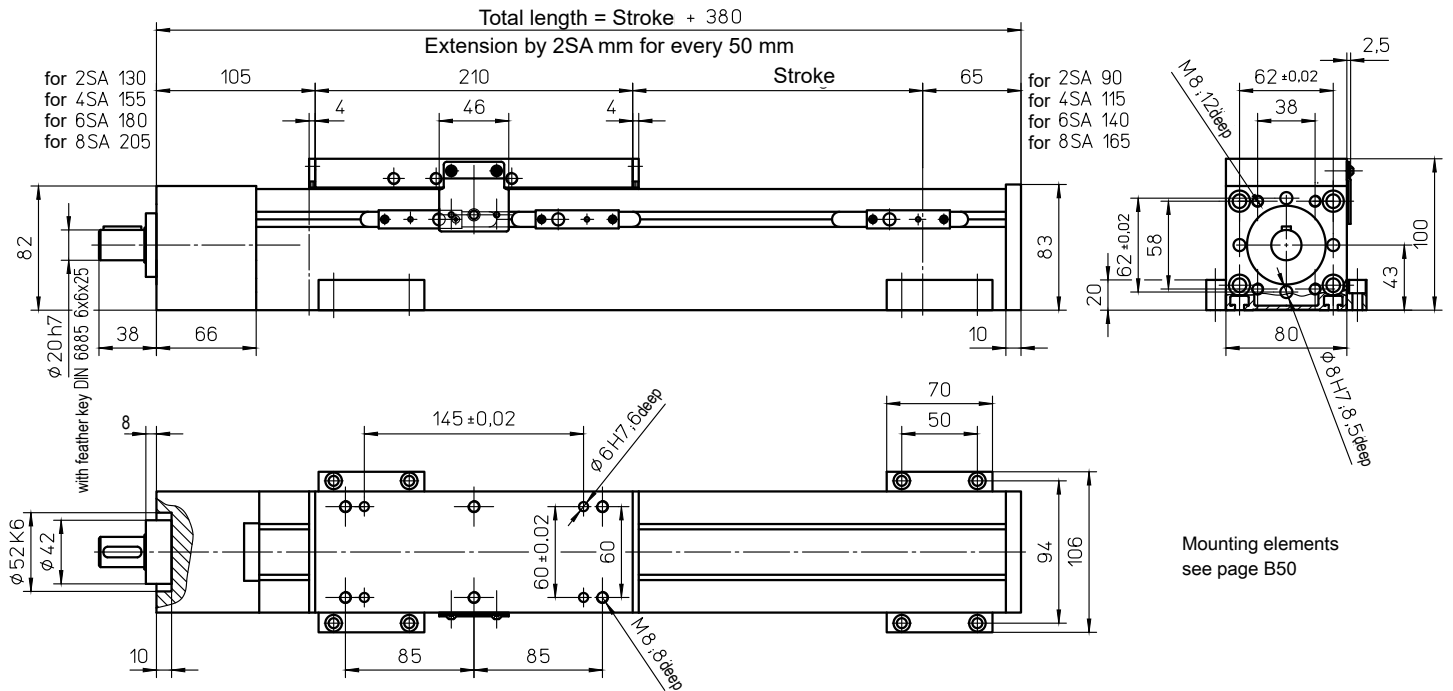

Weights

SGV

Basic length without stroke:	6.40 kg
100 mm stroke:	0.95 kg
Entire carriage 210 mm:	1.60 kg
Max. total length:	5600 mm
(longer on request)	

Technical Data

SGV

Max. speed:	2.50 m/s
Max. acceleration:	20 m/s ²
Repeat accuracy:	± 0.03 mm (KGT)
Idle torque:	1.00 Nm

Forces and moments

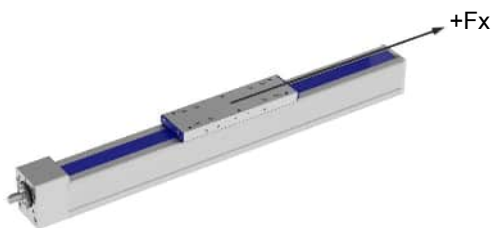

SGV	
Forces	Dynamic [N]
F _x	6000
F _y	-
F _z	-
-F _z	-
Moments	Dynamic [Nm]
M _x	-
M _y	-
M _z	-

"-" => Must have an external guide.

Drive element

KGT

Max. rotation speed:	3000 min ⁻¹
Diameter:	25 mm
Pitch:	5 / 10 / 25 / 50 mm
Moment of inertia:	2.25 · 10 ⁻⁴ kgm ² /m

Spindle support (SA)

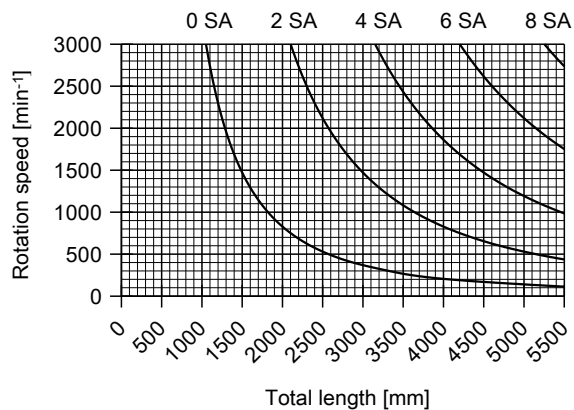

Special design: Spindle support with damping ring (extension of total length: 10 mm for every 2 SA)

with toothed belt drive and roller guide (ZRS) or rail guide (ZSS)

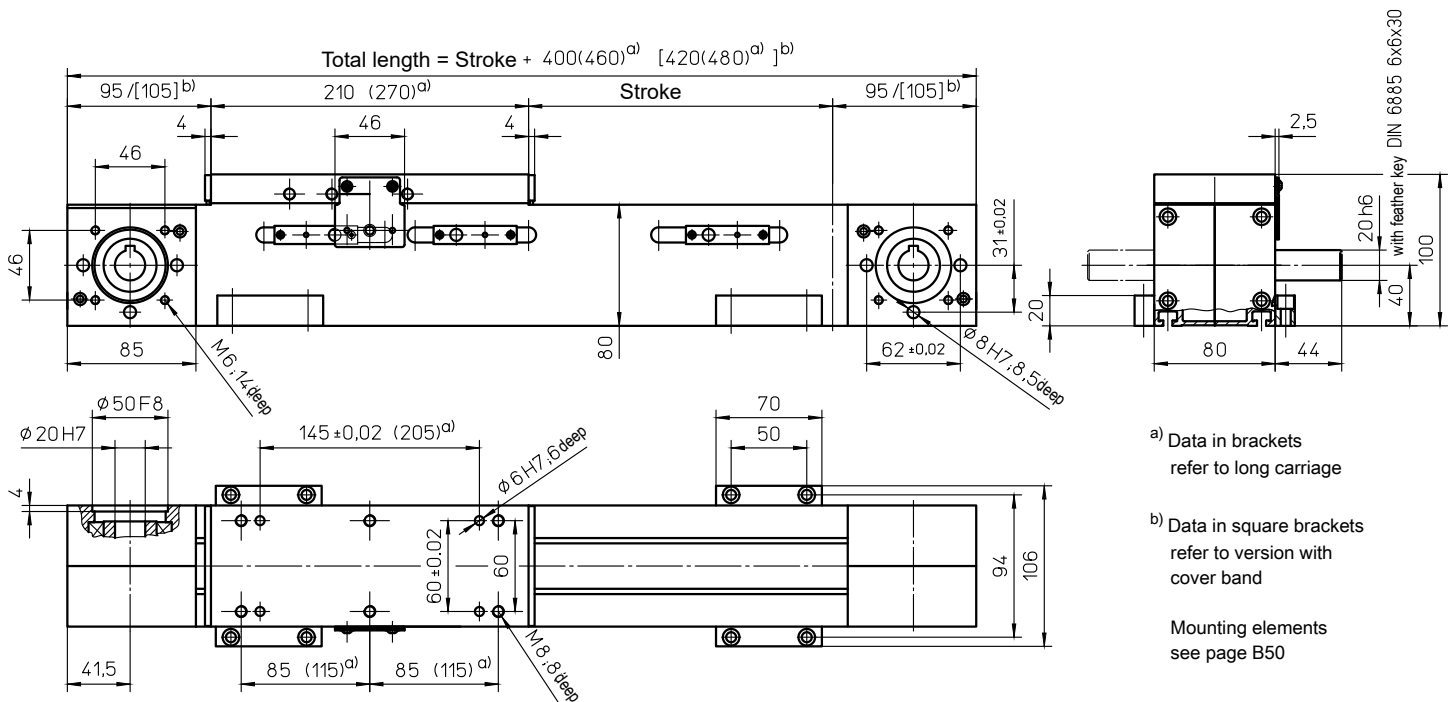

a) Data in brackets refer to long carriage
 b) Data in square brackets refer to version with cover band
 Mounting elements see page B50

Weights	ZRS	ZSS
Basic length without stroke:	5.03 kg	7.80 kg
100 mm stroke:	0.65 kg	0.98 kg
Entire carriage 210 mm:	3.00 kg	2.75 kg
Entire carriage 270 mm:	3.70 kg	3.25 kg
Max. total length: (longer on request)	8000 mm	

Technical Data	ZRS	ZSS
Max. speed:	8.00 m/s	5.00 m/s
Max. acceleration:	40 m/s ²	
Repeat accuracy:	± 0.08 mm	
Idle torque:	1.80 Nm	
Moment of inertia:	4.20 · 10 ⁻³ kgm ²	4.00 · 10 ⁻³ kgm ²
Drive element:	Toothed belt 32 AT10	
Stroke per revolution:	210 mm	

Forces and moments

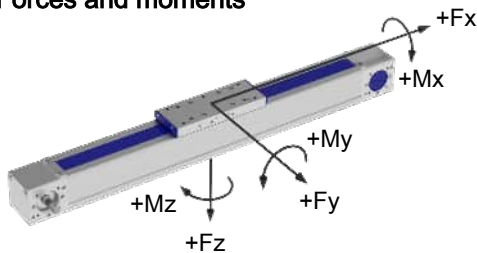

	ZRS	ZSS
Forces	Dynamic [N]	
$F_x^{d)}$	2200	
F_y	1000	1600
F_z	2500	4000
$-F_z$	1500	3000
Moments	Dynamic [Nm]	
M_x	100	300
M_y	300 (400)	500 (640)
M_z	180 (250)	500 (640)

^{d)} Maximum value (see diagram "F_x-v-Diagram")
 Data in brackets refer to long carriage plate (270)

F_x - v - Diagram

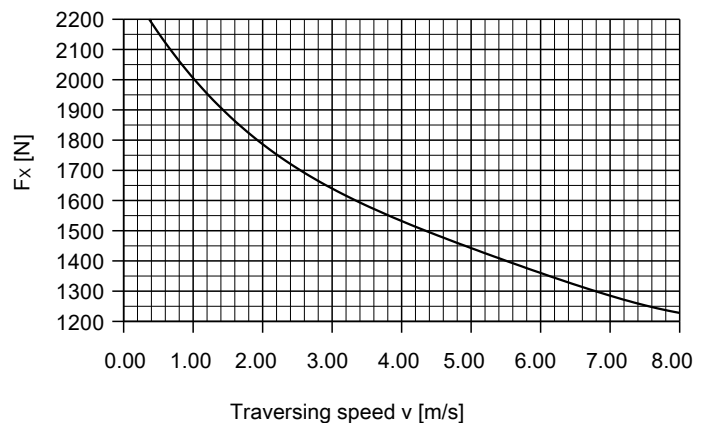

with toothed belt drive and roller guide (ARS) or rail guide (ASS)

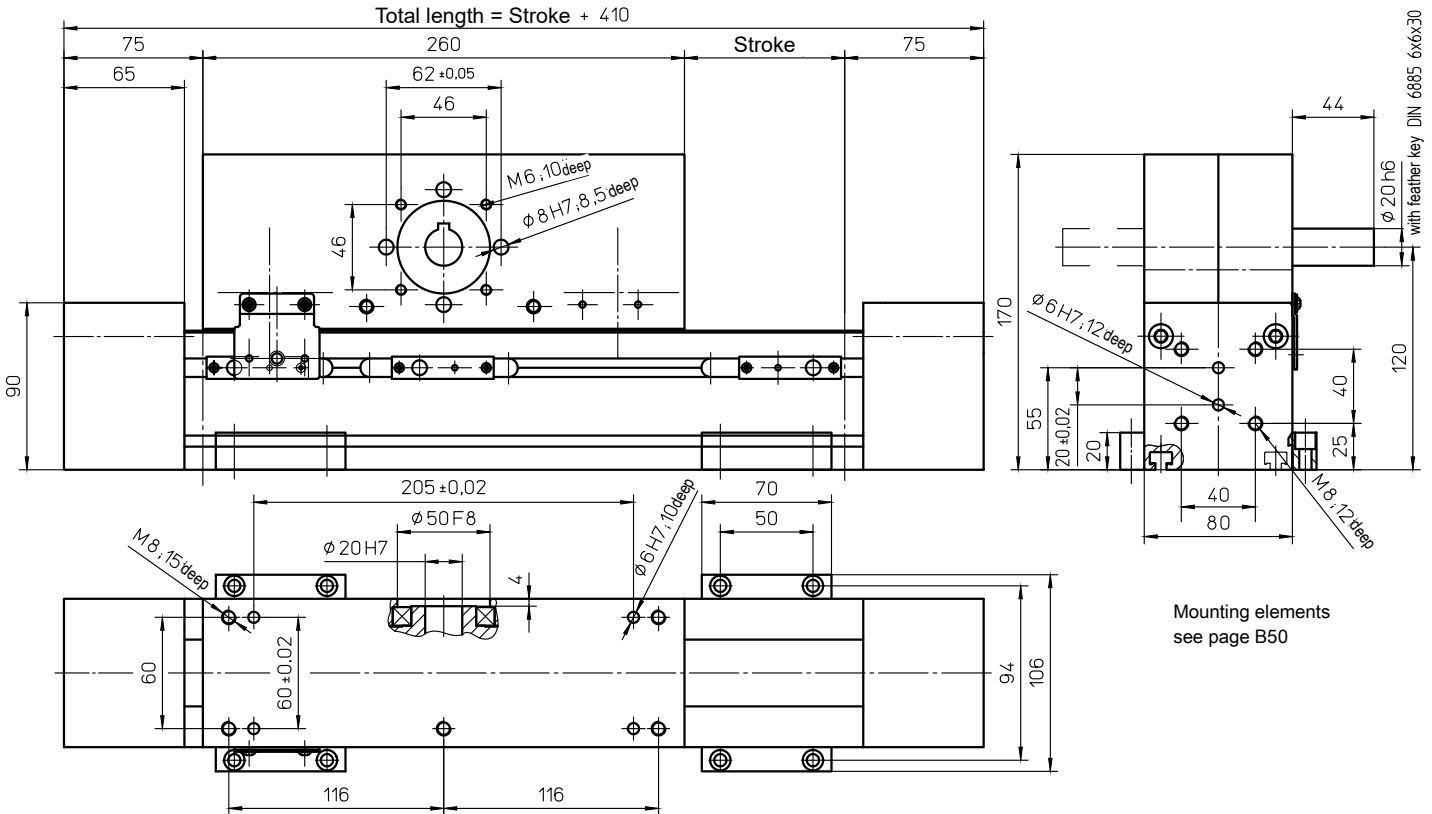

Weights	ARS	ASS
Basic length without stroke:	10.80 kg	12.10 kg
100 mm stroke:	0.63 kg	0.96 kg
Entire carriage 260 mm:	6.30 kg	6.30 kg
Max. total length: (longer on request)	8000 mm	

Technical Data	ARS	ASS
Max. speed:	8.00 m/s	5.00 m/s
Max. acceleration:	40 m/s ²	
Repeat accuracy:	± 0.08 mm	
Idle torque:	1.80 Nm	
Moment of inertia:	9.20 · 10 ⁻³ kgm ² 8.60 · 10 ⁻³ kgm ²	
Drive element:	Toothed belt 32 AT10	
Stroke per revolution:	220 mm	

Forces and moments

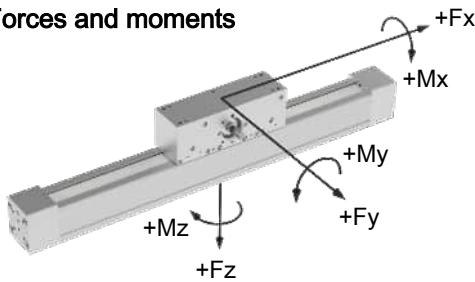

	ARS	ASS
Forces	Dynamic [N]	
F _x ^{d)}	1300	
F _y	1000	1600
F _z	2500	4000
-F _z	1500	3000
Moments	Dynamic [Nm]	
M _x	100	300
M _y	300	500
M _z	180	500

^{d)} Maximum value (see diagram "F_x-v-Diagram")

F_x - v - Diagram

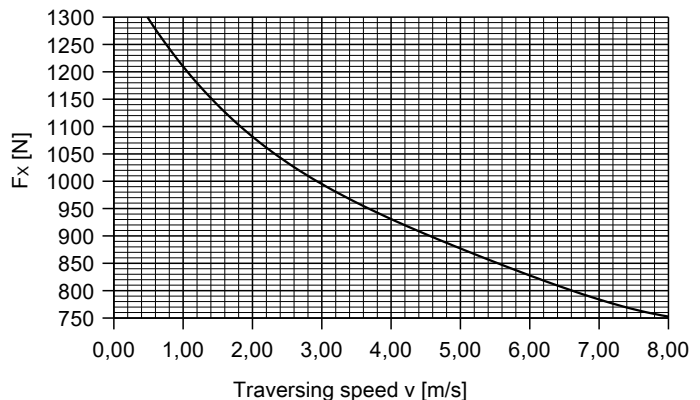

For mechanical linear drives with roller guide, the static load rating "C_{stat}" (page TL 11) applies for static loads.

with toothed belt drive and roller guide (ZRS) or rail guide (ZSS)

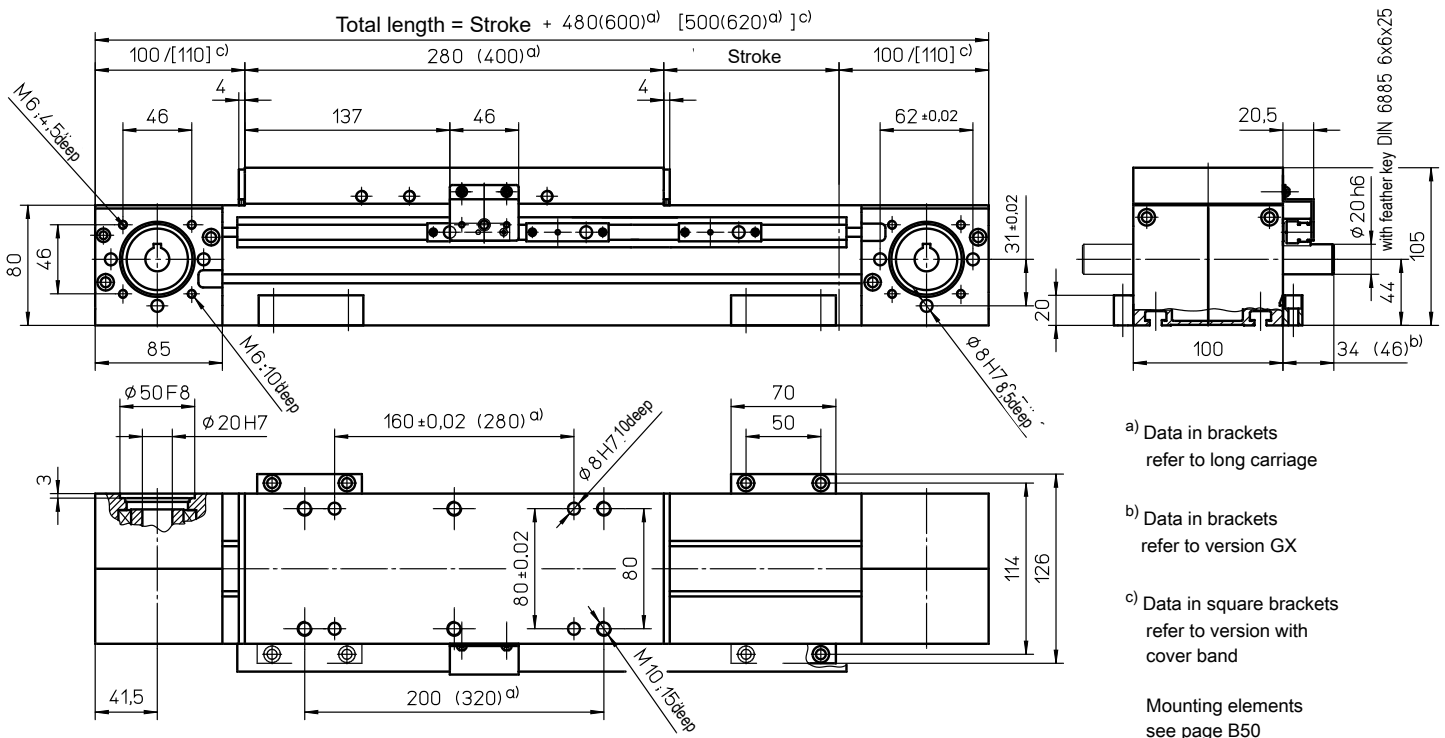

Weights	ZRS	ZSS
Basic length without stroke:	9.50 kg	9.10 kg
100 mm stroke:	1.10 kg	1.45 kg
Entire carriage 280 mm:	4.10 kg	3.80 kg
Entire carriage 400 mm:	5.85 kg	5.43 kg

Max. total length: 7900 mm
 (longer on request)

Technical Data	ZRS	ZSS
Max. speed:	8.00 m/s	5.00 m/s
Max. acceleration:	40 m/s ²	
Repeat accuracy:	± 0.08 mm	
Idle torque:	2.50 Nm	
Moment of inertia:	1.30 · 10 ⁻² kgm ²	1.26 · 10 ⁻² kgm ²
Drive element:	Toothed belt 40 AT10	
Stroke per revolution:	200 mm	

Forces and moments

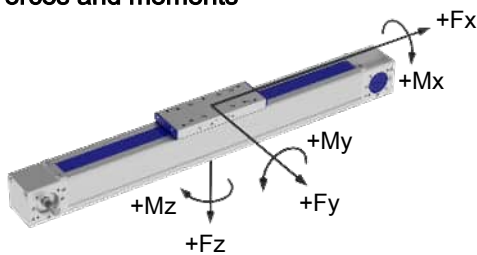

	ZRS	ZSS
Forces	Dynamic [N]	
F_x ^{d)}	2800	
F_y	1000	
F_z	2500	3000
-F_z	1200	2000
Moments	Dynamic [Nm]	
M_x	200	200
M_y	250 (350)	300 (420)
M_z	200 (280)	300 (420)

^{d)} Maximum value (see diagram "F_x-v-Diagram")
 Data in brackets refer to long carriage plate (400)

F_x - v - Diagram

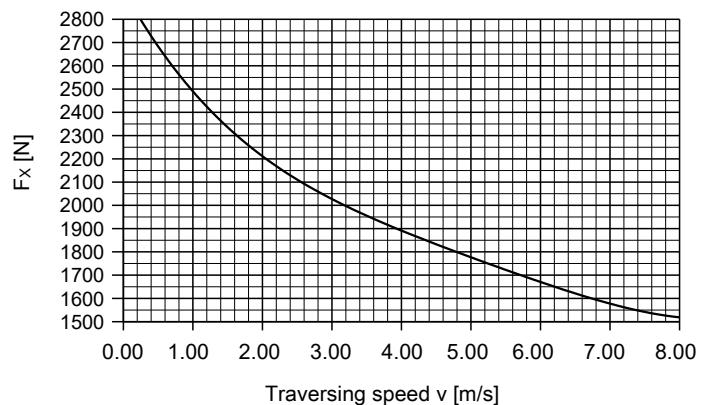

For mechanical linear drives with roller guide, the static load rating "C_{stat}" (page TL 11) applies for static loads.

with toothed belt drive and double linear guide (ZSS)

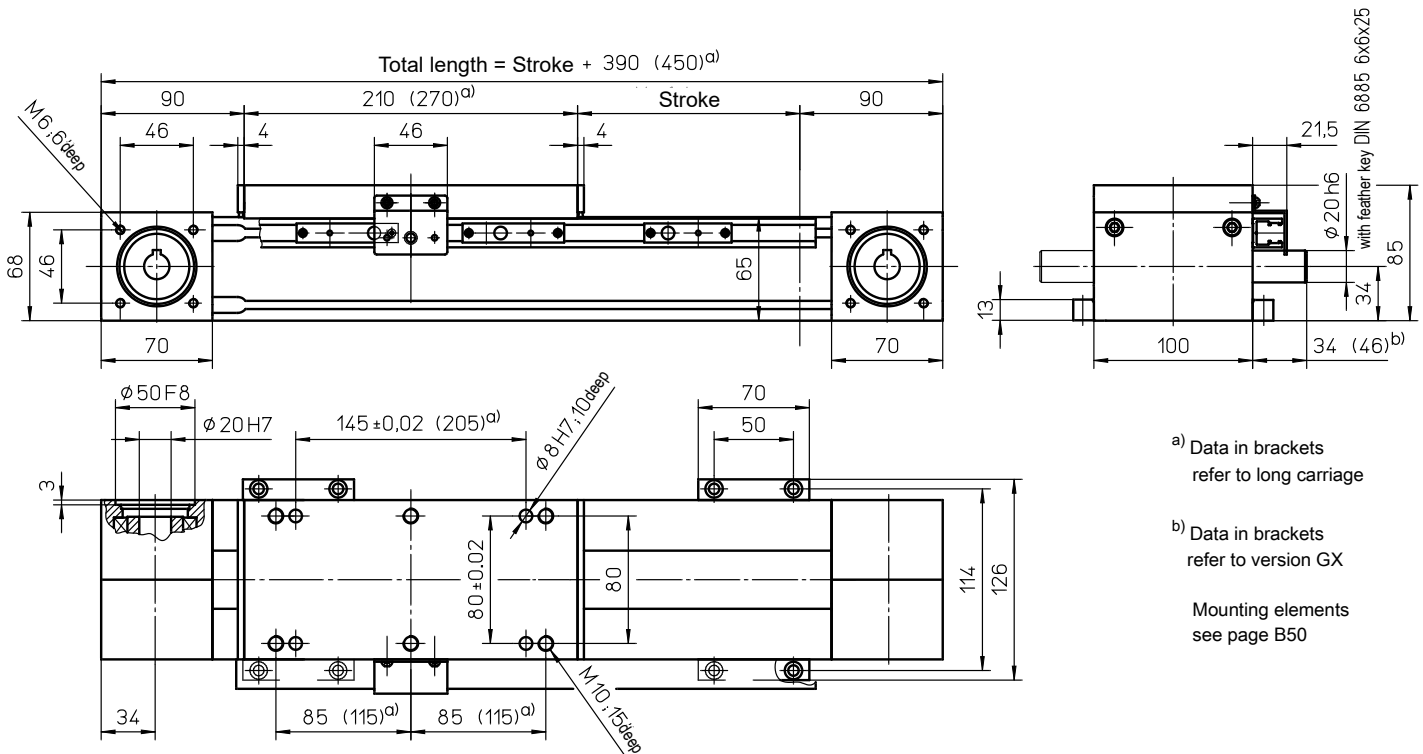

a) Data in brackets refer to long carriage

b) Data in brackets refer to version GX

Mounting elements see page B50

Weights ZSS

Basic length without stroke:	6.80 kg
100 mm stroke:	0.75 kg
Entire carriage 210 mm:	3.50 kg
Entire carriage 270 mm:	4.10 kg
Max. total length: (longer on request)	8100 mm

Technical Data ZSS

Max. speed:	5.00 m/s
Max. acceleration:	60 m/s ²
Repeat accuracy:	± 0.08 mm
Idle torque:	5.00 Nm
Moment of inertia:	2.80 · 10 ⁻³ kgm ²
Drive element:	Toothed belt 40 AT10-E
Stroke per revolution:	160 mm

Forces and moments

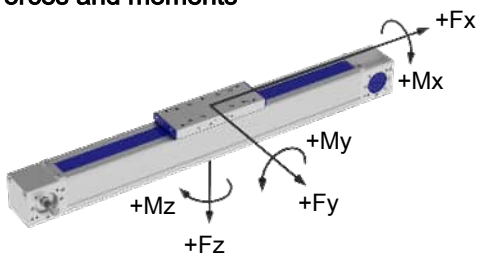

ZSS	
Forces	Dynamic [N]
F _x ^{d)}	1500
F _y	1800
F _z	4000
-F _z	3000
Moments	Dynamic [Nm]
M _x	350
M _y	750 (1000)
M _z	750 (1000)

^{d)} Maximum value (see diagram "F_x-v-Diagram")
Data in brackets refer to long carriage plate (270)

F_x - v - Diagram

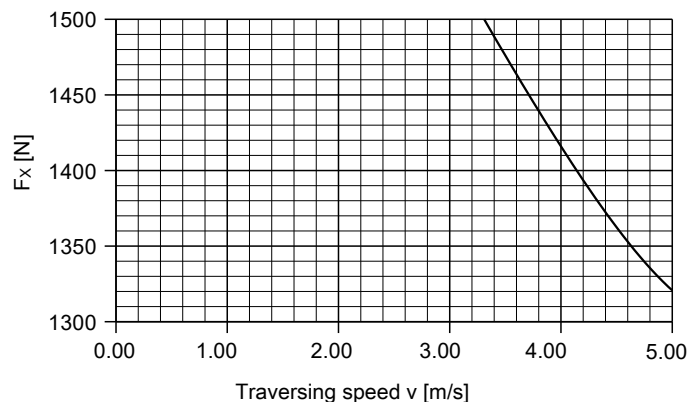

with toothed belt drive and double rail guide (ASS)

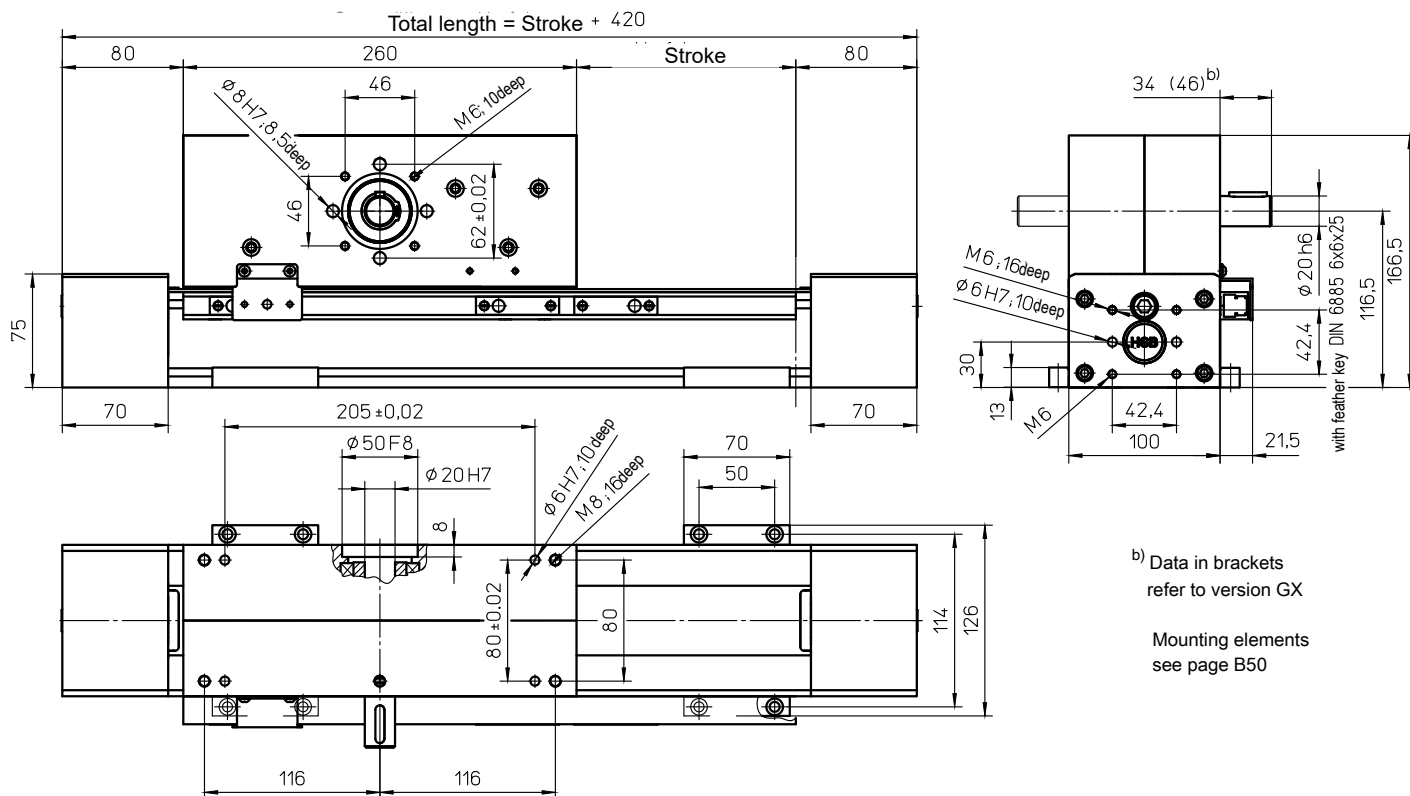

b) Data in brackets refer to version GX

Mounting elements see page B50

Weights

ASS

Basic length without stroke:	14.00 kg
100 mm stroke:	0.90 kg
Carriage drive 260 mm:	8.60 kg
Max. total length: (longer on request)	8100 mm

Technical Data

ASS

Max. speed:	5.00 m/s
Max. acceleration:	60 m/s ²
Repeat accuracy:	± 0.08 mm
Idle torque:	2.50 Nm
Moment of inertia:	1.20 · 10 ⁻² kgm ²
Drive element:	Toothed belt 40 AT10-E
Stroke per revolution:	240 mm

Forces and moments

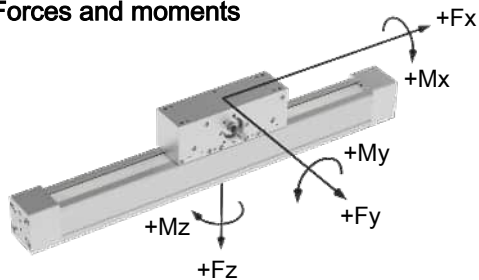

ASS	
Forces	Dynamic [N]
$F_x^{d)}$	2200
F_y	1800
F_z	4000
$-F_z$	3000
Moments	Dynamic [Nm]
M_x	350
M_y	950
M_z	950

d) Maximum value (see diagram "F_x-v-Diagram")

F_x - v - Diagram

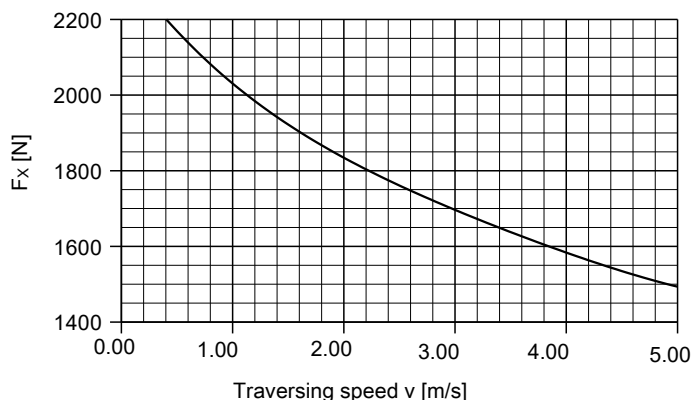

with ball screw (KGT) and double linear guide (SSS)

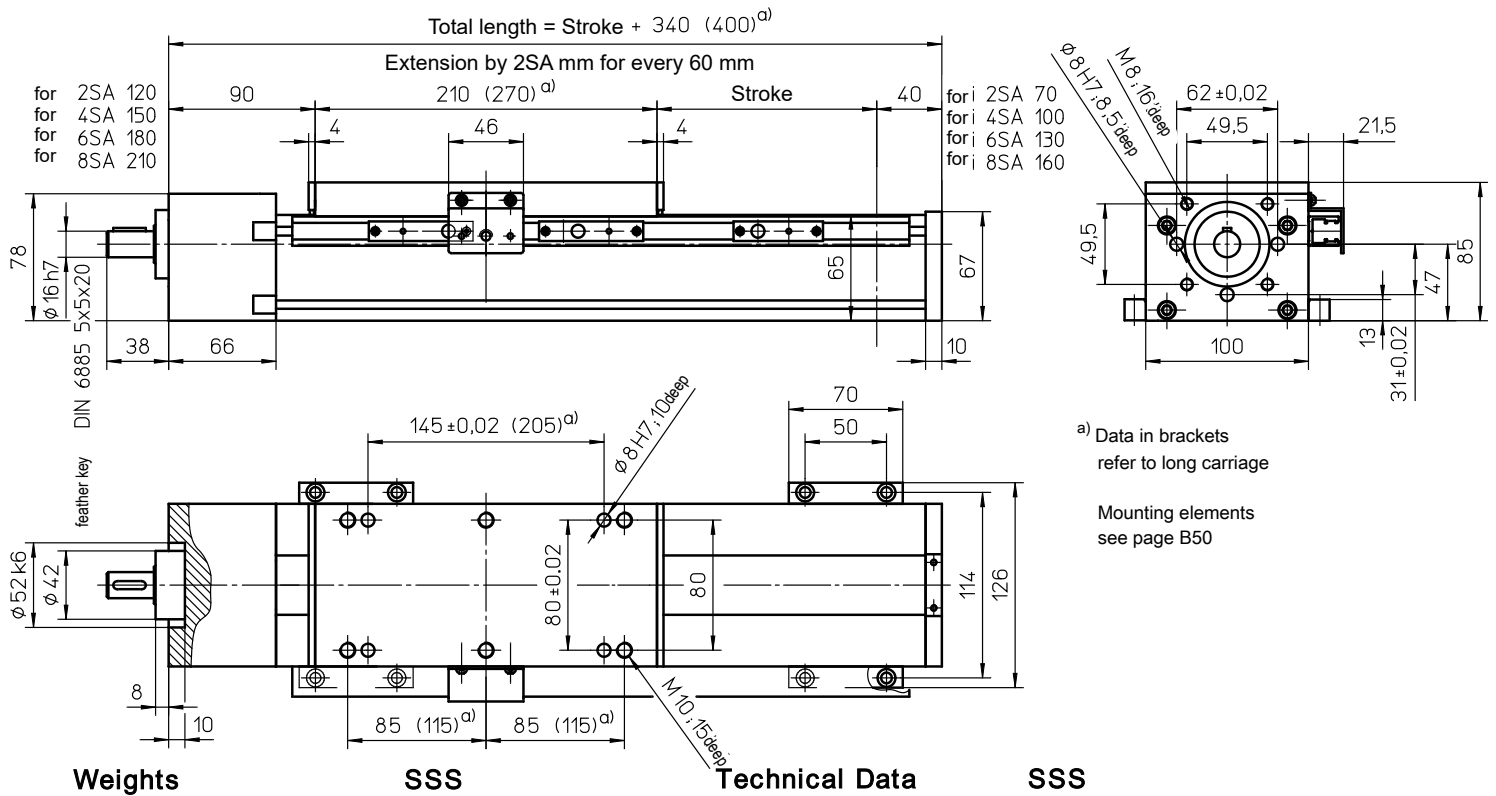

Weights

SSS

Basic length without stroke:	6.20 kg
100 mm stroke:	0.75 kg
Entire carriage 210 mm:	3.40 kg
Entire carriage 270 mm:	4.00 kg

Max. total length: 5600 mm
(longer on request)

Technical Data

SSS

Max. speed:	2.50 m/s
Max. acceleration:	20 m/s ²
Repeat accuracy:	± 0.03 mm (KGT)
Idle torque:	1.30 Nm

Forces and moments

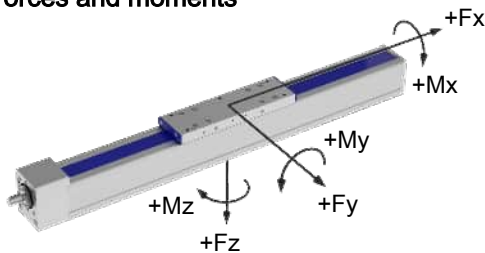

	SSS
Forces	Dynamic [N]
F_x	4000
F_y	1800
F_z	4000
-F_z	3000
Moments	Dynamic [Nm]
M_x	350
M_y	750 (1000)
M_z	750 (1000)

Data in brackets refer to long carriage plate (270)

Drive element

KGT

Max. rotation speed:	3000 min ⁻¹
Diameter:	20 mm
Pitch:	5 / 10 / 20 / 50 mm
Moment of inertia:	8.40 · 10 ⁻⁵ kgm ² /m

Spindle support (SA)

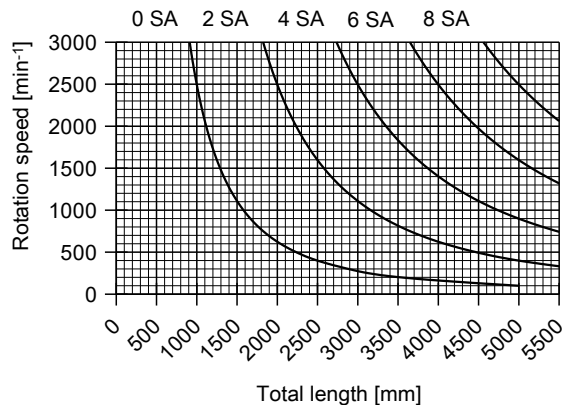

Special design: Spindle support with damping ring (extension of total length: 10 mm for every 2 SA)
Version with double nut not possible.

with toothed belt drive and roller guide (ZRS) or rail guide (ZSS)

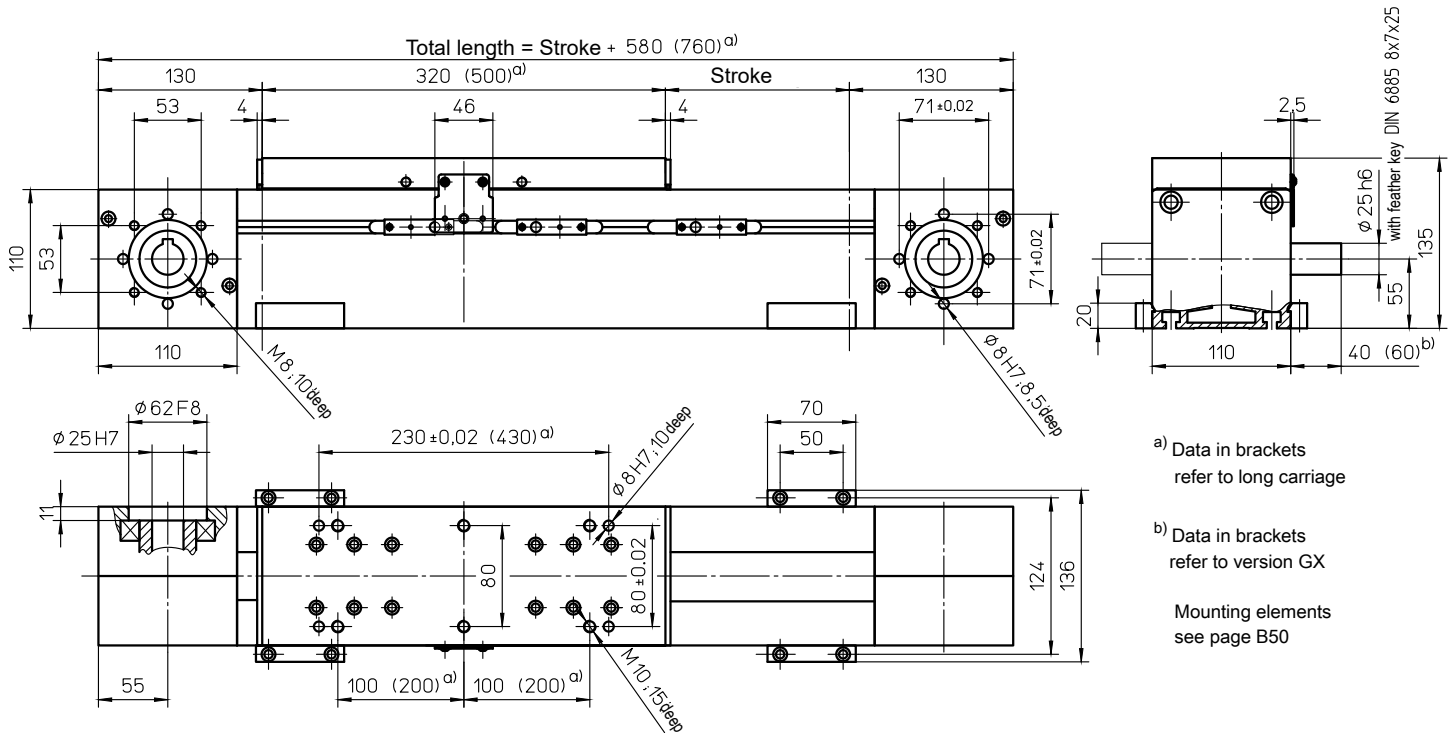

Weights	ZRS	ZSS
Basic length without stroke:	15.70 kg	18.00 kg
100 mm stroke:	1.50 kg	2.10 kg
Entire carriage 320 mm:	4.80 kg	5.20 kg
Entire carriage 500 mm:	7.50 kg	8.20 kg

Max. total length: 8100 mm
(longer on request)

Technical Data	ZRS	ZSS
Max. speed:	8.00 m/s	5.00 m/s
Max. acceleration:	60 m/s ²	
Repeat accuracy:	± 0.08 mm	
Idle torque:	3.50 Nm	
Moment of inertia:	1.80 · 10 ⁻² kgm ²	1.60 · 10 ⁻² kgm ²
Drive element:	Toothed belt 50 ATL10	
Stroke per revolution:	300 mm	

Forces and moments

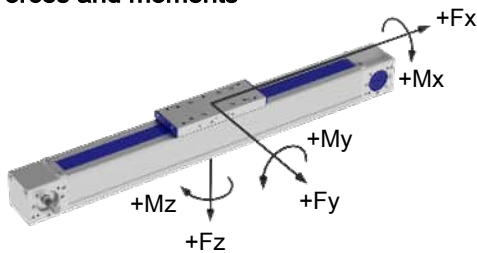

	ZRS	ZSS
Forces	Dynamic [N]	
F_x^{d)}	4000	
F_y	2000	3000
F_z	5000	8000
-F_z	2500	4000
Moments	Dynamic [Nm]	
M_x	300	400
M_y	600 (800)	800 (1200)
M_z	450 (550)	600 (800)

^{d)} Maximum value (see diagram "F x -v-Diagram")
Data in brackets refer to long carriage plate (500)

F_x - v - Diagram

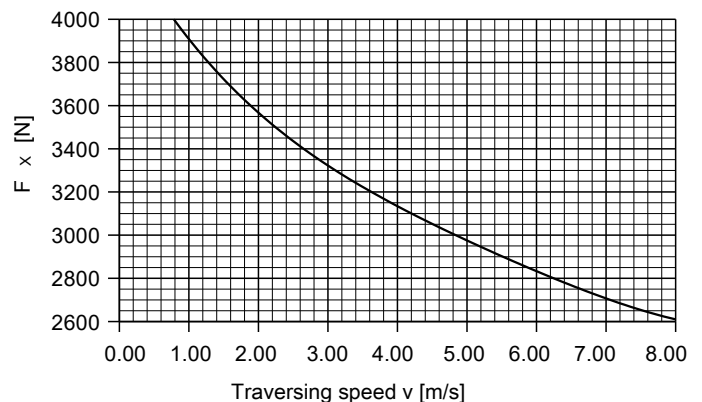

For mechanical linear drives with roller guide, the static load rating "C_{stat}" (page TL 11) applies for static loads.

with toothed belt drive and roller guide (ARS) or rail guide (ASS)

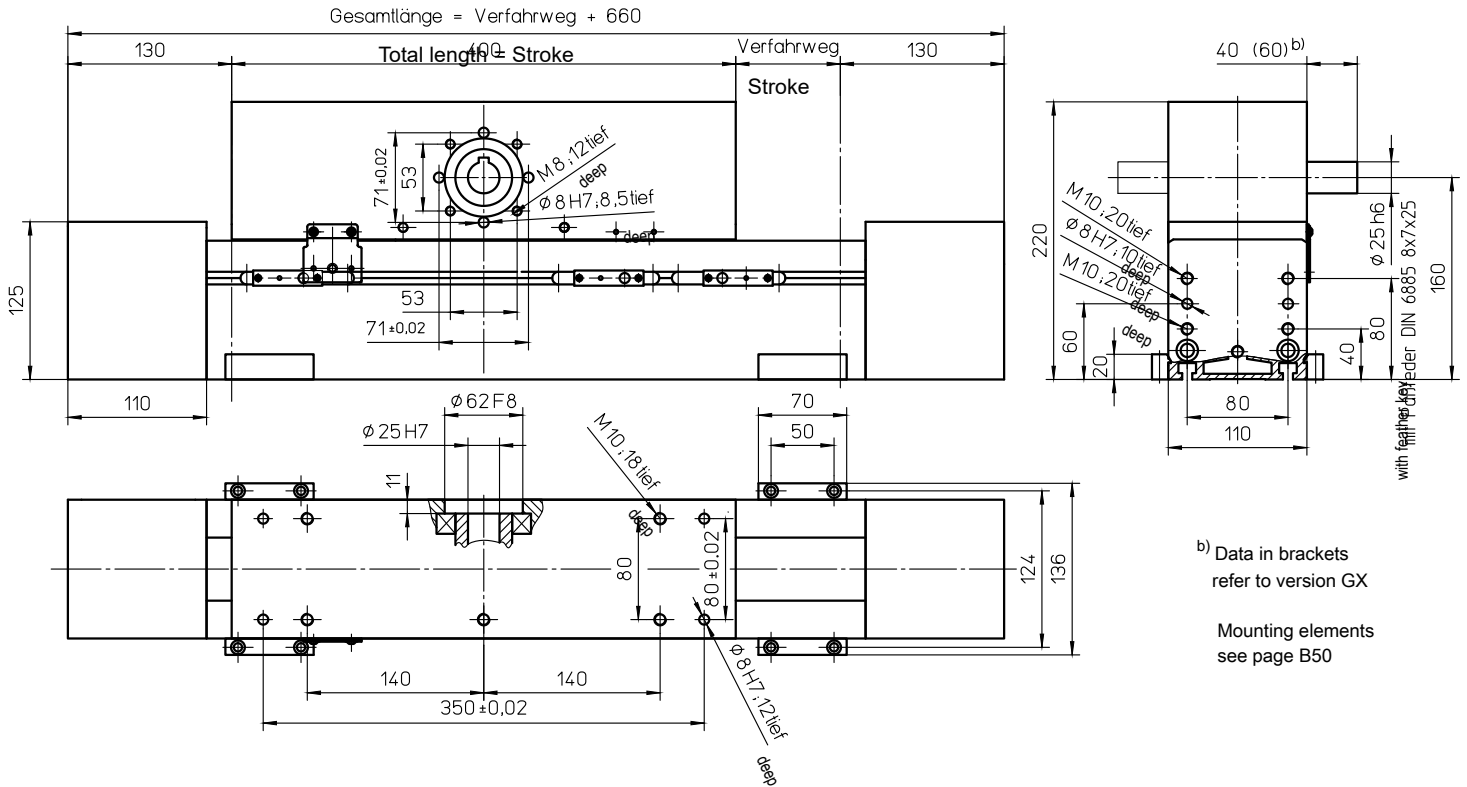

b) Data in brackets refer to version GX
Mounting elements see page B50

Weights	ARS	ASS
Basic length without stroke:	27.00 kg	29.00 kg
100 mm stroke:	1.20 kg	1.40 kg
Carriage drive 400 mm:	15.00 kg	16.00 kg
Max. total length: (longer on request)	8100 mm	

Technical Data	ARS	ASS
Max. speed:	8.00 m/s	5.00 m/s
Max. acceleration:	60 m/s ²	
Repeat accuracy:	± 0.08 mm	
Idle torque:	3.50 Nm	
Moment of inertia:	3.50 · 10 ⁻² kgm ²	3.70 · 10 ⁻² kgm ²
Drive element:	Toothed belt 50 AT10-E	
Stroke per revolution:	300 mm	

Forces and moments

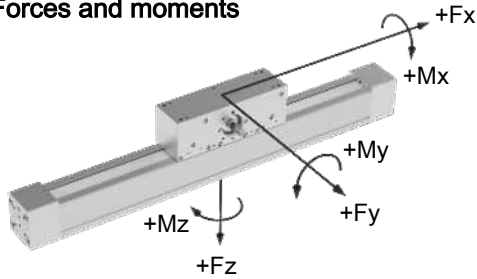

	ARS	ASS
Forces	Dynamic [N]	
F _x ^{d)}	2000	
F _y	2000	3000
F _z	5000	8000
-F _z	2500	4000
Moments	Dynamic [Nm]	
M _x	300	400
M _y	600	800
M _z	450	600

^{d)} Maximum value (see diagram "F_x-v-Diagram")

F_x - v - Diagram

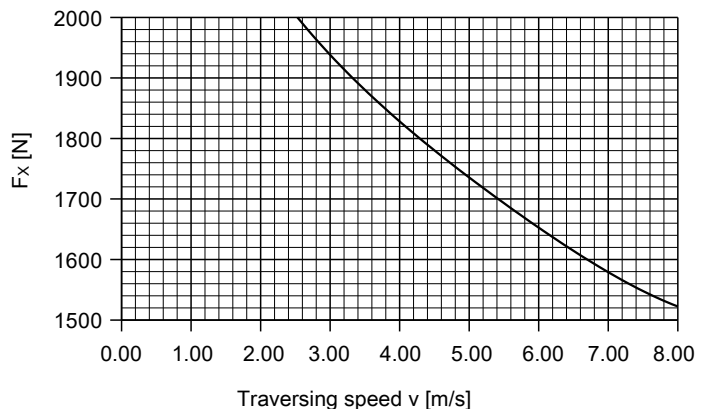

For mechanical linear drives with roller guide, the static load rating "C_{stat}" (page TL 11) applies for static loads.

with ball screw (KGT) and roller guide (SRS) or rail guide (SSS)

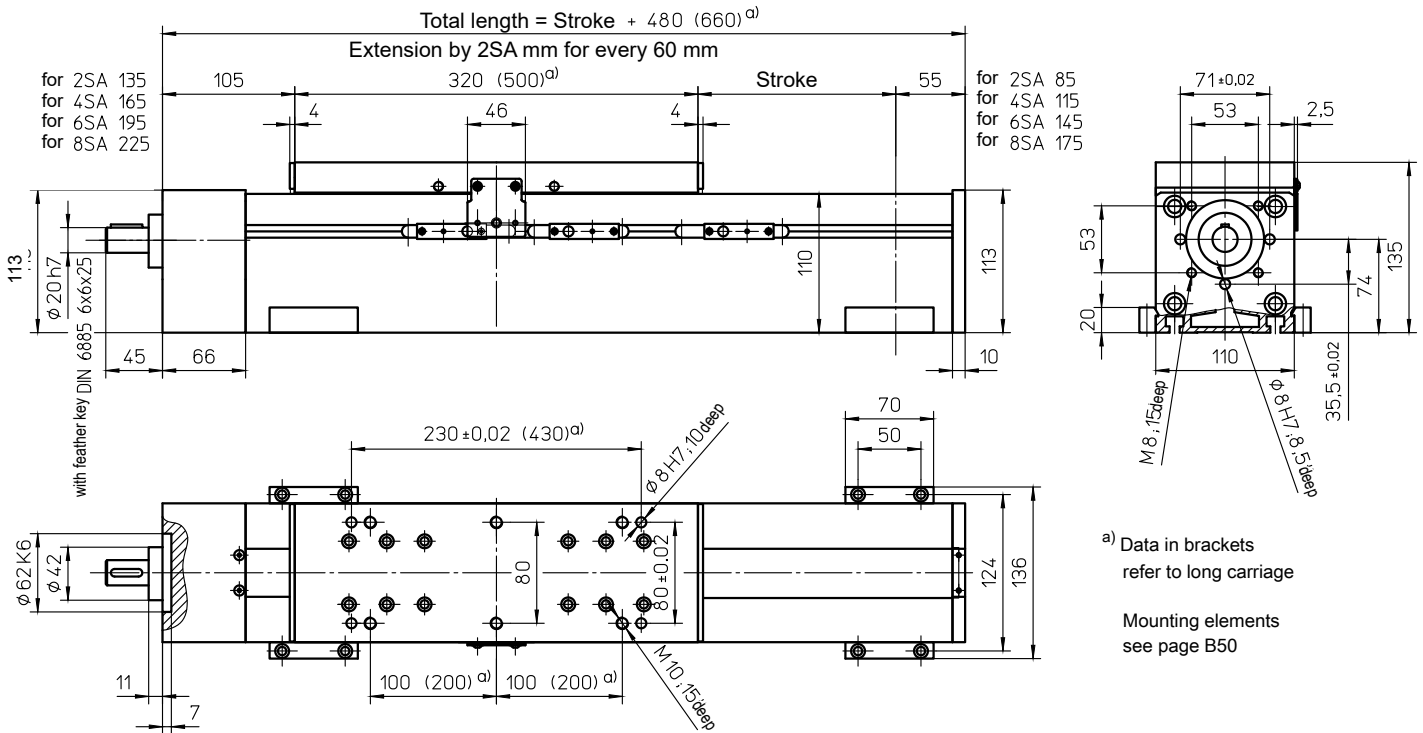

Weights	SRS	SSS
Basic length without stroke:	12.50 kg	13.50 kg
100 mm stroke:	1.40 kg	1.70 kg
Entire carriage 320 mm:	5.80 kg	5.30 kg
Entire carriage 500 mm:	9.10 kg	8.30 kg

Max. total length: 5600 mm
 (longer on request)

Forces and moments

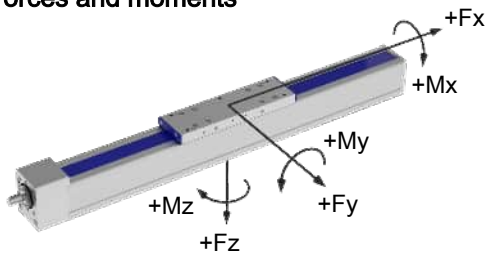

	SRS	SSS
Forces	Dynamic [N]	
F_x	6000	
F_y	2000	3000
F_z	5000	8000
$-F_z$	2500	4000
Moments	Dynamic [Nm]	
M_x	300	400
M_y	600 (800)	800 (1200)
M_z	450 (550)	600 (800)

Data in brackets refer to long carriage plate (500)

Technical Data	SRS	SSS
Max. speed:	2.50 m/s	
Max. acceleration:	20 m/s ²	
Repeat accuracy:	± 0.03 mm (KGT)	
Idle torque:	1.00 Nm	1.50 Nm

Drive element KGT

Max. rotation speed:	3000 min ⁻¹
Diameter:	25 mm
Pitch:	5 / 10 / 25 / 50 mm
Moment of inertia:	2.25 · 10 ⁻⁴ kgm ² /m

Spindle support (SA)

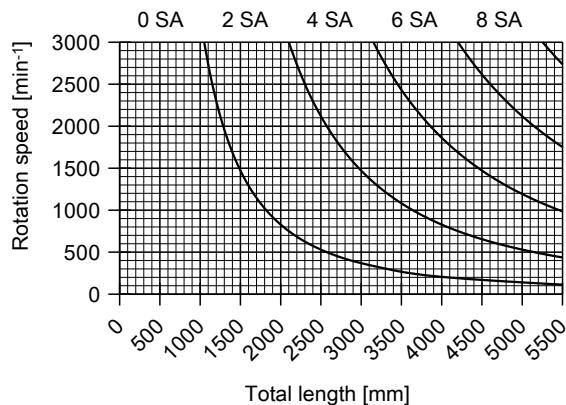

For mechanical linear drives with roller guide,

the static load rating "C_{stat}" (page TL 11) applies for static loads.

Special design: Spindle support with damping ring (extension of total length: 10 mm for every 2 SA)

Version with double nut ("MM") only available with pitch "5", "10" and "25".

with toothed belt drive and roller guide (ZRS) or rail guide (ZSS)

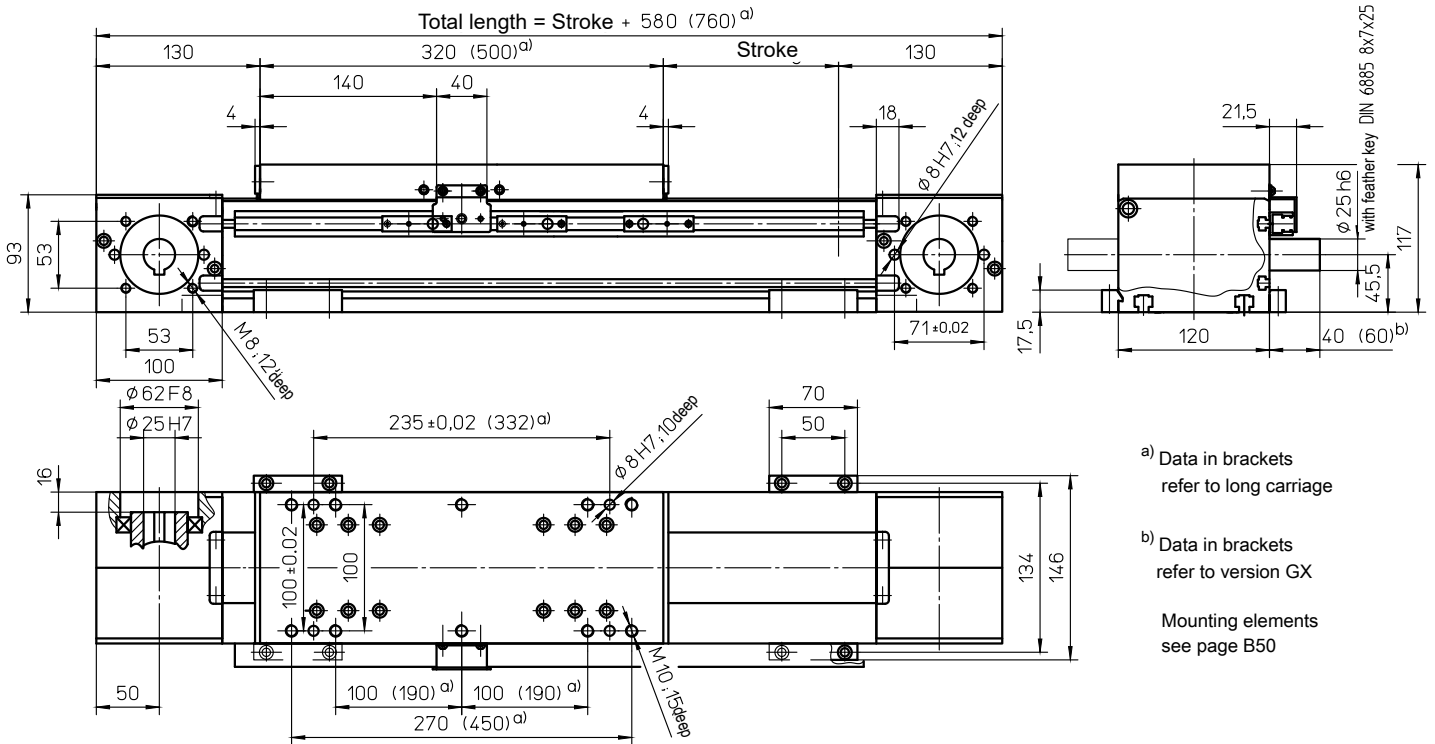

a) Data in brackets refer to long carriage

b) Data in brackets refer to version GX

Mounting elements see page B50

Weights	ZRS	ZSS
Basic length without stroke:	12.50 kg	13.00 kg
100 mm stroke:	1.30 kg	1.70 kg
Entire carriage 320 mm:	6.00 kg	6.50 kg
Entire carriage 500 mm:	9.40 kg	10.20 kg

Max. total length: 8100 mm
(longer on request)

Technical Data	ZRS	ZSS
Max. speed:	8.00 m/s	5.00 m/s
Max. acceleration:	60 m/s ²	
Repeat accuracy:	± 0.08 mm	
Idle torque:	3.20 Nm	
Moment of inertia:	1.50 · 10 ⁻² kgm ²	1.60 · 10 ⁻² kgm ²
Drive element:	Toothed belt 50 ATL10	
Stroke per revolution:	240 mm	

Forces and moments

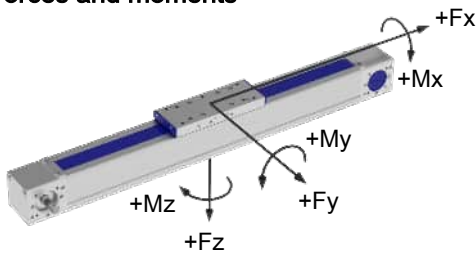

	ZRS	ZSS
Forces	Dynamic [N]	
F_x^{d)}	4000	
F_y	2500	3000
F_z	6000	8000
-F_z	3000	4000
Moments	Dynamic [Nm]	
M_x	350	400
M_y	700 (1000)	1200 (1500)
M_z	500 (1000)	600 (800)

^{d)} Maximum value (see diagram "F_x-v-Diagram")
Data in brackets refer to long carriage plate (500)

F_x - v - Diagram

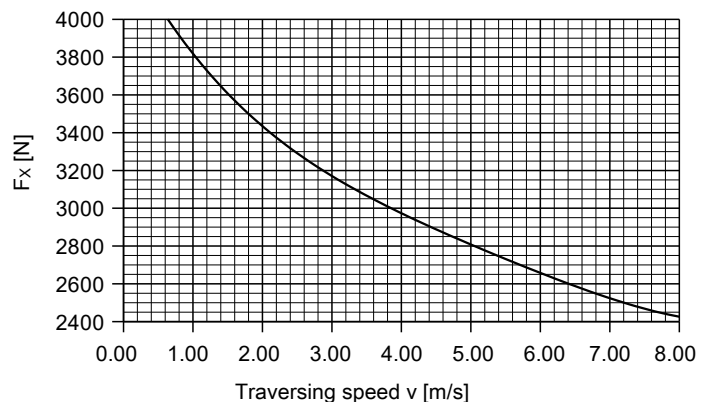

with toothed belt drive and rail guide (ZSS)

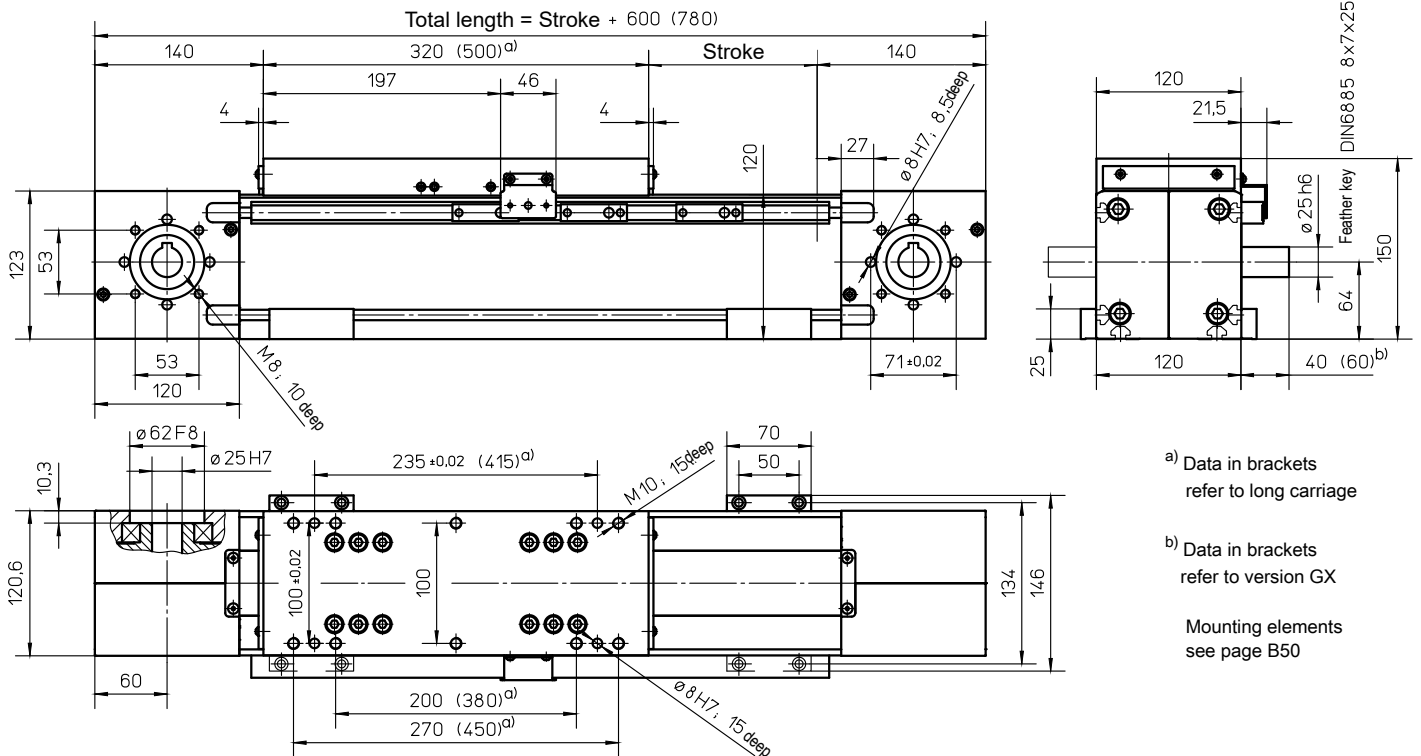

a) Data in brackets refer to long carriage

b) Data in brackets refer to version GX

Mounting elements see page B50

Weights

ZSS

Basic length without stroke:	21.0 kg
100 mm stroke:	2.40 kg
Entire carriage 320 mm:	8.00 kg
Entire carriage 500 mm:	12.00 kg
Max. total length: (longer on request)	8100 mm

Technical Data

ZSS

Max. speed:	5.00 m/s
Max. acceleration:	60 m/s ²
Repeat accuracy:	± 0.08 mm
Idle torque:	4.50 Nm
Moment of inertia:	2.10 · 10 ⁻² kgm ²
Drive element:	Toothed belt 60 ATL10
Stroke per revolution:	300 mm

Forces and moments

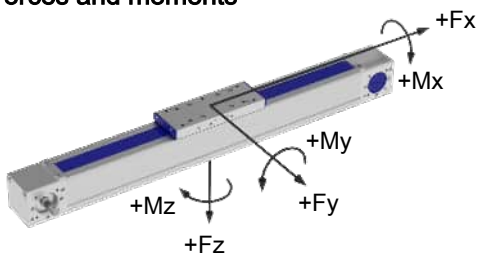

ZSS	
Forces	Dynamic [N]
F_x^{d)}	4800
F_y	4000
F_z	12000
-F_z	6000
Moments	Dynamic [Nm]
M_x	600
M_y	1500 (2800)
M_z	1000 (1800)

^{d)} Maximum value (see diagram "F_x-v-Diagram")
Data in brackets refer to long carriage plate (500)

F_x - v - Diagram

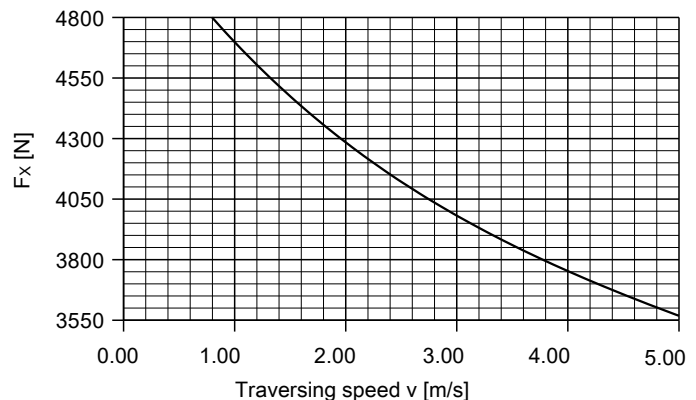

with ball screw (KGT) or rail guide (ZSS)

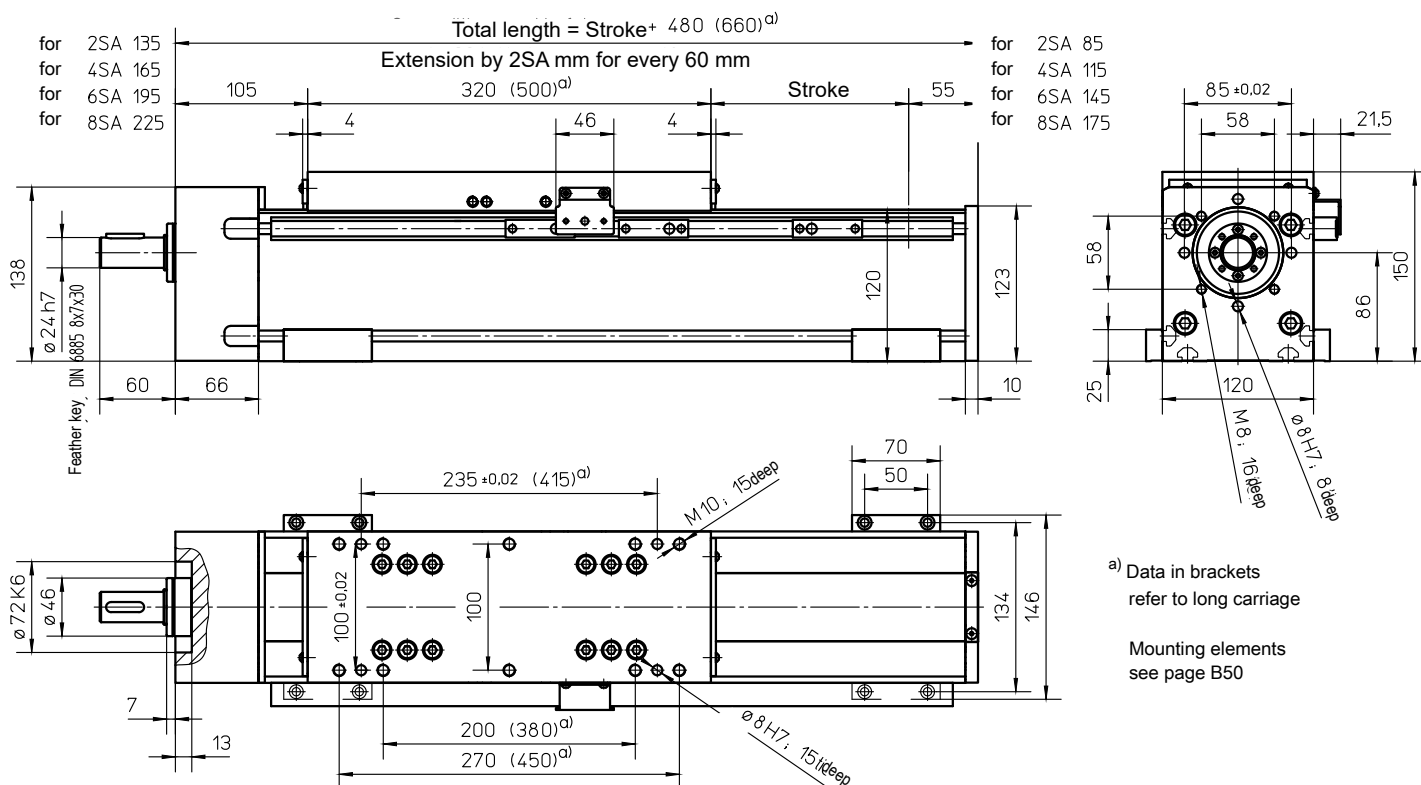

Weights

	SSS
Basic length without stroke:	22.00 kg
100 mm stroke:	2.70 kg
Entire carriage 320 mm:	8.00 kg
Entire carriage 500 mm:	12.00 kg
Max. total length: (longer on request)	5600 mm

Technical Data

	SSS
Max. speed:	3.00 m/s
Max. acceleration:	20 m/s ²
Repeat accuracy:	± 0.03 mm (KGT)
Idle torque:	2.00 Nm

Forces and moments

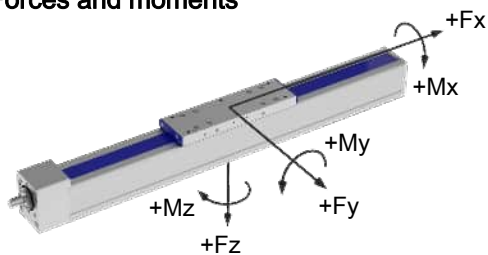

	SSS
Forces	Dynamic [N]
F_x	12000 *
F_y	4000
F_z	12000
-F_z	6000
Moments	Dynamic [Nm]
M_x	600
M_y	1500 (2800)
M_z	1000 (1800)

Data in brackets refer to long carriage plate (500)

* at KGT3240 and 3260: 8000 N

Drive element

	KGT
Max. rotation speed:	3000 min ⁻¹
Diameter:	32 mm
Pitch:	5 / 10 / 20 / 40 / 60 mm
Moment of inertia:	$6.39 \cdot 10^{-4}$ kgm ² /m

Spindle support (SA)

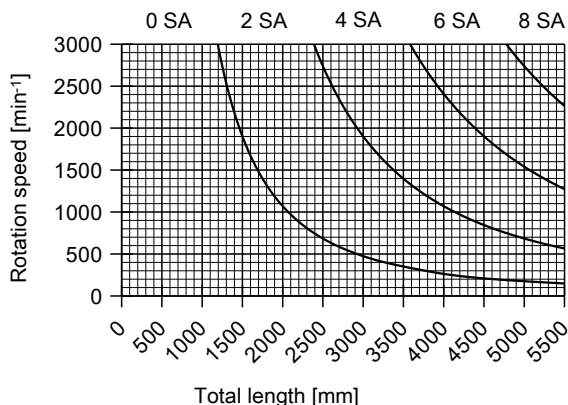

Special design: Spindle support with damping ring (extension of total length: 10 mm for every 2 SA)

Version with double nut ("MM") only available with long carriage (500 mm) and pitch "5", "10" or "20".

with toothed belt drive and roller guide (ZRS) or double linear guide (ZSS)

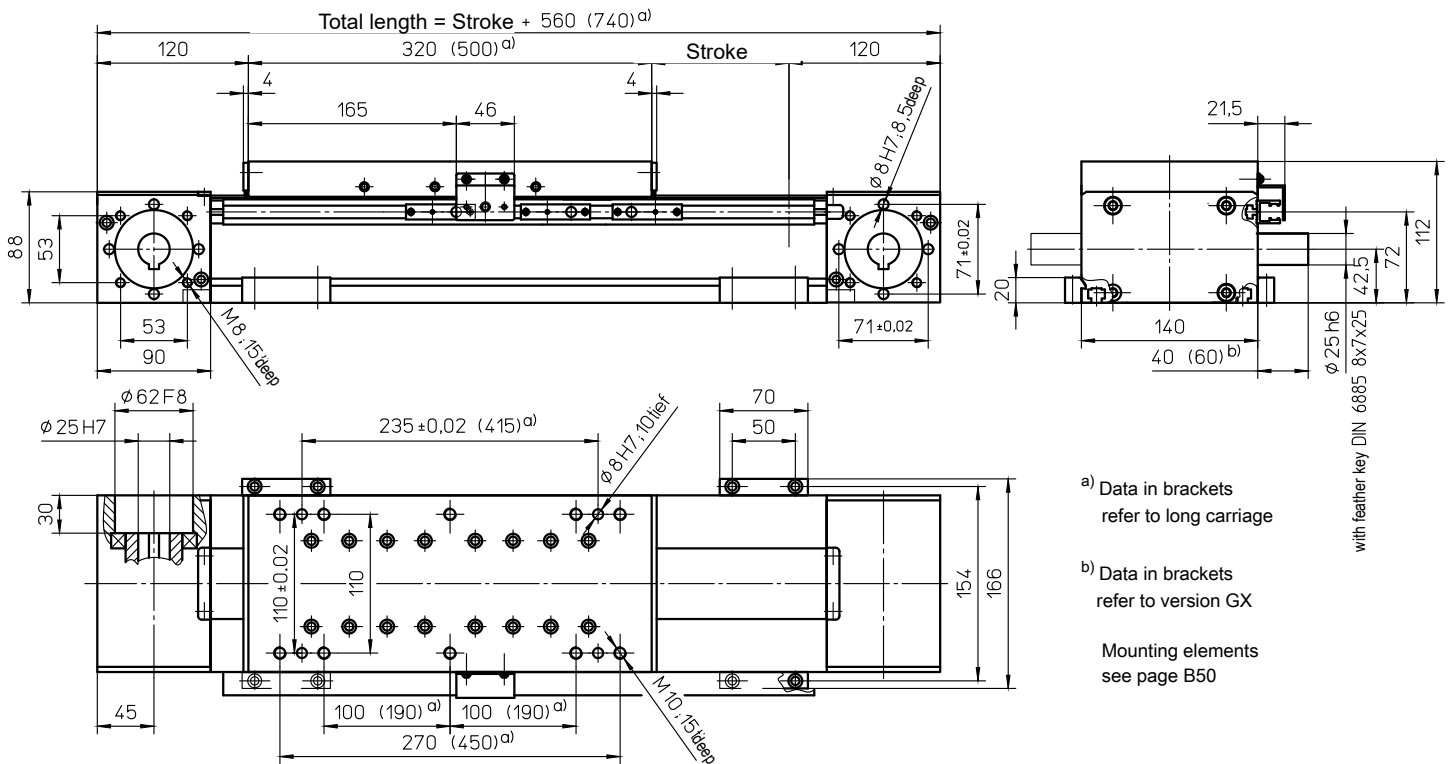

Weights	ZRS	ZSS
Basic length without stroke:	13.50 kg	15.00 kg
100 mm stroke:	1.30 kg	1.70 kg
Entire carriage 320 mm:	7.00 kg	7.50 kg
Entire carriage 500 mm:	11.00 kg	11.70 kg

Max. total length: 8100 mm
(longer on request)

Technical Data	ZRS	ZSS
Max. speed:	8.00 m/s	5.00 m/s
Max. acceleration:	60 m/s ²	
Repeat accuracy:	± 0.08 mm	
Idle torque:	3.50 Nm	
Moment of inertia:	1.90 • 10 ⁻² kgm ²	2.00 • 10 ⁻² kgm ²
Drive element:	Toothed belt 50 AT10-E	
Stroke per revolution:	220 mm	

Forces and moments

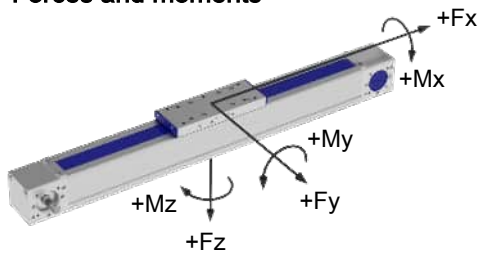

F_x - v - Diagram

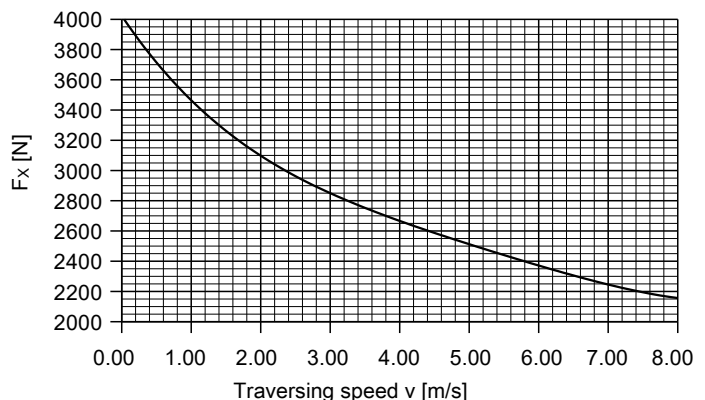

	ZRS	ZSS
Forces	Dynamic [N]	
F _x ᵃ)	4000	
F _y	2500	
F _z	5000	6000
-F _z	3000	4000
Moments	Dynamic [Nm]	
M _x	350	500
M _y	700 (900)	1000 (1300)
M _z	500 (900)	1000 (1300)

ᵃ) Maximum value (see diagram "F_x-v-Diagram")
Data in brackets refer to long carriage plate (500)

For mechanical linear drives with roller guide, the static load rating "C_{stat}" (page TL 11) applies for static loads.

with toothed belt drive and roller guide (ARS) or double linear guide (ASS)

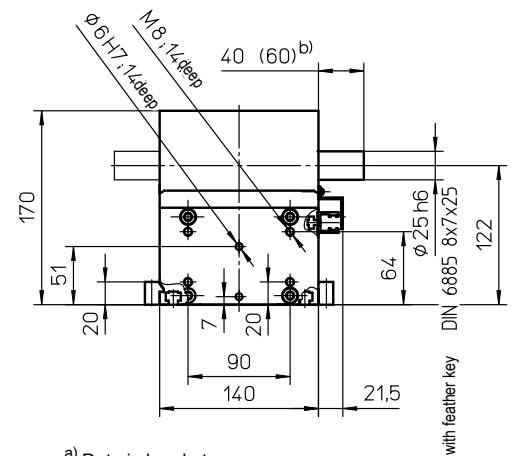
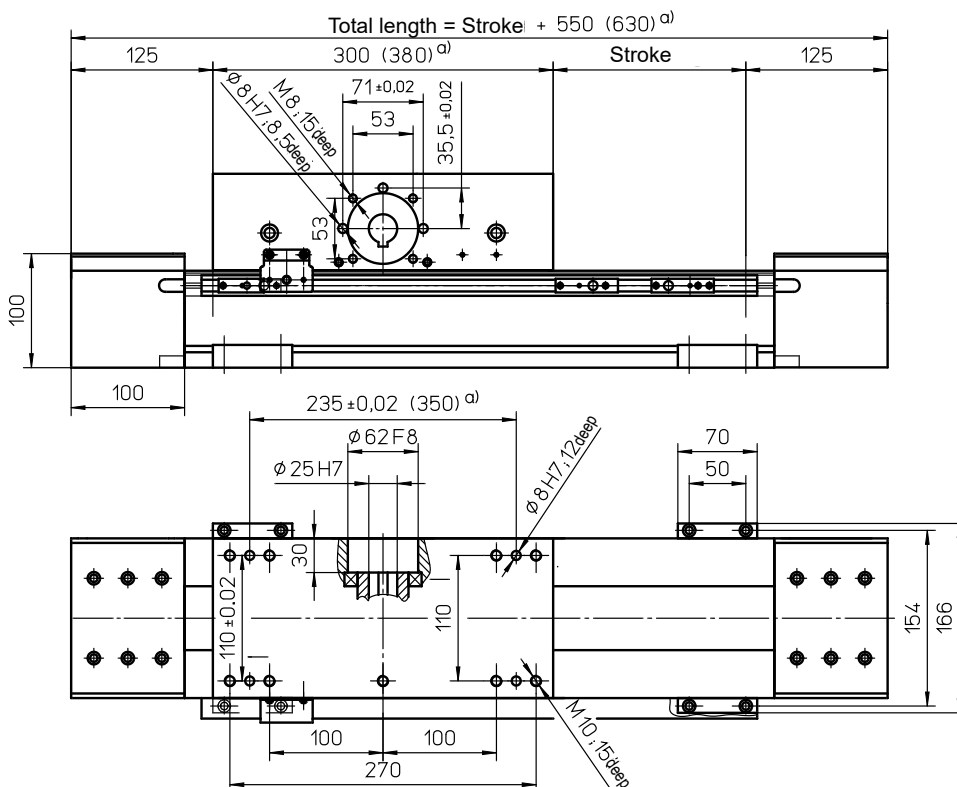

a) Data in brackets refer to long carriage

b) Data in brackets refer to version GX

Mounting elements see page B50

Weights	ARS	ASS
Basic length without stroke:	28.00 kg	30.00 kg
100 mm stroke:	1.20 kg	1.50 kg
Carriage drive 300 mm:	10.70 kg	11.70 kg
Carriage drive 380 mm:	13.00 kg	14.00 kg

Max. total length: 8100 mm
(longer on request)

Technical Data	ARS	ASS
Max. speed:	8.00 m/s	5.00 m/s
Max. acceleration:	60 m/s ²	
Repeat accuracy:	± 0.08 mm	
Idle torque:	3.50 Nm	
Moment of inertia:	3.50 · 10 ⁻² kgm ²	3.70 · 10 ⁻² kgm ²
Drive element:	Toothed belt 50 AT10-E	
Stroke per revolution:	240 mm	

Forces and moments

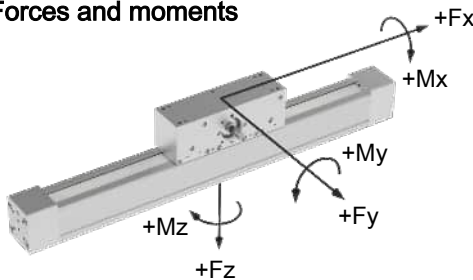

	ARS	ASS
Forces	Dynamic [N]	
F_x ^{d)}	2500	
F_y	2500	
F_z	5000	6000
-F_z	3000	4000
Moments	Dynamic [Nm]	
M_x	350	500
M_y	500 (700)	1000 (1300)
M_z	350 (500)	1000 (1300)

^{d)} Maximum value (see diagram "F_x-v-Diagram")
Data in brackets refer to long carriage (380)

F_x - v - Diagram

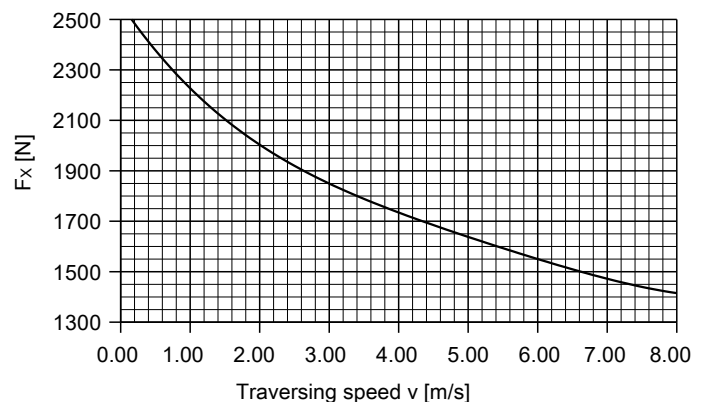

For mechanical linear drives with roller guide, the static load rating "C_{stat}" (page TL11) applies for static loads.

with toothed belt drive and double linear guide (ZSS)

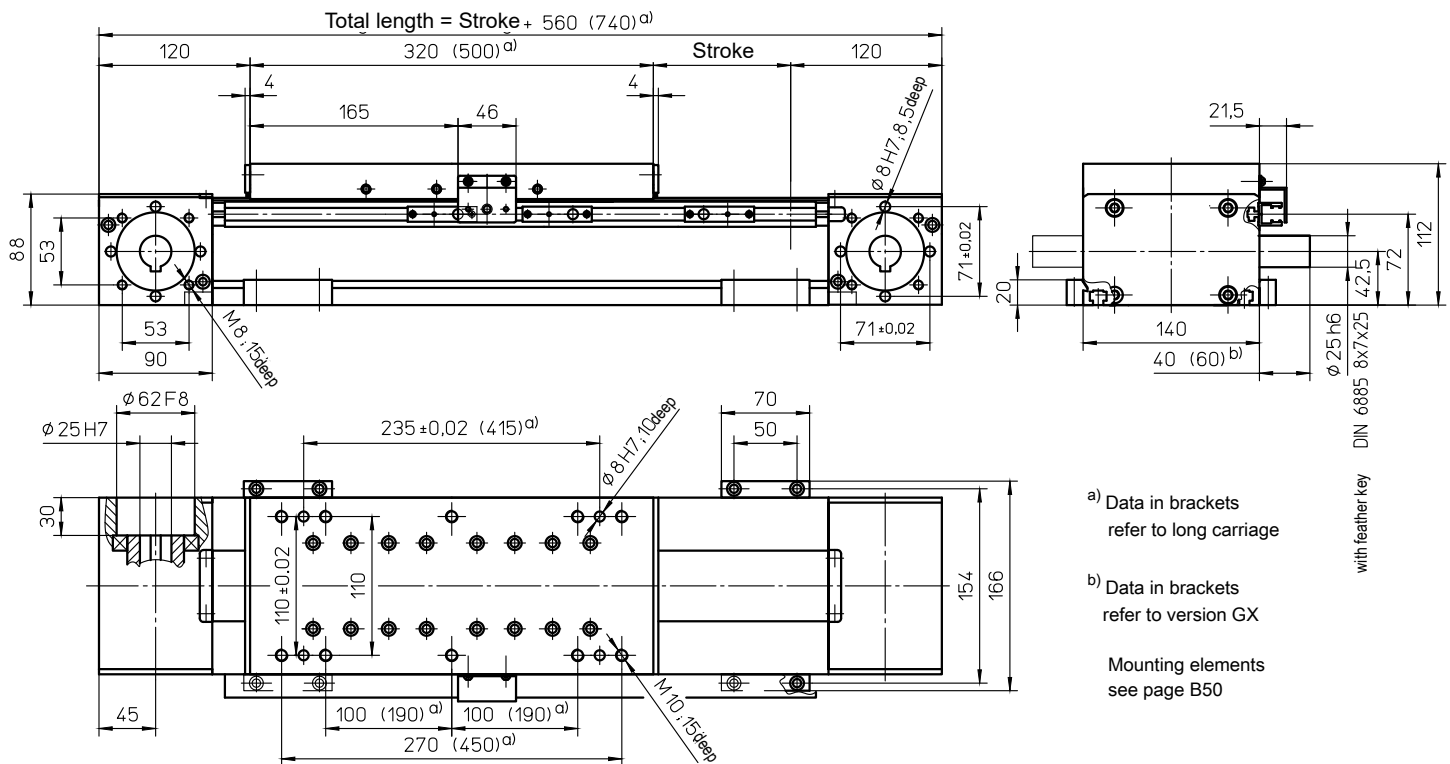

a) Data in brackets refer to long carriage

b) Data in brackets refer to version GX

Mounting elements see page B50

Weights

ZSS

Basic length without stroke:	15.00 kg
100 mm stroke:	1.70 kg
Entire carriage 320 mm:	7.50 kg
Entire carriage 500 mm:	11.70 kg
Max. total length: (longer on request)	8100 mm

Technical Data

ZSS

Max. speed:	5.00 m/s
Max. acceleration:	60 m/s ²
Repeat accuracy:	± 0.08 mm
Idle torque:	3.50 Nm
Moment of inertia:	2.00 · 10 ⁻² kgm ²
Drive element:	Toothed belt 50 AT10-E
Stroke per revolution:	220 mm

Forces and moments

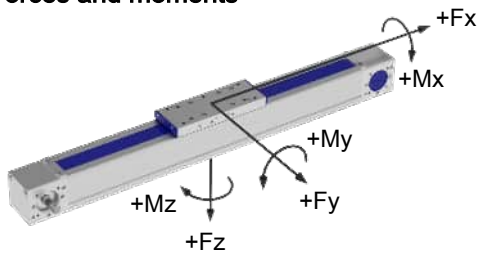

ZSS	
Forces	Dynamic [N]
$F_x^{d)}$	4000
F_y	3200
F_z	7500
$-F_z$	5000
Moments	Dynamic [Nm]
M_x	600
M_y	1200 (1700)
M_z	1200 (1700)

d) Maximum value (see diagram "Fx-v-Diagram")
Data in brackets refer to long carriage plate (500)

Fx - v - Diagram

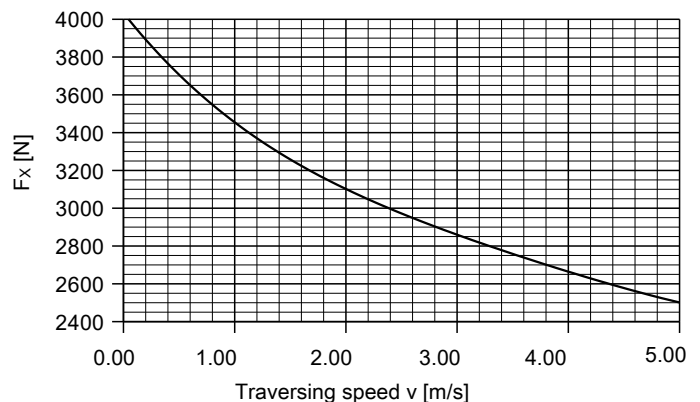

with toothed belt drive and double linear guide (ASS)

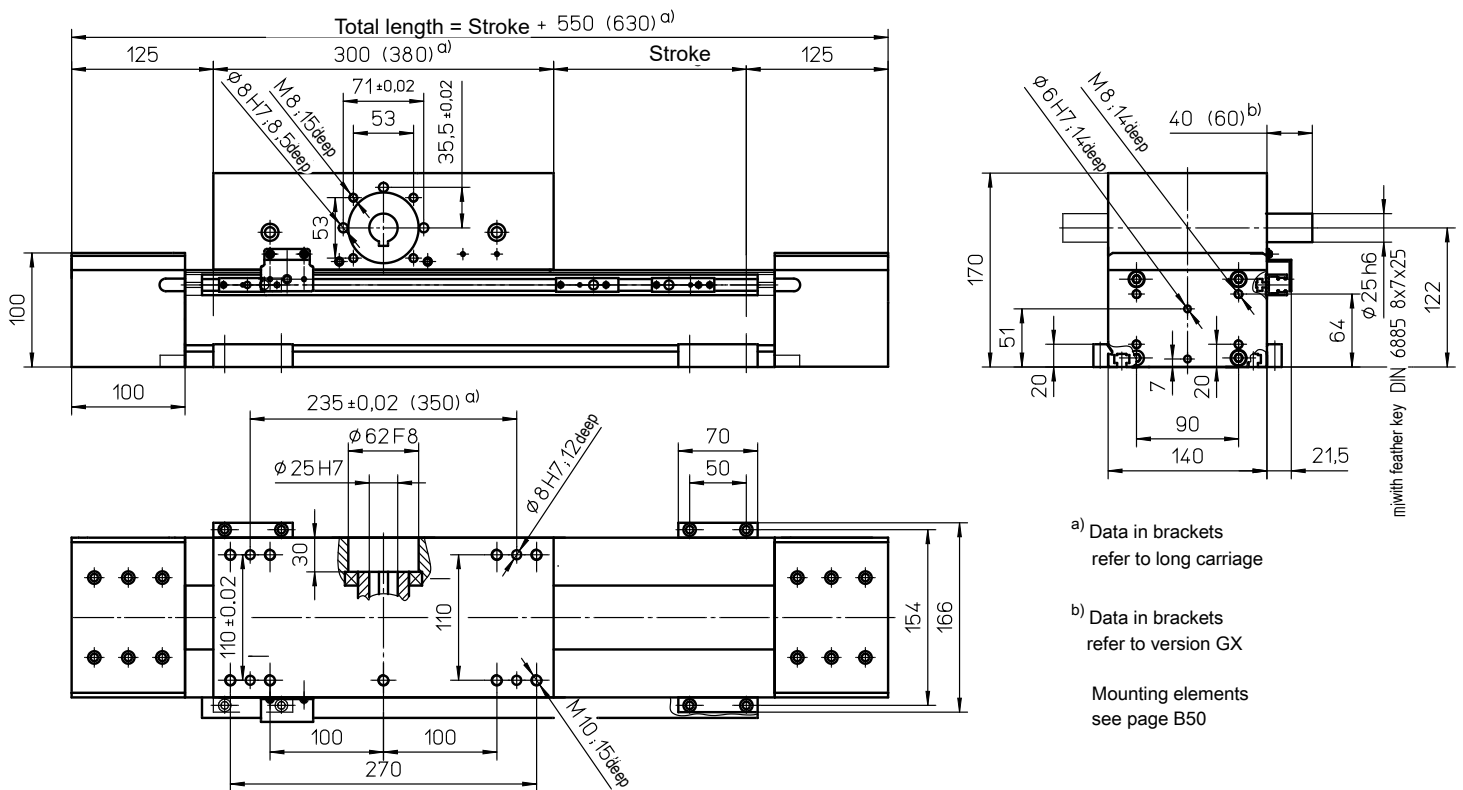

a) Data in brackets refer to long carriage
 b) Data in brackets refer to version GX
 Mounting elements see page B50

Weights ASS

Basic length without stroke:	30.00 kg
100 mm stroke:	1.50 kg
Carriage drive 300 mm:	11.70 kg
Carriage drive 380 mm:	14.00 kg
Max. total length: (longer on request)	8100 mm

Technical Data ASS

Max. speed:	5.00 m/s
Max. acceleration:	60 m/s ²
Repeat accuracy:	± 0.08 mm
Idle torque:	3.50 Nm
Moment of inertia:	3.70 · 10 ⁻² kgm ²
Drive element:	Toothed belt 50 AT10-E
Stroke per revolution:	240 mm

Forces and moments

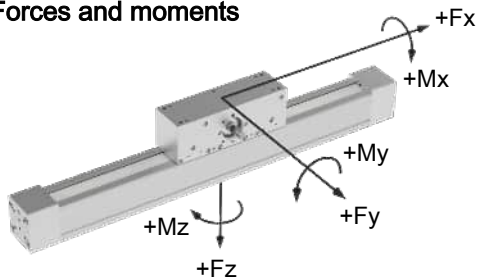

ASS	
Forces	Dynamic [N]
F_x^{d)}	2500
F_y	3200
F_z	7500
-F_z	5000
Moments	Dynamic [Nm]
M_x	600
M_y	1200 (1600)
M_z	1200 (1600)

^{d)} Maximum value (see diagram "F_x-v-Diagram")
 Data in brackets refer to long carriage plate (380)

F_x - v - Diagram

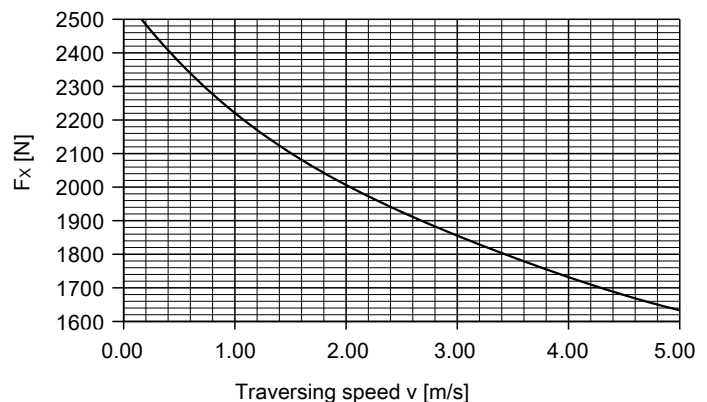

with ball screw (KGT) and double linear guide (SSS)

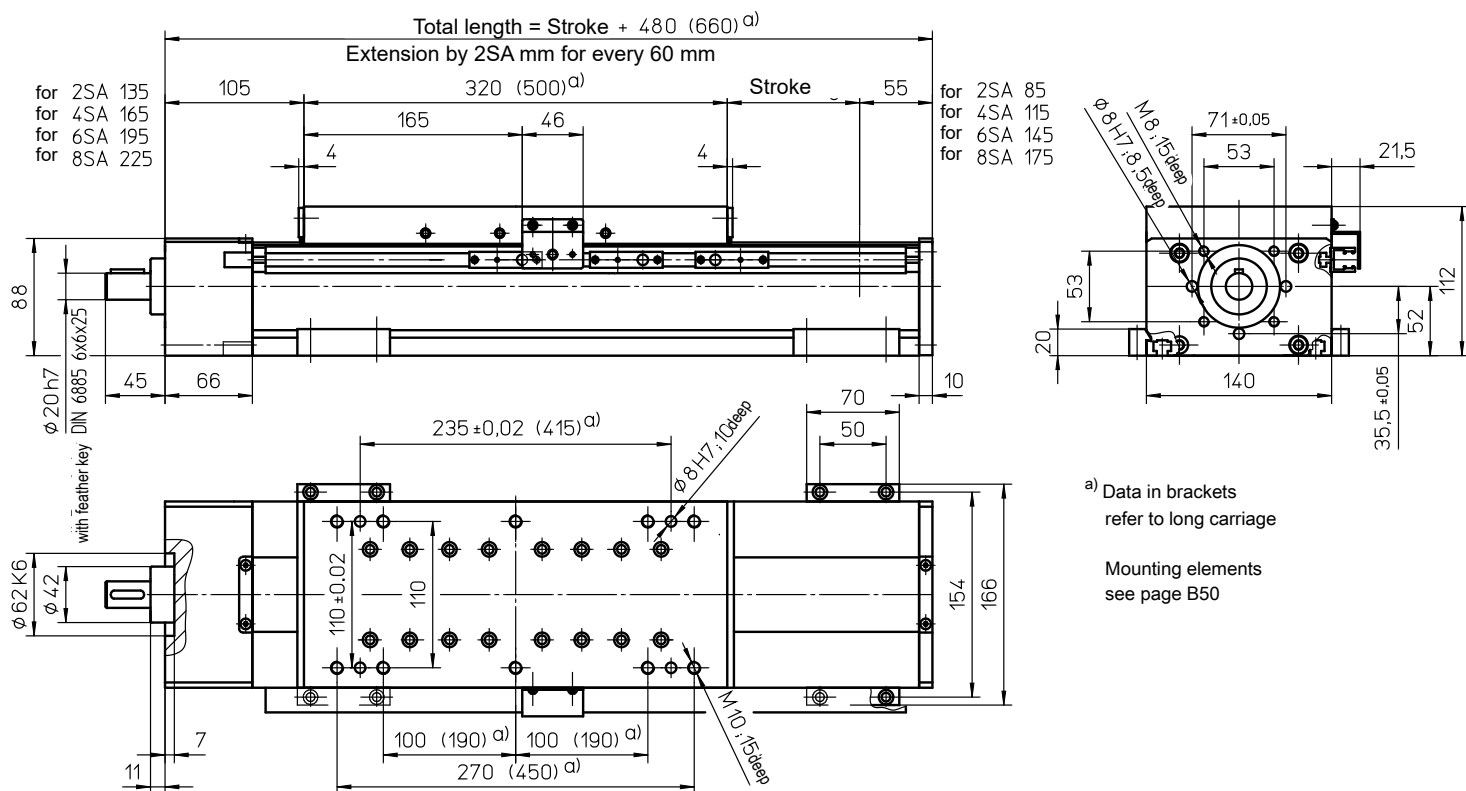

a) Data in brackets refer to long carriage

Mounting elements see page B50

Weights

	SSS
Basic length without stroke:	15.00 kg
100 mm stroke:	1.90 kg
Entire carriage 320 mm:	7.00 kg
Entire carriage 500 mm:	10.90 kg
(longer on request) Max. total length:	5600 mm

Technical Data

	SSS
Max. speed:	2.50 m/s
Max. acceleration:	20 m/s ²
Repeat accuracy:	± 0.03 mm (KGT)
Idle torque:	1.50 Nm

Forces and moments

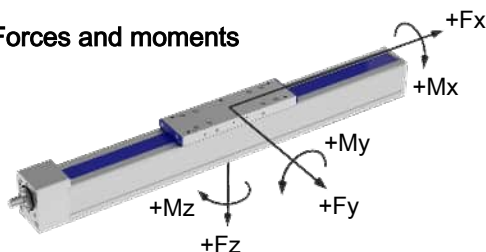

	SSS
Forces	Dynamic [N]
F_x	6000
F_y	3200
F_z	7500
-F_z	5000
Moments	Dynamic [Nm]
M_x	600
M_y	1200 (1700)
M_z	1200 (1700)

Data in brackets refer to long carriage plate (500)

Drive element

	KGT
Max. rotation speed:	3000 min ⁻¹
Diameter:	25 mm
Pitch:	5 / 10 / 25 / 50 mm
Moment of inertia:	2.25 · 10 ⁻⁴ kgm ² /m

Spindle support (SA)

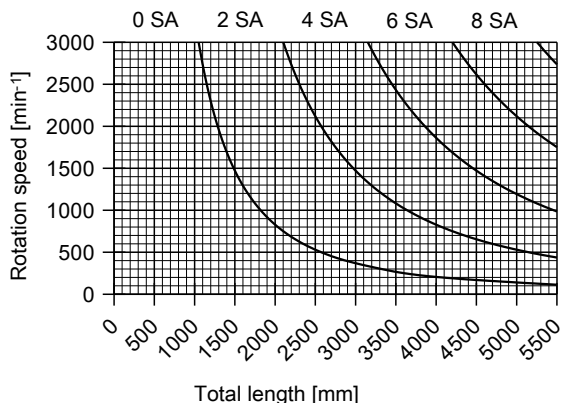

Special design: Spindle support with damping ring (extension of total length: 10 mm for every 2 SA)
Version with double nut ("MM") only available with long carriage (500) and not with pitch "50".

with toothed belt drive and rail guide (ZSS)

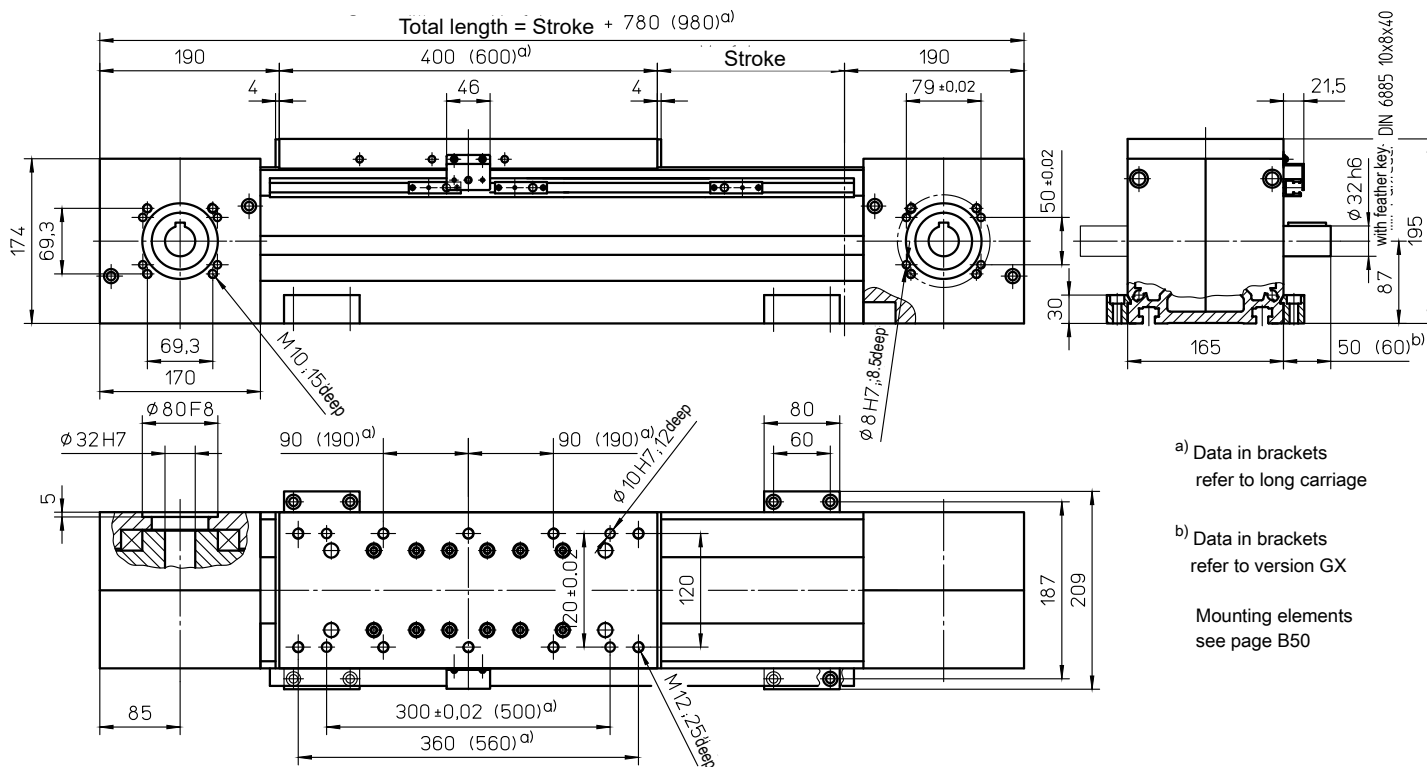

a) Data in brackets refer to long carriage

b) Data in brackets refer to version GX

Mounting elements see page B50

Weights

ZSS

Basic length without stroke:	38.40 kg
100 mm stroke:	3.00 kg
Entire carriage 400 mm:	11.90 kg
Entire carriage 600 mm:	17.90 kg
Max. total length: (longer on request)	7700 mm

Technical Data

ZSS

Max. speed:	5.00 m/s
Max. acceleration:	60 m/s ²
Repeat accuracy:	± 0.08 mm
Idle torque:	12.00 Nm
Moment of inertia:	8.50 · 10 ⁻² kgm ²
Drive element:	Toothed belt 75 ATS 15
Stroke per revolution:	450 mm

Forces and moments

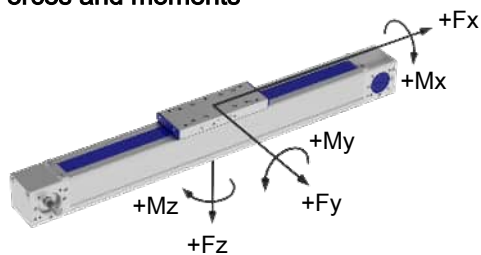

ZSS	
Forces	Dynamic [N]
F_x^{d)}	10000
F_y	5000
F_z	15000
-F_z	8000
Moments	Dynamic [Nm]
M_x	700
M_y	1400 (2000)
M_z	1100 (1500)

^{d)} Maximum value (see diagram "F_x-v-Diagram")
Data in brackets refer to long carriage plate (600)

F_x - v - Diagram

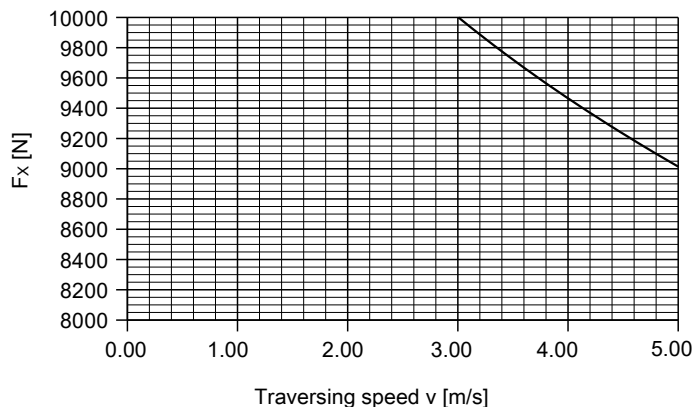

with ball screw (KGT) and rail guide (SSS)

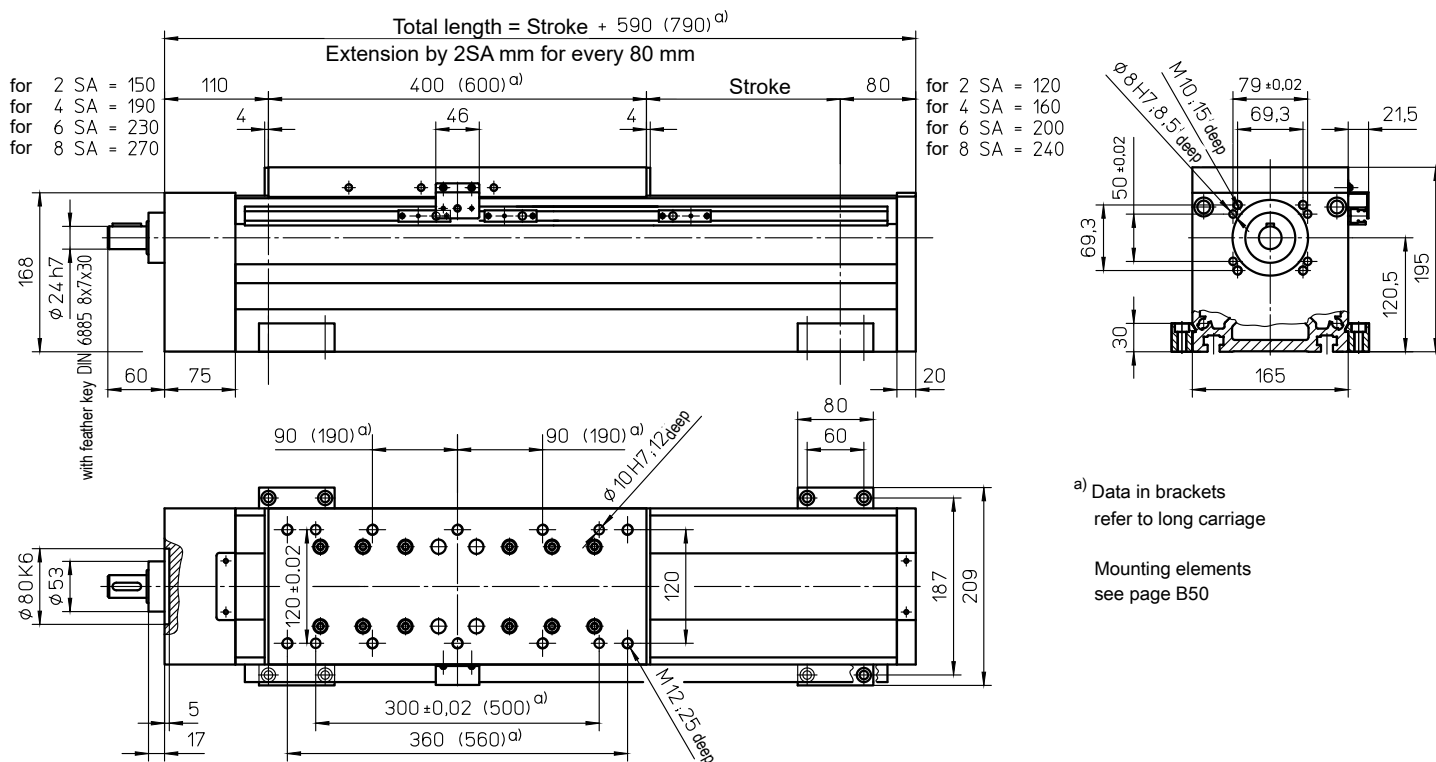

a) Data in brackets refer to long carriage

Mounting elements see page B50

Weights

	SSS
Basic length without stroke:	33.90 kg
100 mm stroke:	3.70 kg
Entire carriage 400 mm:	11.50 kg
Entire carriage 600 mm:	17.25 kg
Max. total length: (longer on request)	5600 mm

Technical Data

	SSS
Max. speed:	2.00 m/s
Max. acceleration:	20 m/s ²
Repeat accuracy:	± 0.03 mm (KGT)
Idle torque:	3.00 Nm

Forces and moments

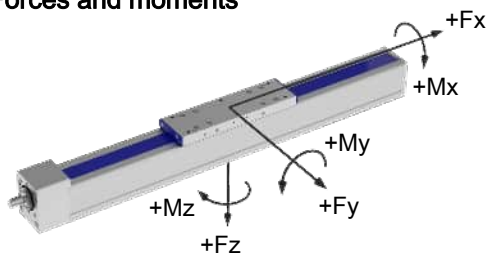

	SSS
Forces	Dynamic [N]
F_x	18000
F_y	5000
F_z	15000
-F_z	8000
Moments	Dynamic [Nm]
M_x	800
M_y	1800 (3000)
M_z	1400 (2000)

Data in brackets refer to long carriage plate (600)

Drive element

	KGT
Max. rotation speed:	3000 min ⁻¹
Diameter:	40 mm
Pitch:	5 / 10 / 20 / 40 mm
Moment of inertia:	1.34 · 10 ⁻³ kgm ² /m

Spindle support (SA)

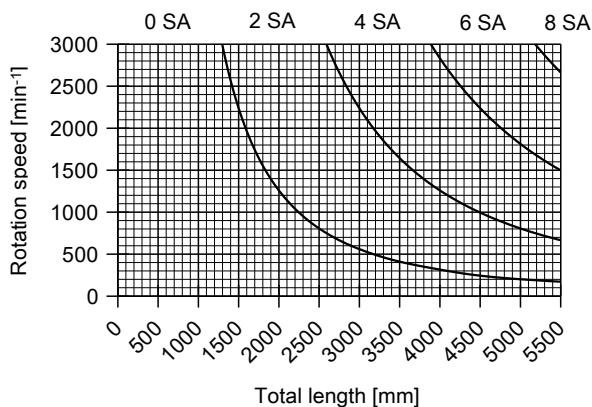

Special design: Spindle support with damping ring (extension of total length: 10 mm for every 2 SA)
Version with double nut ("MM") is only possible with long carriage plate (600) and not with pitch "5".

with ball screw (KGT) and sliding guide (SGV)

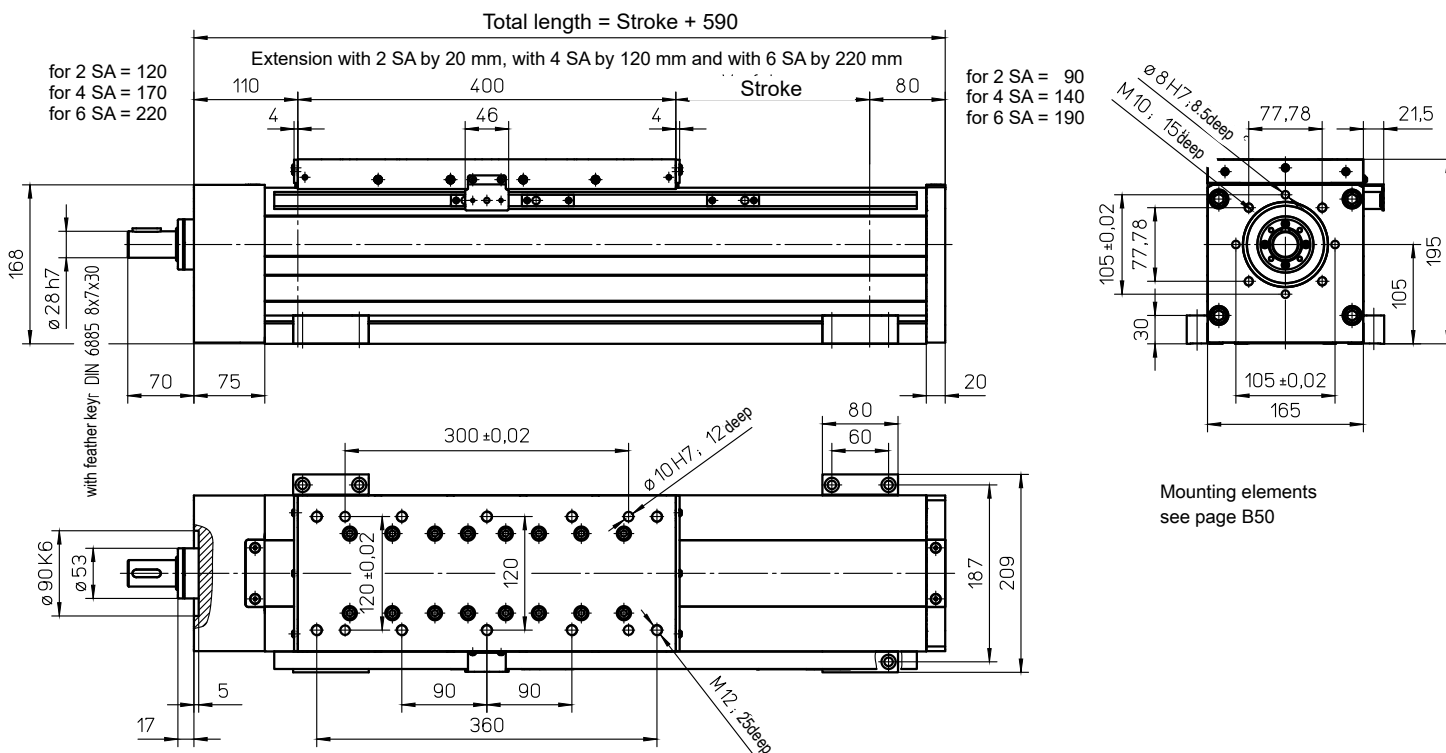

Weights

	SGV
Basic length without stroke:	33.00 kg
100 mm stroke:	3.30 kg
Entire carriage 400 mm:	10.50 kg
Max. total length: (longer on request)	5600 mm

Technical Data

	SGV
Max. speed:	2.00 m/s
Max. acceleration:	20 m/s ²
Repeat accuracy:	± 0.03 mm (KGT)
Idle torque:	3.00 Nm

Forces and moments

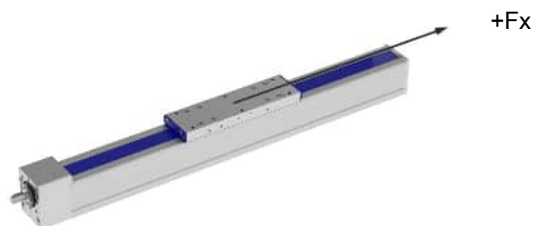

	SGV
Forces	Dynamic [N]
F_x	18000
F_y	-
F_z	-
-F_z	-
Moments	Dynamic [Nm]
M_x	-
M_y	-
M_z	-

"-" => Must have an external guide.

Drive element

	KGT
Max. rotation speed:	3000 min ⁻¹
Diameter:	40 mm
Pitch:	5 / 10 / 20 / 40 mm
Moment of inertia:	1.34 · 10 ⁻³ kgm ² /m

Spindle support (SA)

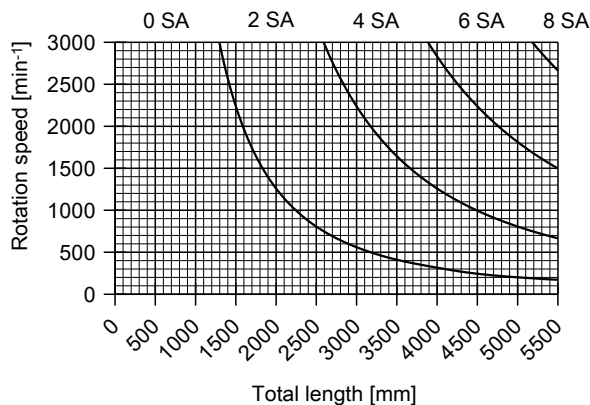

Special design: Spindle support with damping ring (extension of total length: 10 mm for every 2 SA)
Version with double nut ("MM") not possible.

with ball screw (KGT) and sliding guide (SGV)

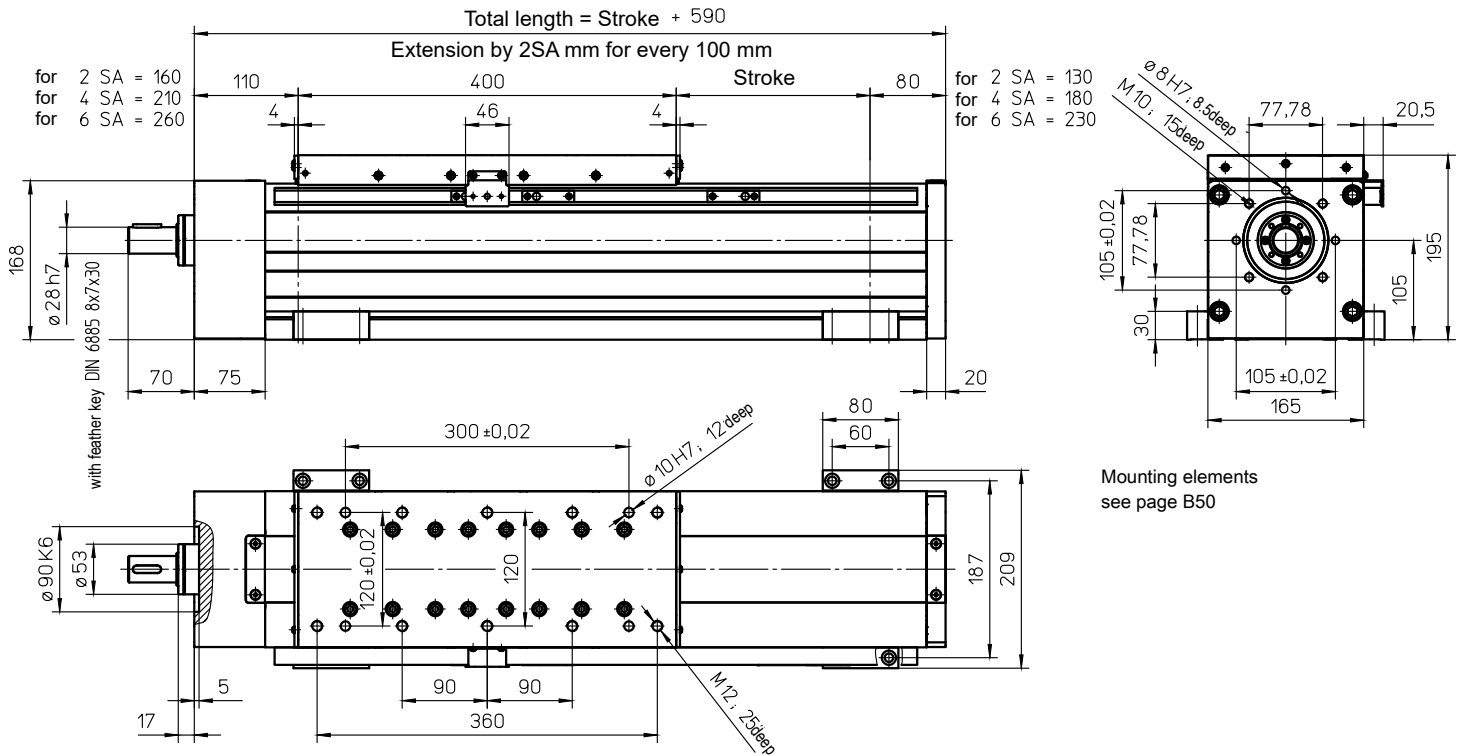

Weights

	SGV
Basic length without stroke:	34.00 kg
100 mm stroke:	3.75 kg
Entire carriage 400 mm:	10.80 kg
Max. total length: (longer on request)	5600 mm

Technical Data

	SGV
Max. total speed:	1.00 m/s
Max. acceleration:	20 m/s ²
Repeat accuracy:	± 0.03 mm (KGT)
Idle torque:	3.20 Nm

Forces and moments

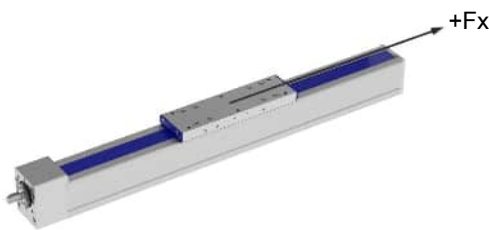

	SGV
Forces	Dynamic [N]
F_x	25000
F_y	-
F_z	-
$-F_z$	-
Moments	Dynamic [Nm]
M_x	-
M_y	-
M_z	-

"-" => Must have an external guide.

Max. rotation speed:	3000 min ⁻¹
Diameter:	50 mm
Pitch:	10 / 20 mm
Moment of inertia:	$3.45 \cdot 10^{-3}$ kgm ² /m

Spindle support (SA)

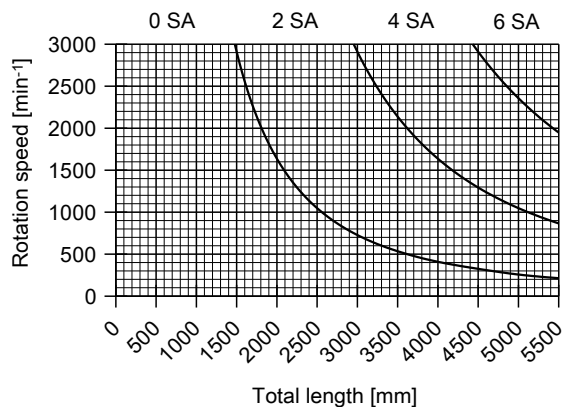

Special design: Spindle support with damping ring (extension of total length: 10 mm for every 2 SA)

with ball screw (KGT) and rail guide (SSF)

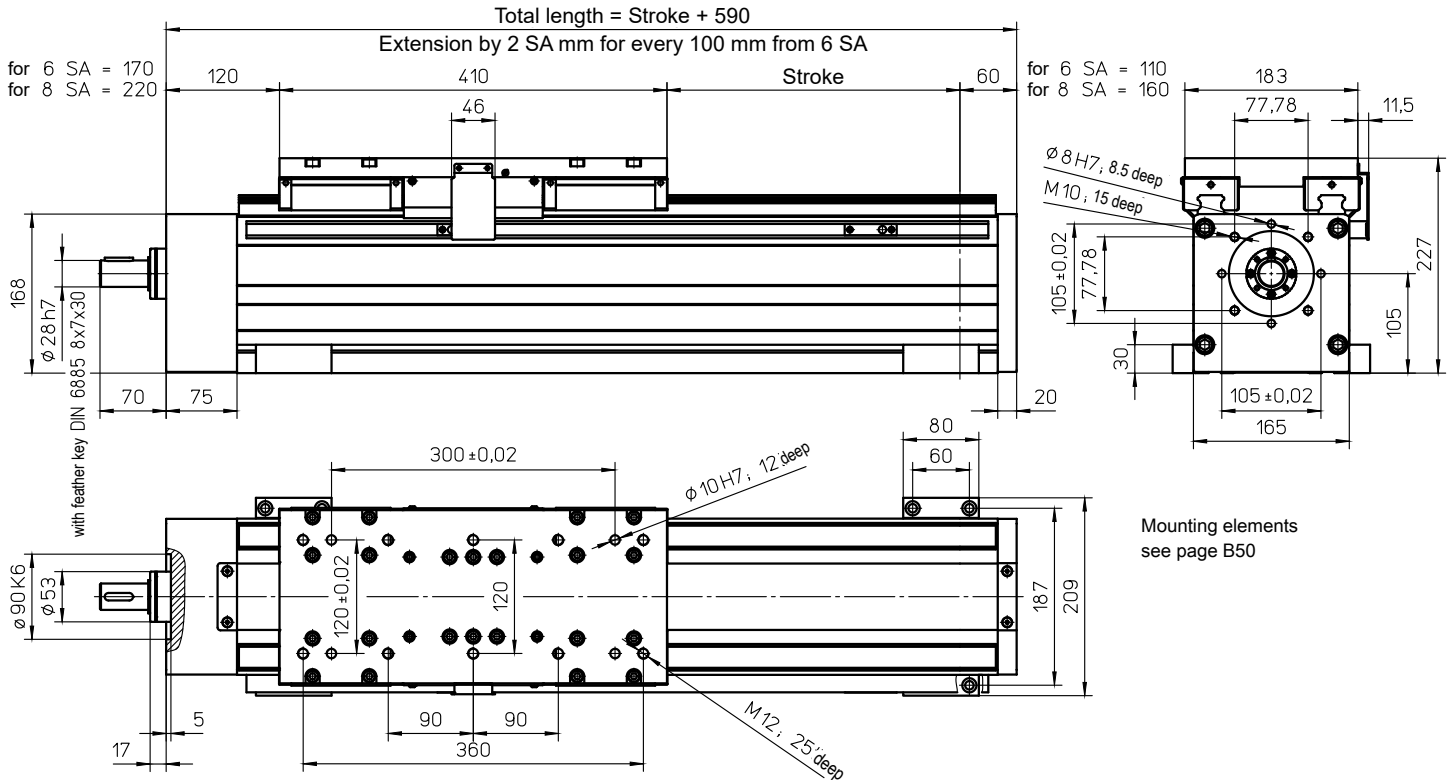

Weights

SSF

Basic length without stroke:	38.90 kg
100 mm stroke:	4.40 kg
Entire carriage 410 mm:	25.20 kg
Max. total length:	5600 mm
(longer on request)	

Technical Data

SSF

Max. total speed:	1.00 m/s
Max. acceleration:	20 m/s ²
Repeat accuracy:	± 0.03 mm (KGT)
Idle torque:	3.20 Nm

Forces and Moments

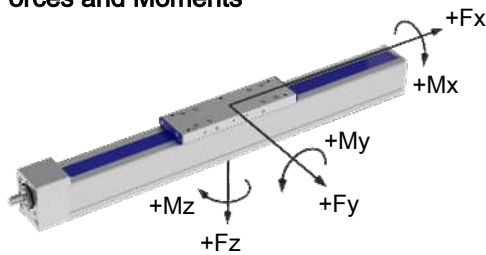

SSF	
Forces	Dynamic [N]
F_x	25000
F_y	5000
F_z	15000
-F_z	8000
Moments	Dynamic [Nm]
M_x	800
M_y	1800
M_z	1400

Drive element

KGT

Max. rotation speed:	3000 min ⁻¹
Diameter:	50 mm
Pitch:	10 / 20 mm
Moment of inertia:	3.45 · 10 ⁻³ kgm ² /m

Spindle support (SA)

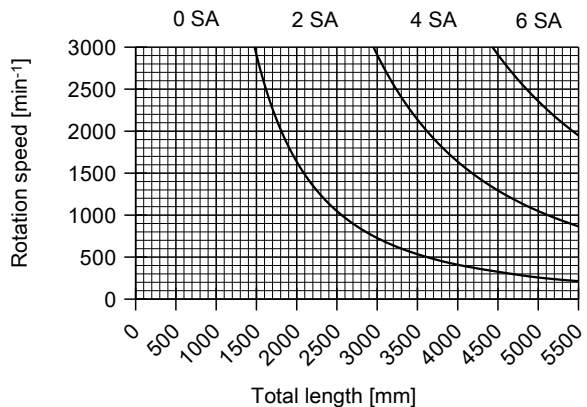

Special design: Spindle support with damping ring (from 4SA: extension of total length: 10 mm for every 2 SA)

with toothed belt drive and double linear guide (ZSS)

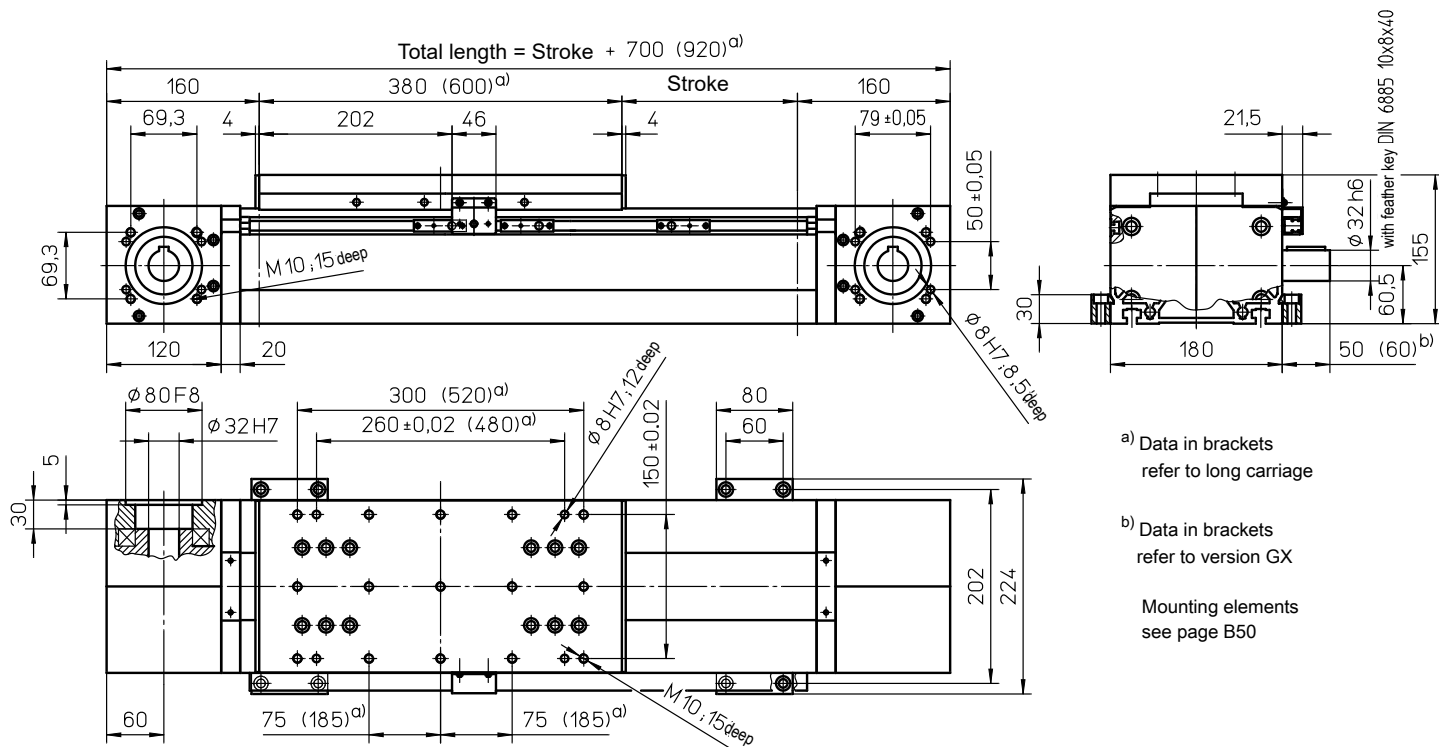

a) Data in brackets refer to long carriage

b) Data in brackets refer to version GX

Mounting elements see page B50

Weights

ZSS

Basic length without stroke:	37.70 kg
100 mm stroke:	2.40 kg
Entire carriage 380 mm:	11.20 kg
Entire carriage 600 mm:	15.70 kg
Max. total length: (longer on request)	6200 mm

Technical Data

ZSS

Max. speed:	5.00 m/s
Max. acceleration:	60 m/s ²
Repeat accuracy:	± 0.08 mm
Idle torque:	8.00 Nm
Moment of inertia:	5.60 · 10 ⁻² kgm ²
Drive element:	Toothed belt 75 AT10
Stroke per revolution:	320 mm

Forces and moments

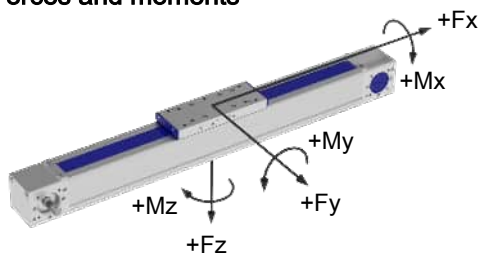

ZSS	
Forces	Dynamic [N]
F_x^{d)}	6000
F_y	6000
F_z	12000
-F_z	6000
Moments	Dynamic [Nm]
M_x	1500
M_y	3000 (4000)
M_z	1500 (2000)

^{d)} Maximum value (see diagram "F_x-v-Diagram")
Data in brackets refer to long carriage plate (600)

F_x - v - Diagram

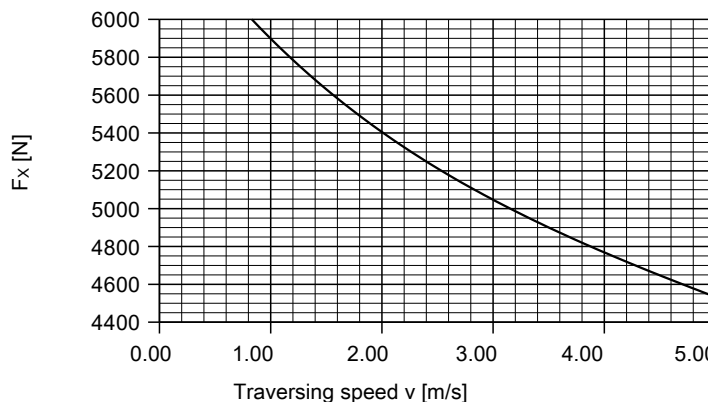

with toothed belt drive and double linear guide (ASS)

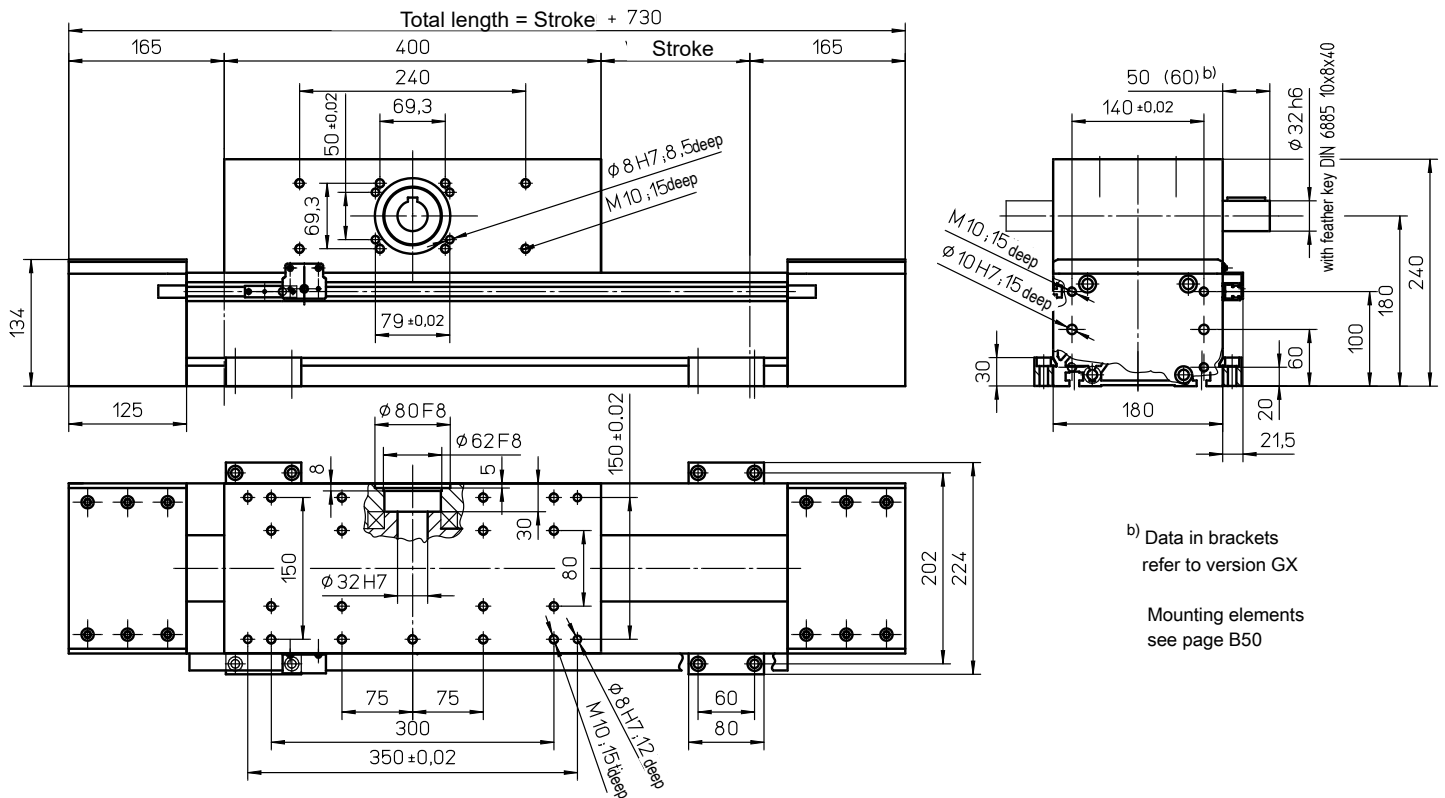

Weights ASS

Basic length without stroke:	48.90 kg
100 mm stroke:	2.80 kg
Carriage drive 400 mm:	25.60 kg
Max. total length: (longer on request)	6200 mm

Technical Data ASS

Max. speed:	5.00 m/s
Max. acceleration:	60 m/s ²
Repeat accuracy:	± 0.08 mm
Idle torque:	8.00 Nm
Moment of inertia:	6.20 · 10 ⁻² kgm ²
Drive element:	Toothed belt 75 AT10
Stroke per revolution:	320 mm

Forces and moments

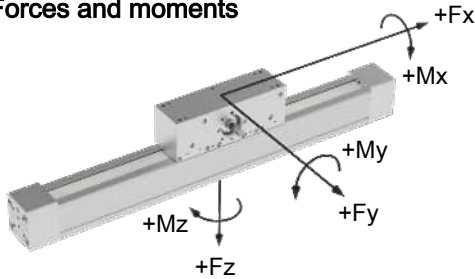

ASS	
Forces	Dynamic [N]
F_x^{d)}	3500
F_y	6000
F_z	12000
-F_z	6000
Moments	Dynamic [Nm]
M_x	1500
M_y	3000
M_z	1500

^{d)} Maximum value (see diagram "F_x-v-Diagram")

F_x - v - Diagram

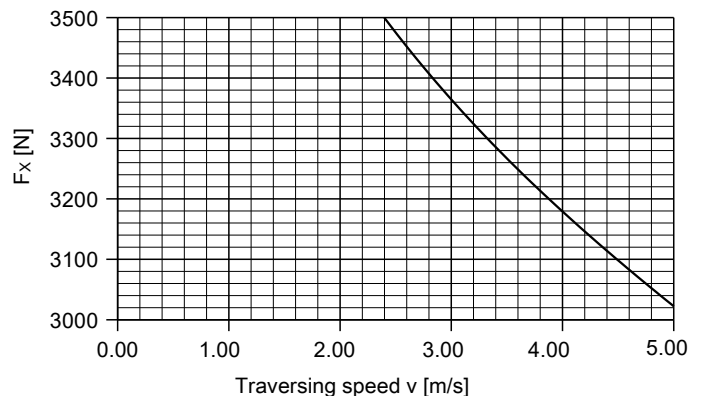

with ball screw (KGT) and double linear guide (SSS)

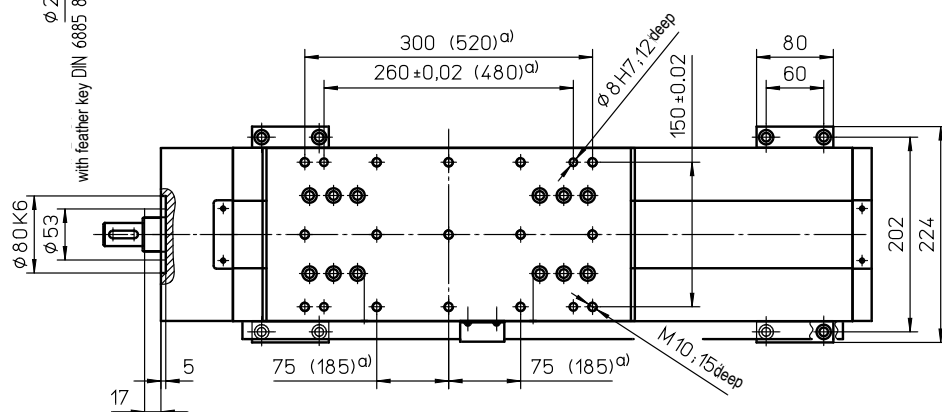
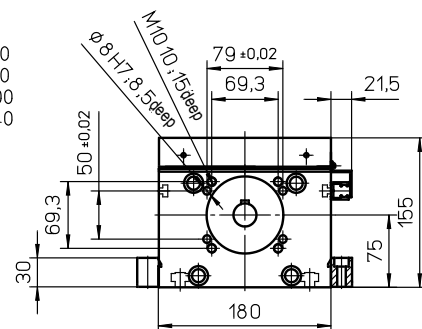
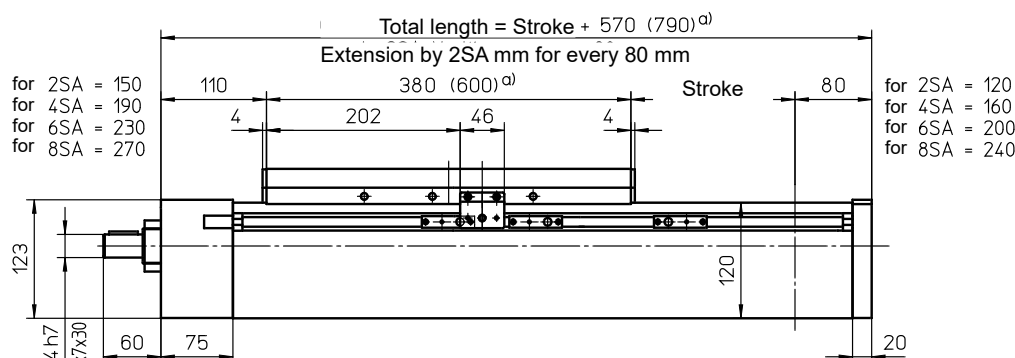

^{a)} Data in brackets refer to long carriage

Mounting elements see page B50

Weights

	SSS
Basic length without stroke:	33.50 kg
100 mm stroke:	2.80 kg
Entire carriage 380 mm:	10.80 kg
Entire carriage 600 mm:	15.50 kg
Max. total length: (longer on request)	5600 mm

Technical Data

	SSS
Max. speed:	3.00 m/s
Max. acceleration:	20 m/s ²
Repeat accuracy:	± 0.03 mm (KGT)
Idle torque:	2.50 Nm

Forces and moments

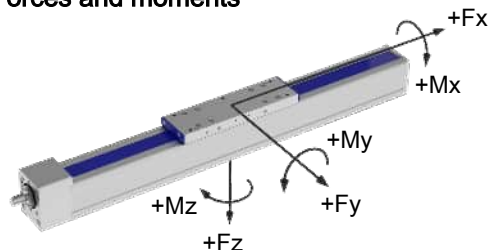

	SSS
Forces	Dynamic [N]
F_x	12000 *
F_y	6000
F_z	12000
-F_z	6000
Moments	Dynamic [Nm]
M_x	1500
M_y	3000 (4000)
M_z	1500 (2000)

Data in brackets refer to long carriage plate (600)

* for KGT 3240 and 3260: 8000 N

Special design: Spindle support with damping ring (extension of total length: 10 mm for every 2 SA)

Drive element

	KGT
Max. rotation speed:	3000 min ⁻¹
Diameter:	32 mm
Pitch:	5 / 10 / 20 / 40 / 60 mm
Moment of inertia:	6.39 · 10 ⁻⁴ kgm ² /m

Spindle support (SA)

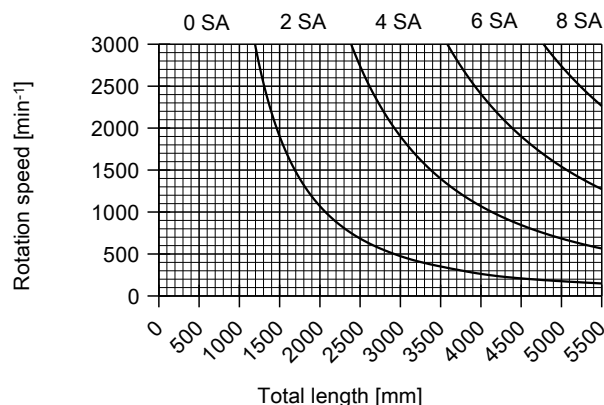

with toothed belt drive and double linear guide (ZSS)

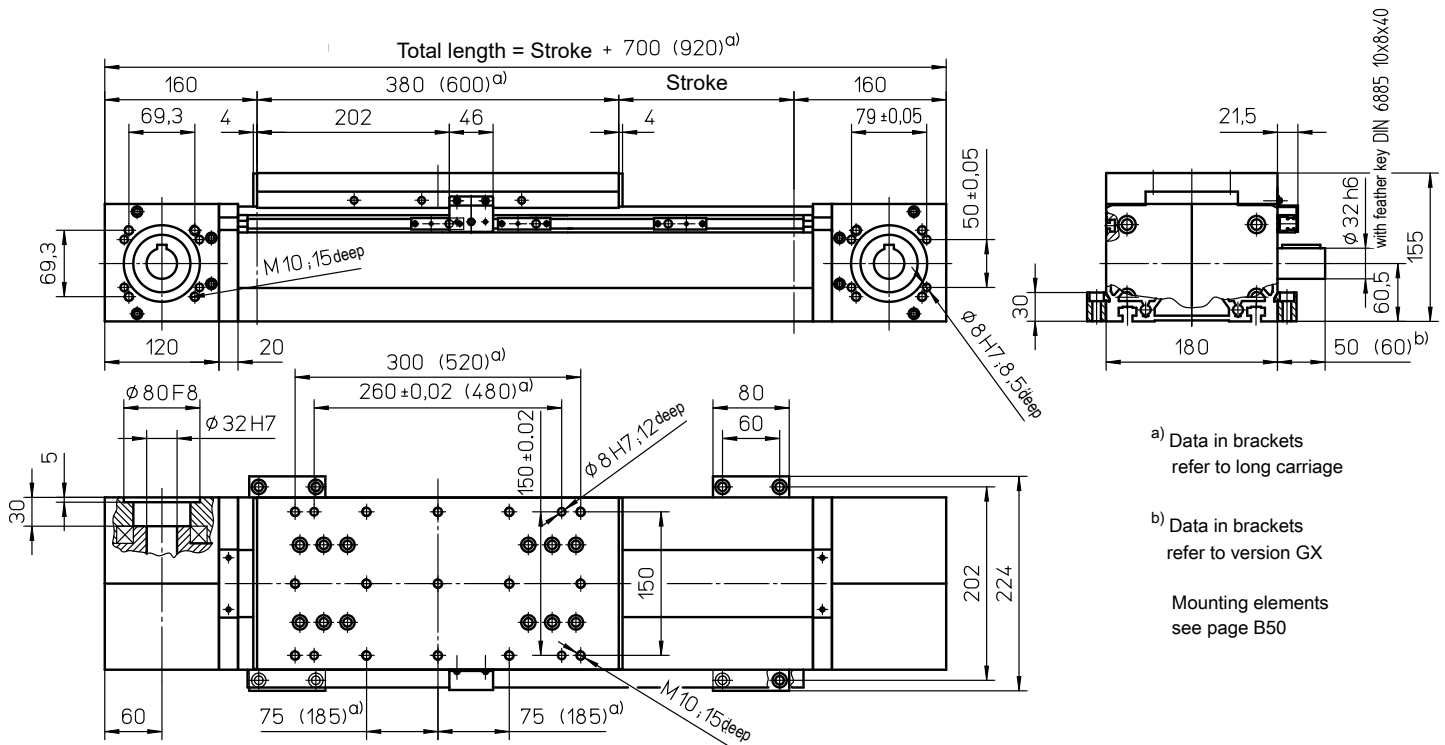

Weights ZSS

Basic length without stroke:	39.70 kg
100 mm stroke:	2.60 kg
Entire carriage 380 mm:	14.65 kg
Entire carriage 600 mm:	15.75 kg
Max. total length: (longer on request)	6200 mm

Technical Data ZSS

Max. speed:	5.00 m/s
Max. acceleration:	60 m/s ²
Repeat accuracy:	$\pm 0.08 \text{ mm}$
Idle torque:	8.00 Nm
Moment of inertia:	$4.65 \cdot 10^{-2} \text{ kgm}^2$
Drive element:	Toothed belt 75 AT10
Stroke per revolution:	320 mm

Forces and moments

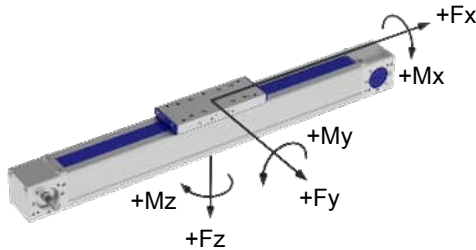

Fx - v - Diagram

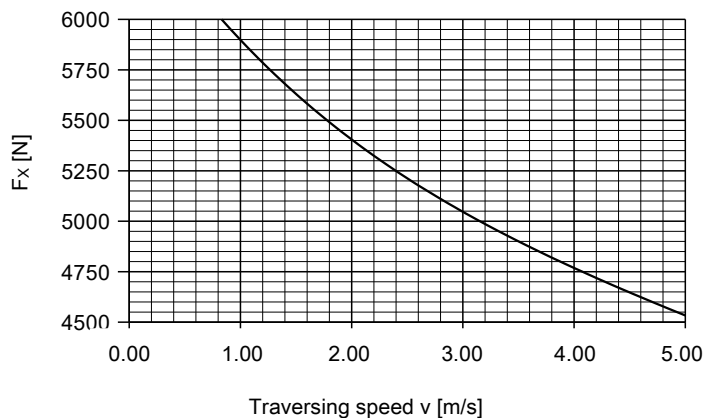

ZSS	
Forces	Dynamic [N]
F_x^d	6000
F_y	8000
F_z	15000
$-F_z$	8000
Moments	Dynamic [Nm]
M_x	1800
M_y	3600 (4800)
M_z	1800 (2400)

^{d)} Maximum value (see diagram "F_x-v-Diagram")
Data in brackets refer to long carriage plate (600)

with toothed belt drive and double linear guide (ASS)

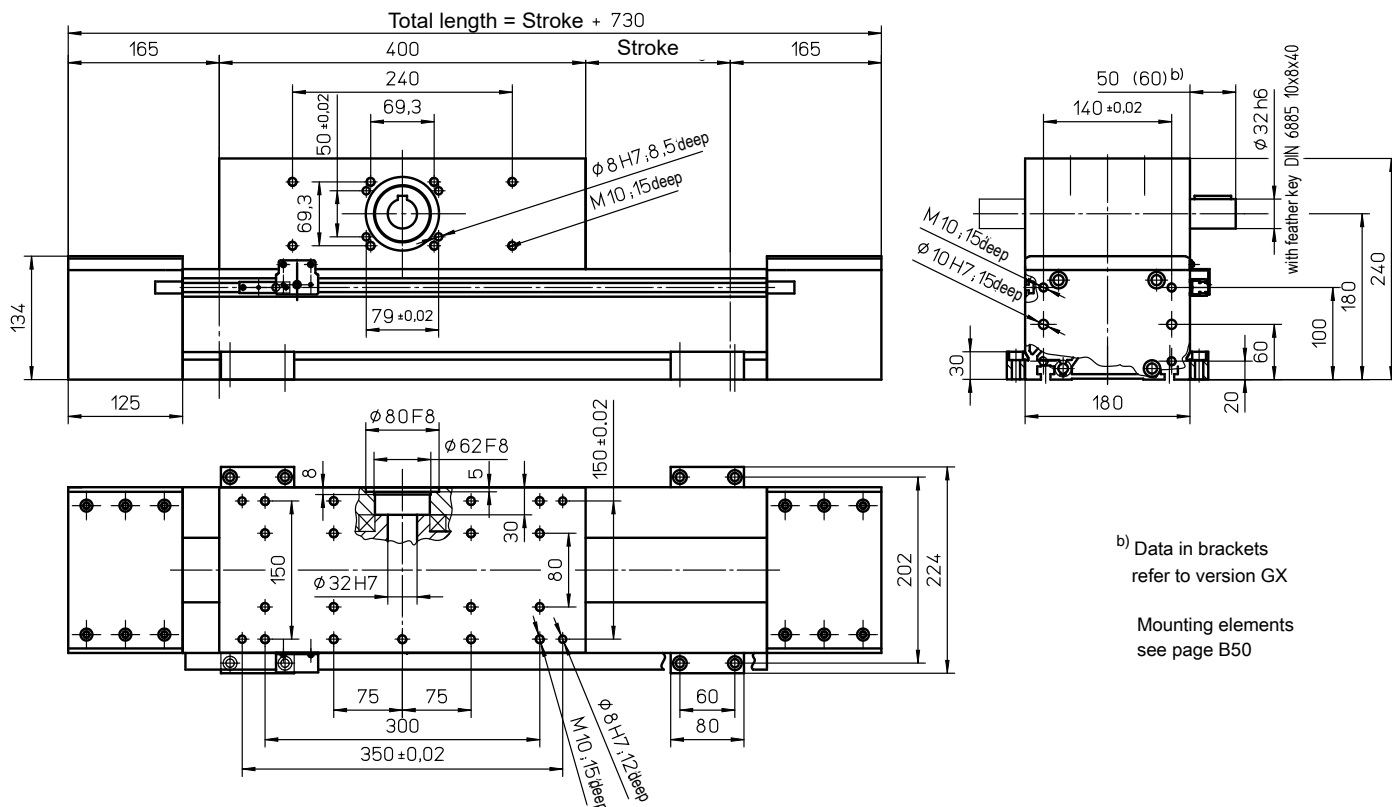

b) Data in brackets refer to version GX
Mounting elements see page B50

Weights ASS

Basic length without stroke:	51.50 kg
100 mm stroke:	3.60 kg
Carriage drive 400 mm:	27.35 kg
Max. total length: (longer on request)	6200 mm

Technical Data ASS

Max. speed:	5.00 m/s
Max. acceleration:	60 m/s ²
Repeat accuracy:	± 0.08 mm
Idle torque:	8.00 Nm
Moment of inertia:	7.75 · 10 ⁻² kgm ²
Drive element:	Toothed belt 75 AT10
Stroke per revolution:	320 mm

Forces and moments

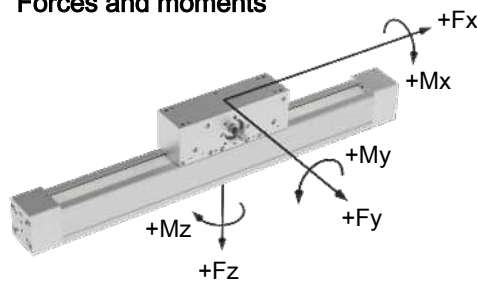

ASS	
Forces	Dynamic [N]
F_x^{d)}	3500
F_y	8000
F_z	15000
-F_z	8000
Moments	Dynamic [Nm]
M_x	1800
M_y	3600 (4800)
M_z	1800 (2400)

^{d)} Maximum value (see diagram "F_x-v-Diagram")

F_x - v - Diagram

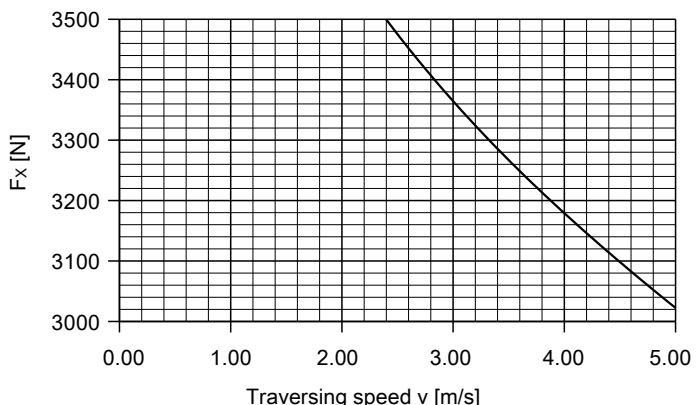

For mechanical linear drives with roller guide, the static load rating "C_{stat}" (page TL 11) applies for static loads.

with ball screw (KGT) and double linear guide (SSS)

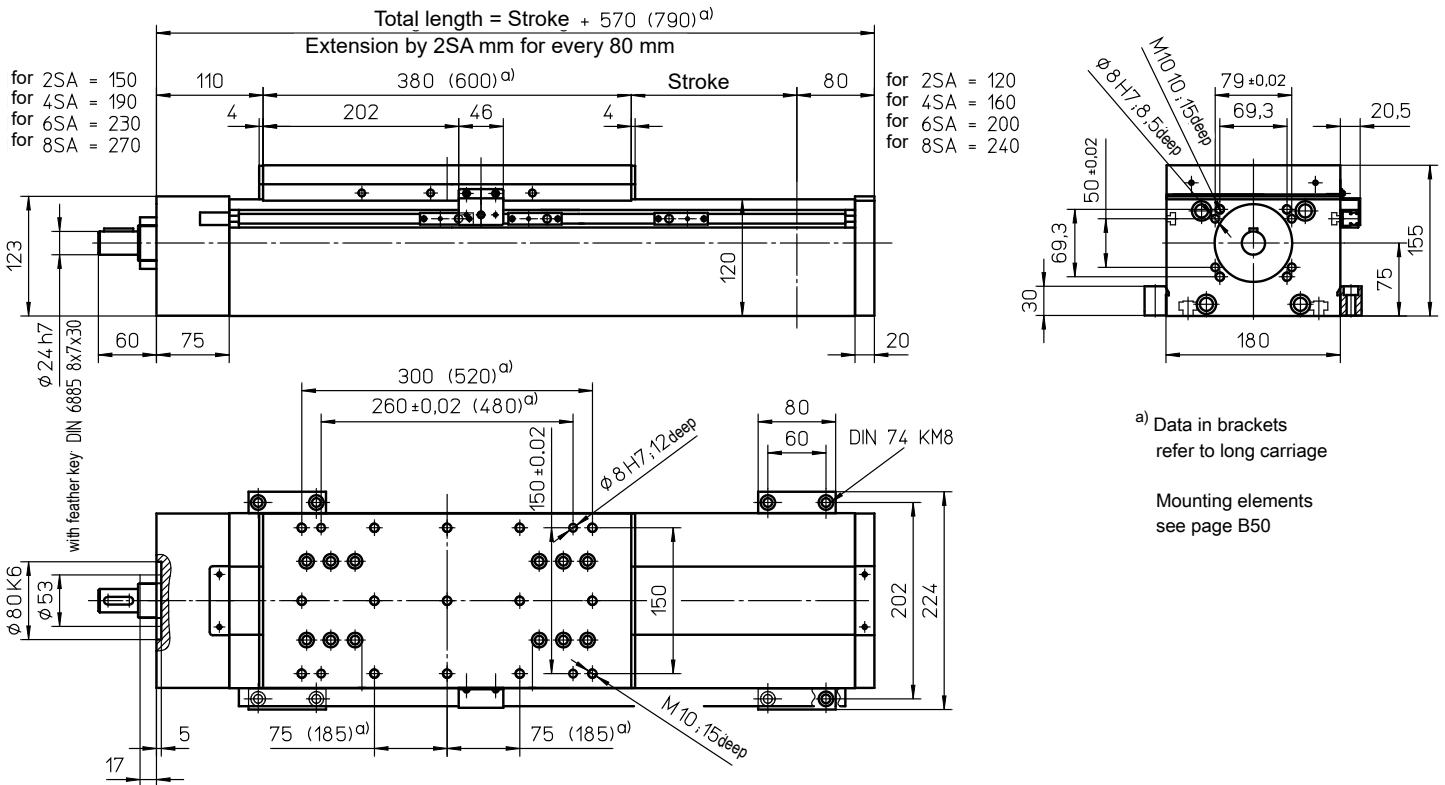

a) Data in brackets refer to long carriage

Mounting elements see page B50

Weights SSS

Basic length without stroke:	37.00 kg
100 mm stroke:	3.00 kg
Entire carriage drive 380 mm:	14.30 kg
Entire carriage drive 600 mm:	15.40 kg

Max. total length: 5600 mm
(longer on request)

Forces and moments

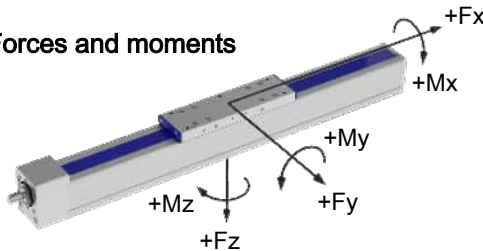

SSS	
Forces	Dynamic [N]
$F_x^{d)}$	12000 *
F_y	8000
F_z	15000
$-F_z$	8000
Moments	Dynamic [Nm]
M_x	1800
M_y	3600 (4800)
M_z	1800 (2400)

Data in brackets refer to long carriage plate (600)

* at KGT 3240 and 3260: 8000 N

Technical Data SSS

Max. total speed:	3.00 m/s
Max. acceleration:	20 m/s ²
Repeat accuracy:	± 0.03 mm (KGT)
Idle torque:	2.50 Nm

Drive element KGT

Max. rotation speed:	3000 min ⁻¹
Diameter:	32 mm
Pitch:	5 / 10 / 20 / 40 / 60 mm
Moment of inertia:	6.39 · 10 ⁻⁴ kgm ² /m

Spindle support (SA)

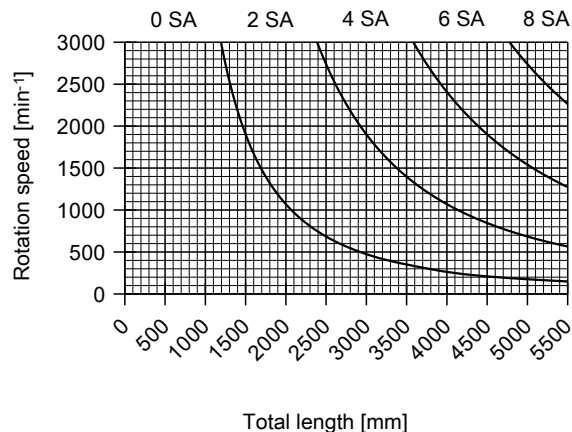

Special design: Spindle support with damping ring (extension of total length: 10 mm for every 2 SA)

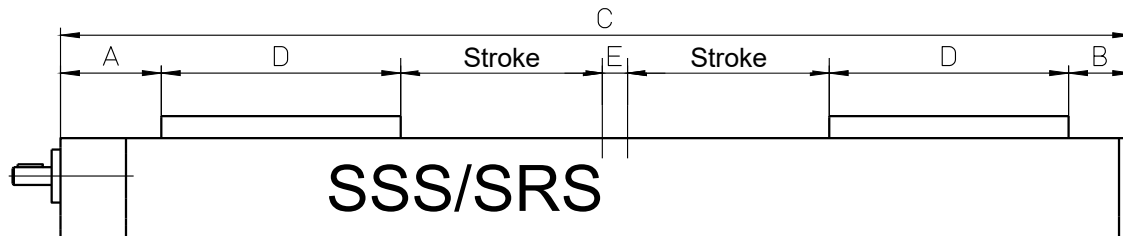

Unit size	A [mm]	B [mm]	Total length C [mm]	D [mm]	E [mm]	Screw drive ^{c)}
Beta 50-C-SRS	60	20	2 x stroke + 3800 (480) ^{a)} + E	150 (200) ^{a)}	min. 50	KGT 1205 or Tr 12x3
Beta 60-SGV Beta 60-SSS	65	35	2 x stroke + 460 (560) ^{a)} + E 120 mm extension for every 4 SA	180 (230) ^{a)}	min. 40 without SA	KGT 2005 or Tr 20x4
Beta 70-C-SRS Beta 70-C-SSS	80	50	2 x stroke + 510 (610) ^{a)} + E 80 mm extension for every 4 SA	190 (240) ^{a)}	min. 30 without SA min. 30 ^{b)} without SA	KGT 1605 or Tr 16x4
Beta 80-SRS Beta 80-SSS	105	65	2 x stroke + 590 (710) ^{a)} + E 100 mm extension for every 4 SA	210 (270) ^{a)}	min. 30 without SA min. 30 ^{b)} without SA	KGT 20025 or Tr 20x4
Beta 110-SRS Beta 110-SSS	105	55	2 x stroke + 800 (1160) ^{a)} + E 120 mm extension for every 4 SA	320 (500) ^{a)}	min. 30 without SA min. 30 without SA	KGT 2505 or Tr 24x5
Beta 120-C-SSS	105	55	2 x stroke + 800 (1160) ^{a)} + E 120 mm extension for every 4 SA	320 (500) ^{a)}	min. 40 without SA	KGT 3205 or Tr 32x6
Beta 140-C-SSS	105	55	2 x stroke + 800 (1160) ^{a)} + E 120 mm extension for every 4 SA	320 (500) ^{a)}	min. 30 without SA	KGT 2505 or Tr 24x5
Beta 165-SSS	110	55	2 x stroke + 990 (1390) ^{a)} + E 160 mm extension for every 4 SA	320 (500) ^{a)}	min. 30 without SA	KGT 405/4010 or Tr 32x6
Beta 180-C-SSS	110	55	2 x stroke + 950 (1390) ^{a)} + E 160 mm extension for every 4 SA	320 (500) ^{a)}	min. 30 without SA	KGT 3205 or Tr 32x6

For detailed measurements, see main data sheet for respective size (version).

a) Data in brackets apply to long carriage plate.

b) Value applies to guide Bosch-Rexroth. For guide THK applies value 40.

c) Load ratings for KGT see table on page TL 13

Please note that the technical data of the axes may change for right/left versions.

Individual technical advice from our sales department is therefore required depending on the application.

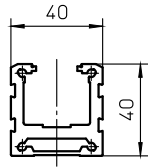

Profile Beta 40

Specific mass [kg/m]	1.72
Surface measure [mm ²]	636
Geometrical moment of inertia I _y [mm ⁴]	88914
Geometrical moment of inertia I _z [mm ⁴]	133632
Section modulus W _y [mm ³]	3762
Section modulus W _z [mm ³]	6678

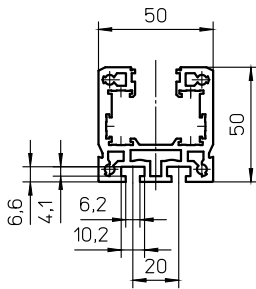

Profile Beta 50-C

Specific mass [kg/m]	2.45
Surface measure [mm ²]	907
Geometrical moment of inertia I _y [mm ⁴]	235424
Geometrical moment of inertia I _z [mm ⁴]	294804
Section modulus W _y [mm ³]	8586
Section modulus W _z [mm ³]	11792

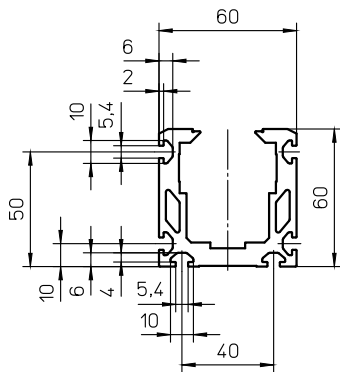

Profile Beta 60-SGV-SSS

Specific mass [kg/m]	3.35
Surface measure [mm ²]	1240
Geometrical moment of inertia I _y [mm ⁴]	474324
Geometrical moment of inertia I _z [mm ⁴]	577693
Section modulus W _y [mm ³]	13698
Section modulus W _z [mm ³]	19256

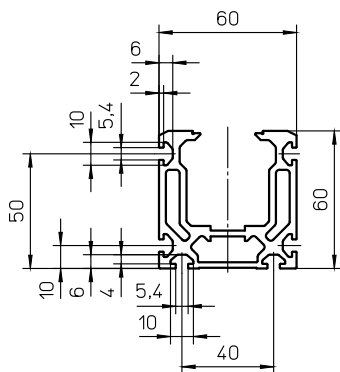

Profile Beta 60-ZSS

Specific mass [kg/m]	3.01
Surface measure [mm ²]	1114
Geometrical moment of inertia I _y [mm ⁴]	400064
Geometrical moment of inertia I _z [mm ⁴]	522090
Section modulus W _y [mm ³]	11943
Section modulus W _z [mm ³]	17403

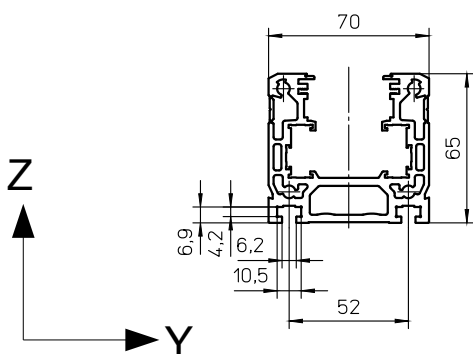

Profile Beta 70-C-ZRS-SRS

Specific mass [kg/m]	3.70
Surface measure [mm ²]	1370
Geometrical moment of inertia I _y [mm ⁴]	583502
Geometrical moment of inertia I _z [mm ⁴]	852344
Section modulus W _y [mm ³]	15714
Section modulus W _z [mm ³]	24348

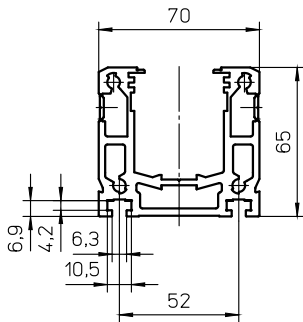

Profile Beta 70-C-ZSS-SSS

Specific mass [kg/m]	3.70
Surface measure [mm ²]	1370
Geometrical moment of inertia I _y [mm ⁴]	563227
Geometrical moment of inertia I _z [mm ⁴]	852687
Section modulus W _y [mm ³]	14783
Section modulus W _z [mm ³]	24360

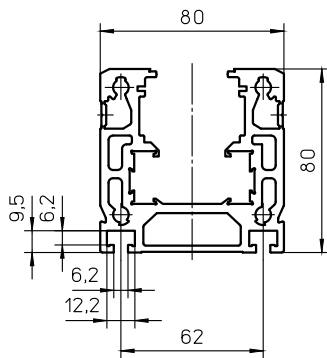

Profile Beta 80-ZRS-SRS

Specific mass [kg/m]	5.58
Surface measure [mm ²]	2066
Geometrical moment of inertia I _y [mm ⁴]	1274608
Geometrical moment of inertia I _z [mm ⁴]	1706029
Section modulus W _y [mm ³]	29631
Section modulus W _z [mm ³]	42615

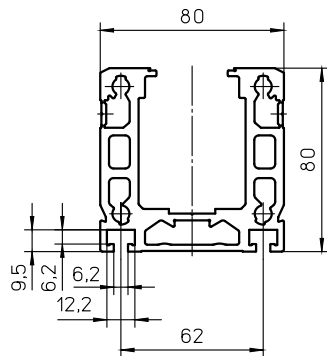

Profile Beta 80-ZSS

Specific mass [kg/m]	5.52
Surface measure [mm ²]	2044
Geometrical moment of inertia I _y [mm ⁴]	1330612
Geometrical moment of inertia I _z [mm ⁴]	1694165
Section modulus W _y [mm ³]	30499
Section modulus W _z [mm ³]	42354

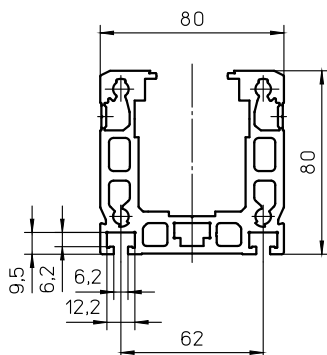

Profile Beta 80-SGV-SSS

Specific mass [kg/m]	5.55
Surface measure [mm ²]	2056
Geometrical moment of inertia I _y [mm ⁴]	1371407
Geometrical moment of inertia I _z [mm ⁴]	1677472
Section modulus W _y [mm ³]	30626
Section modulus W _z [mm ³]	41937

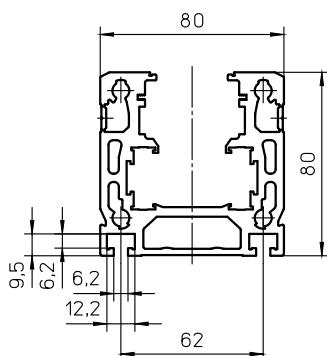

Profile Beta 80-C-ZRS

Specific mass [kg/m]	5.69
Surface measure [mm ²]	2109
Geometrical moment of inertia I _y [mm ⁴]	1304382
Geometrical moment of inertia I _z [mm ⁴]	1760119
Section modulus W _y [mm ³]	31042
Section modulus W _z [mm ³]	44002

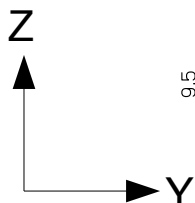

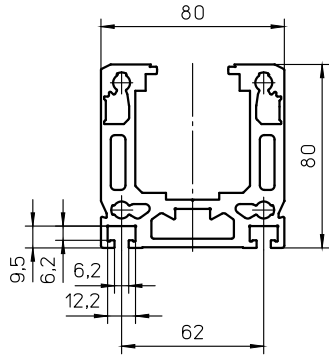

Profile Beta 80-C-ZSS

Specific mass [kg/m]	5.91
Surface measure [mm ²]	2190
Geometrical moment of inertia I _y [mm ⁴]	1374486
Geometrical moment of inertia I _z [mm ⁴]	1772461
Section modulus W _y [mm ³]	30321
Section modulus W _z [mm ³]	44309

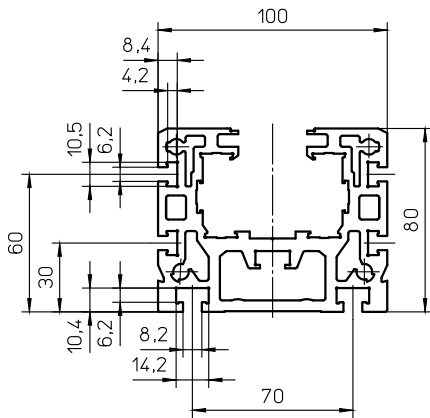

Profile Beta 100

Specific mass [kg/m]	8.03
Surface measure [mm ²]	2976
Geometrical moment of inertia I _y [mm ⁴]	1784876
Geometrical moment of inertia I _z [mm ⁴]	3588262
Section modulus W _y [mm ³]	41011
Section modulus W _z [mm ³]	71764

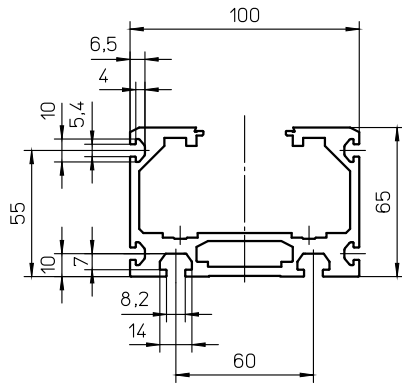

Profile Beta 100-D

Specific mass [kg/m]	4.87
Surface measure [mm ²]	1804
Geometrical moment of inertia I _y [mm ⁴]	917778
Geometrical moment of inertia I _z [mm ⁴]	2328902
Section modulus W _y [mm ³]	23868
Section modulus W _z [mm ³]	46578

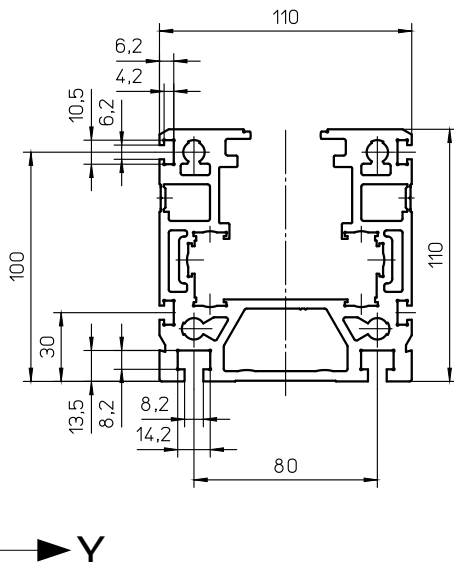

Profile Beta 110-ZRS-SRS

Specific mass [kg/m]	10.5
Surface measure [mm ²]	3890
Geometrical moment of inertia I _y [mm ⁴]	4999522
Geometrical moment of inertia I _z [mm ⁴]	6042239
Section modulus W _y [mm ³]	85583
Section modulus W _z [mm ³]	109849

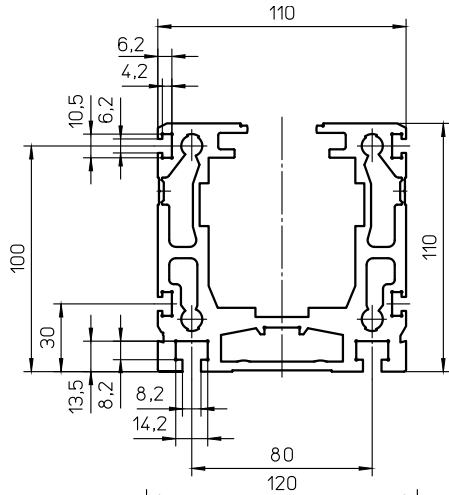

Profile Beta 110-ZSS-SSS / 110-C-SGV

Specific mass [kg/m]	10.65
Surface measure [mm ²]	3945
Geometrical moment of inertia I _y [mm ⁴]	4940967
Geometrical moment of inertia I _z [mm ⁴]	5979329
Section modulus W _y [mm ³]	79570
Section modulus W _z [mm ³]	108620

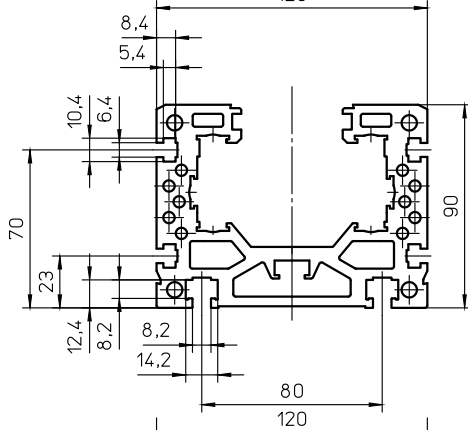

Profile Beta 120

Specific mass [kg/m]	10.44
Surface measure [mm ²]	3867
Geometrical moment of inertia I _y [mm ⁴]	3093457
Geometrical moment of inertia I _z [mm ⁴]	7081517
Section modulus W _y [mm ³]	62660
Section modulus W _z [mm ³]	118024

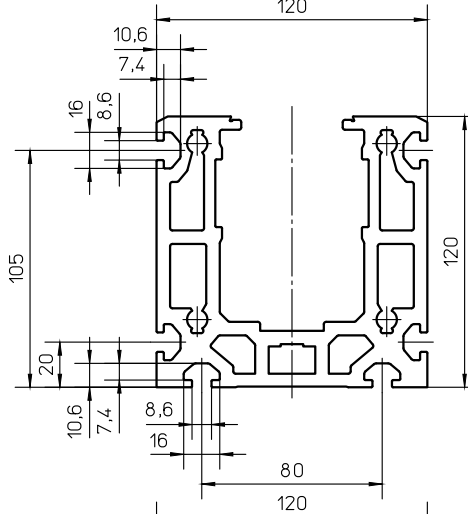

Profile Beta 120-C-SSS

Specific mass [kg/m]	13.24
Surface measure [mm ²]	4902
Geometrical moment of inertia I _y [mm ⁴]	7217779
Geometrical moment of inertia I _z [mm ⁴]	8754150
Section modulus W _y [mm ³]	104573
Section modulus W _z [mm ³]	145902

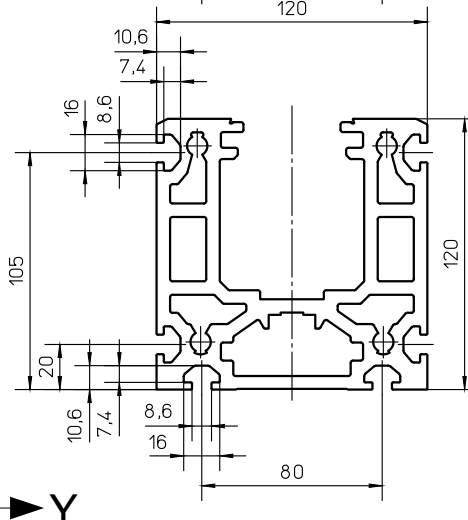

Profile Beta 120-C-ZSS

Specific mass [kg/m]	13.75
Surface measure [mm ²]	5092
Geometrical moment of inertia I _y [mm ⁴]	7115871
Geometrical moment of inertia I _z [mm ⁴]	8943087
Section modulus W _y [mm ³]	108651
Section modulus W _z [mm ³]	149051

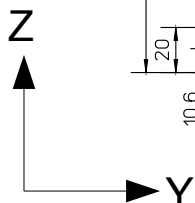

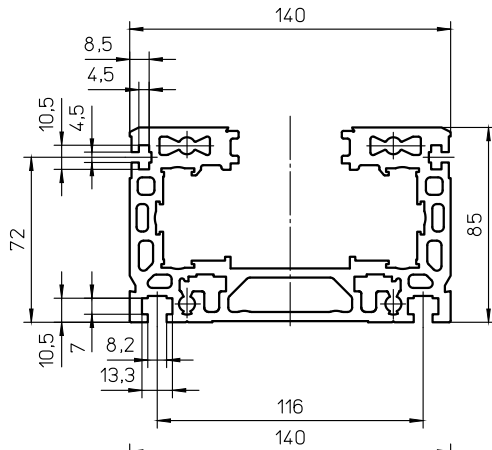

Profile Beta 140

Specific mass [kg/m]	10.14
Surface measure [mm ²]	3757
Geometrical moment of inertia I _y [mm ⁴]	3160259
Geometrical moment of inertia I _z [mm ⁴]	9121665
Section modulus W _y [mm ³]	69973
Section modulus W _z [mm ³]	130309

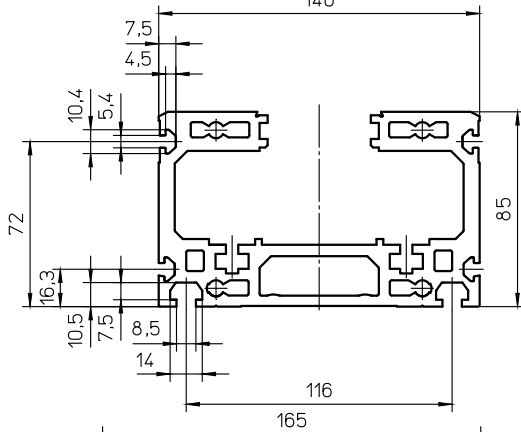

Profile Beta 140-C

Specific mass [kg/m]	10.08
Surface measure [mm ²]	3733
Geometrical moment of inertia I _y [mm ⁴]	3117373
Geometrical moment of inertia I _z [mm ⁴]	9047121
Section modulus W _y [mm ³]	66782
Section modulus W _z [mm ³]	129244

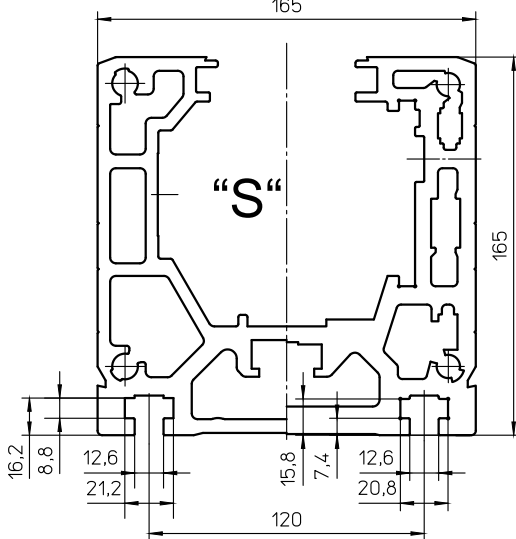

Profile Beta 165 (-C)

	"S"	
Specific mass [kg/m]	19.95	24.57
Surface measure [mm ²]	7392	9102
Geometrical moment of inertia I _y [mm ⁴]	21411115	24649421
Geometrical moment of inertia I _z [mm ⁴]	25986463	31365033
Section modulus W _y [mm ³]	228612	259364
Section modulus W _z [mm ³]	314987	380182

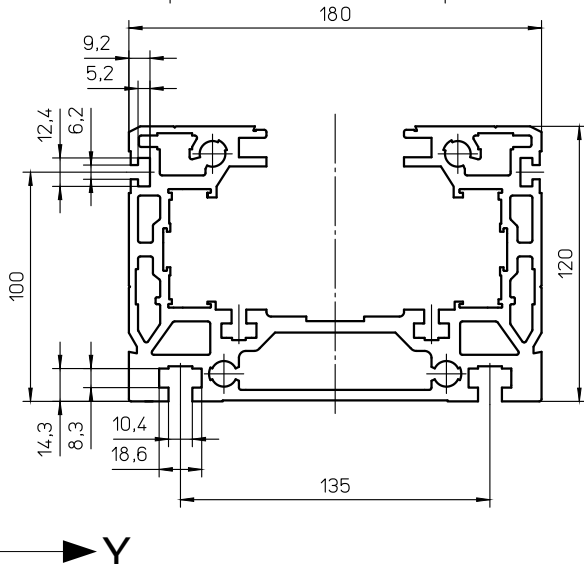

Profile Beta 180 (-C)

Specific mass [kg/m]	15.85
Surface measure [mm ²]	5870
Geometrical moment of inertia I _y [mm ⁴]	9351064
Geometrical moment of inertia I _z [mm ⁴]	24300412
Section modulus W _y [mm ³]	137690
Section modulus W _z [mm ³]	269903

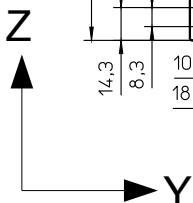

NS 1 - 7 / 11

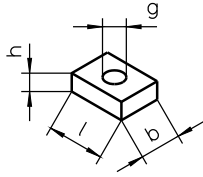

NS 4.1 / 10

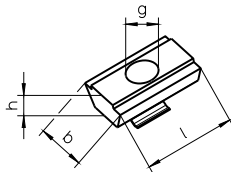

NS 8 / 9 / 12 -14

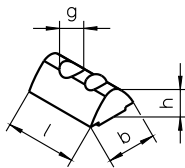

RM 2 / 4 / 6

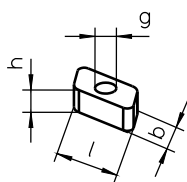

BL 1..7

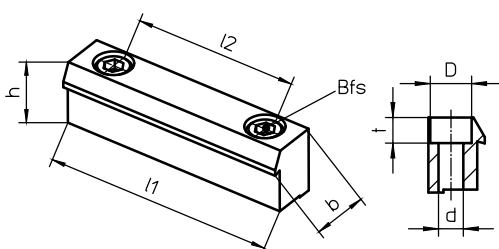

* For further information on page C..E, see catalogue page Z1.

Bfs = Mounting screw DIN 912 / ISO 4762

Lineardrive	Page*	NS	ID No.	l [mm]	b [mm]	h [mm]	g
Beta 40	C and D	7	31600	16	5.9	1.5	M3
		2	10557	16	10	4	M5
Beta 50-C	E	RM2	15370	10	6	4	M4
		8	14644	12	8	4.5	M5
Beta 60	C, D And E	9	14652	12	8	4.5	M4
		12	16280	12	8	4.5	M3
		2	10557	16	10	4	M5
Beta 70-C	E	RM2	15370	10	6	4	M4
		3	10558	20	12	5	M6
Beta 80(-C)	E	RM4	15371	13	8	6	M5
		4	10559	18	14	6	M8
Beta 100	E	4.1	16552	20	13	6	M8
		10	16499	20	13	6	M6
		RM4	15371	13	8	6	M5
	C and D	1	10556	12	10	4	M4
		2	10557	16	10	4	M5
Beta 100-D Beta 140-C	E	RM2	15370	10	6	4	M4
		4.1	16552	20	13	6	M8
	C and D	10	16499	20	13	6	M6
		8	14644	12	8	4.5	M5
		9	14652	12	8	4.5	M4
Beta 110(-C)	E	12	16280	12	8	4.5	M3
		4.1	16552	20	13	6	M8
		5	10560	20	14	8	M8
	C and D	10	16499	20	13	6	M6
		1	10556	12	10	4	M4
2		10557	16	10	4	M5	
Beta 120	E	11	18714	12	10	3.5	M4
		RM2	15370	10	6	4	M4
		4.1	16552	20	13	6	M8
	C and D	5	10560	20	14	8	M8
		10	16499	20	13	6	M6
Beta 120-C	C, D and E	1	10556	12	10	4	M4
		2	10557	16	10	4	M5
		RM2	15370	10	6	4	M4
		14	18481	22	13.5	7.6	M8
Beta 140	E	10	16499	20	13	6	M6
		13	18479	22	13.5	7.6	M4
		3	10558	20	12	5	M6
	C and D	4.1	16552	20	13	6	M8
		10	16499	20	13	6	M6
Beta 165(-C)	E	RM4	15371	13	8	6	M5
		1	10556	12	10	4	M4
		RM2	15370	10	6	4	M4
Beta 180(-C)	E	6	10561	25	18	8	M10
		RM6	15372	18	10	8	M6
	C and D	6	10561	25	18	8	M10
		RM6	15372	18	10	8	M6
Beta 180(-C)	C and D	3	10558	20	12	5	M6
		RM2	15370	10	6	4	M4

Linear drive	BL	ID No.	l1 [mm]	l2 [mm]	b [mm]	h [mm]	Bfs	D [mm]	d [mm]	t [mm]
Beta 40	1	10552	70	50	15	17,5	M6	11	6,6	6,8
Beta 50-C	1	10552	70	50	15	17,5	M6	11	6,6	6,8
Beta 60	5	14489	70	50	15	13	M6	11	6,6	6,8
Beta 70-C	1	10552	70	50	15	17,5	M6	11	6,6	6,8
Beta 80(-C)	2	10553	70	50	15	20	M6	11	6,6	6,8
Beta 100	2	10553	70	50	15	20	M6	11	6,6	6,8
Beta 100-D	5	14489	70	50	15	13	M6	11	6,6	6,8
Beta 110(-C)	2	10553	70	50	15	20	M6	11	6,6	6,8
Beta 120	1	10552	70	50	15	17,5	M6	11	6,6	6,8
Beta 120-C	7	18430	70	50	16	25	M6	11	6,6	7
Beta 140(-C)	2	10553	70	50	15	20	M6	11	6,6	6,8
Beta 165(-C)	3	10554	80	60	25	30	M8	15	9	9
Beta 180(-C)	3	10554	80	60	25	30	M8	15	9	9

Example:

Beta 80-ZRS-32 AT5-E-220-1000-1420-AK-AZ1-8RM4-1

Product

Size (version*)

Drive

Z = Toothed belt drive

0 = Without drive

A = Powered carriage

Guide system

R = Roller guide

S = Rail guide

G = Sliding guide

0 = Without guide

Model

S = Standard

Drive specifications

Width and type of toothed belt

Stroke per revolution

Stroke

Total length

Cover

AK = Cover band (Note: Total length is greater for Beta 80 and Beta 100)

Accessories

AZ1 = Drive shaft short, mounting side **C**

AZ1-GX = Drive shaft long without feather key groove, mounting side **C**

AZ2 = Drive shaft short, mounting side **D**

AZ2-GX = Drive shaft long without feather key groove, mounting side **D**

AZ6 = Drive shaft short, mounting side **C** and **D**

AZ6-GX/C = Drive shaft short, mounting side **D** and

Drive shaft long without feather key groove, mounting side **C**

AZ6-GX/D = Drive shaft short, mounting side **C** and

Drive shaft long without feather key groove, mounting side **D**

Further arrangements for drive shaft, see **page Z1**

AZx-S = Drive shaft special (x=1 side **C**, x=2 side **D**, x=6 side **C** und **D**)

EO2 / EO10 = Inductive limit switch NC with 2 m / 10 m cable fitted

ES2 / ES10 = Inductive limit switch NO with 2 m / 10 m cable fitted

EMS / EMB = Mechanical limit switch (S = Siemens, B = Balluff) fitted

BL = Mounting bracket

NS / RM = Sliding block 1 .. 14 / Rhomb nut 2 .. 6 (See Table on **page B50**)

Special design

0 = Standard

1 = Special (add specification description)

Further accessories (separate position)

MGK = Motor mounting and coupling (according to dimension sheet)

URT = Deflection belt drive (according to dimension sheet)

* e.g. Beta 80-ZSS or Beta 80-C-ZSS

Example: Beta 80-SRS-M-2020-1000-1430-2SA-2ES2-0

Product _____

Size (version*) _____

Drive _____

S = Spindle

0 = Without drive

Guide system _____

R = Roller guide

S = Rail guide

G = (Auxiliary) sliding guide

0 = Without guide

Model _____

S = Standard

V = Feed axis

F = Guide outside

Type of drive _____

M = Single nut (ball screw)

MM = Double nut (ball screw)

(TR = Trapezoidal nut - optional)

Drive specifications _____

Diameter and pitch (ball screw)

(Diameter x pitch (trapezoidal screw) - optional)

Stroke _____

Total length _____

Spindle support (SA) _____

(quantity)

Accessories _____

EO2 / EO10 = Inductive limit switch NC with 2m / 10m cable fitted

EMS / EMB = Mechanical limit switch (S = Siemens, B = Balluff) fitted

ES2 / ES10 = Inductive limit switch NO with 2m / 10m cable fitted

BL = Mounting bracket

NS / RM = Sliding block 1 .. 14 / Rhomb nut 2 .. 6 (see Table on page B50)

Special design _____

0 = Standard

1 = Special (add specification description)

Further accessories (separate position)

MGK = Motor mounting and coupling (according to dimension sheet)

URT = Deflection belt drive (according to dimension sheet)

KRG = Bevel gear directly mounted

For mounting of limit switches and lubrication points, see page **Z1**

Cover band comes as standard for screw drive

Further drives available on request:

MK or TK (= single nut made of plastic), KK (= double nut made of plastic)

* e.g. Beta 70-A-SRS or Beta 70-C-SRS

Chapter D

Compact Module

HSB-delta[®]

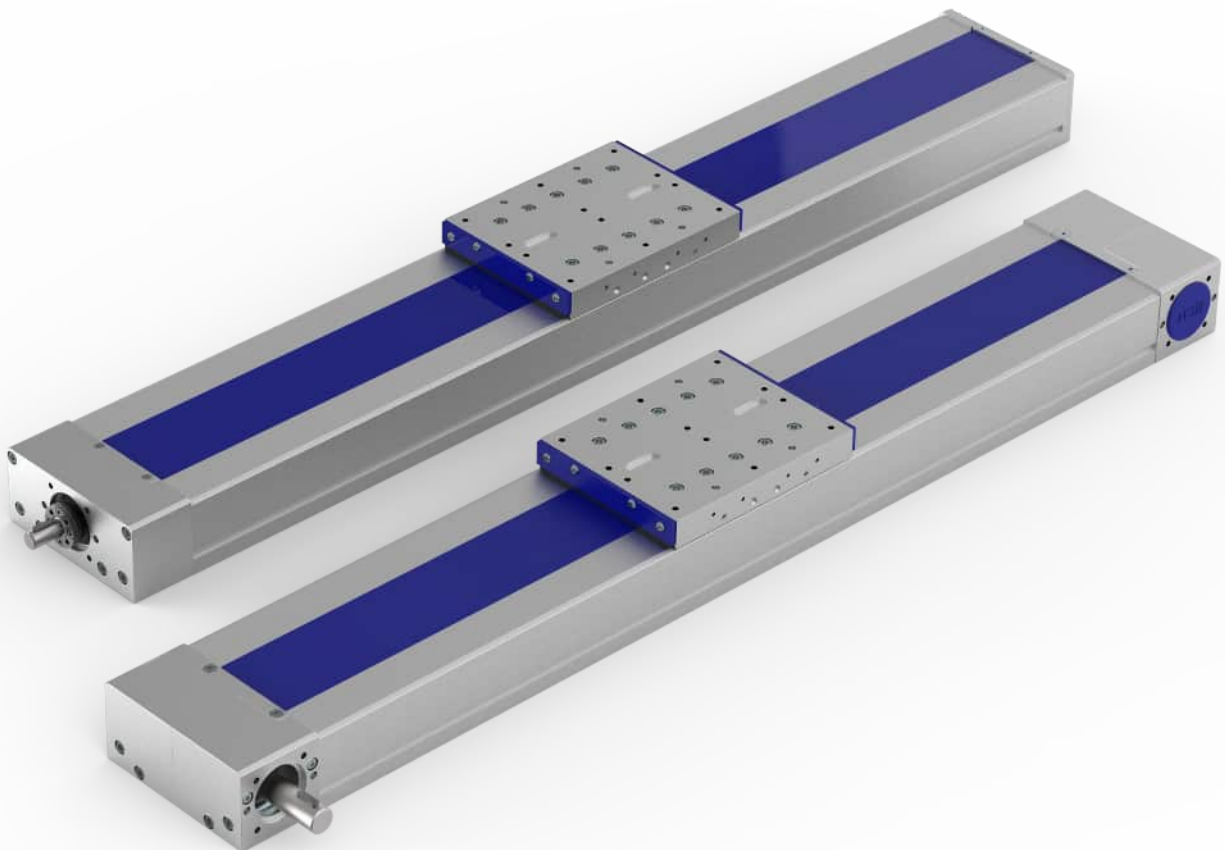

with toothed belt drive and roller guide (ZRS)

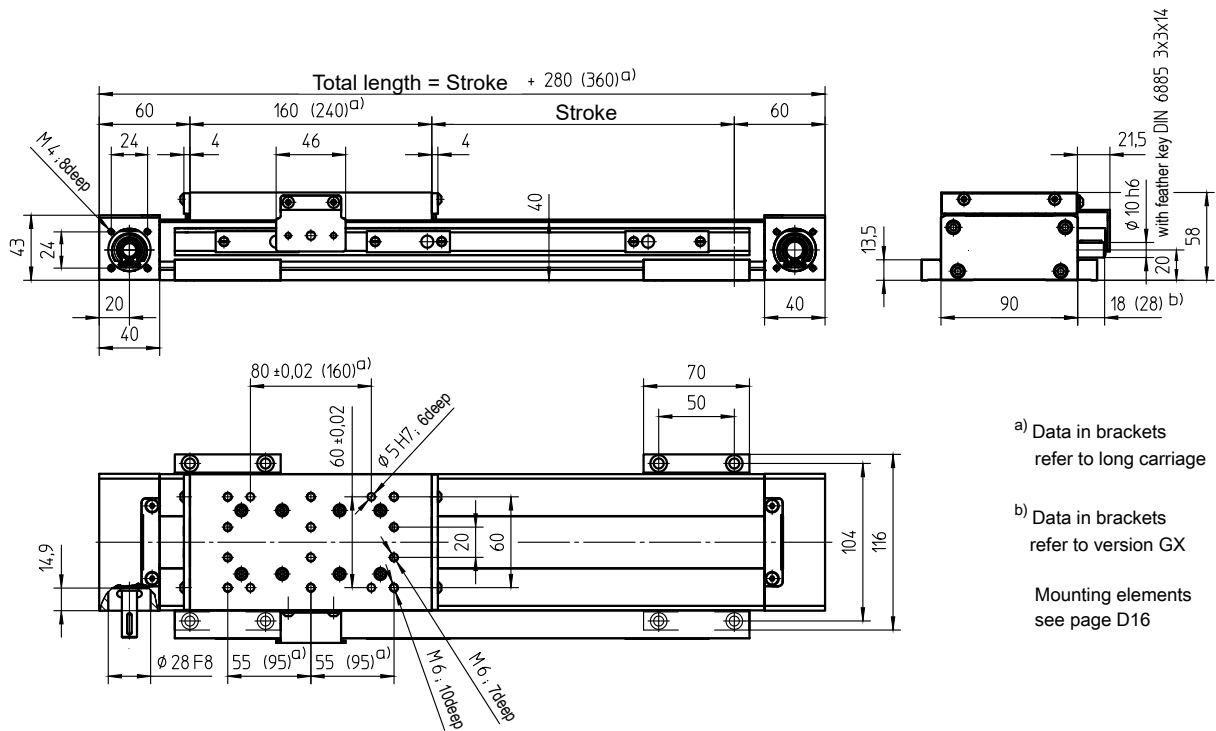

a) Data in brackets refer to long carriage

b) Data in brackets refer to version GX

Mounting elements see page D16

Weights	ZRS
Basic length without stroke:	2.95 kg
100 mm stroke:	0.42 kg
Entire carriage 160 mm:	1.30 kg
Entire carriage 240 mm:	1.85 kg
Max. total length:	4000 mm

Technical Data	ZRS
Max. total speed:	5.00 m/s
Max. acceleration:	30 m/s ²
Repeat accuracy:	± 0.08 mm
Idle torque:	2.00 Nm
Moment of inertia:	4.65 · 10 ⁻⁴ kgm ²
Drive element:	Toothed belt 32 AT5-E
Stroke per revolution:	100 mm

Forces and moments

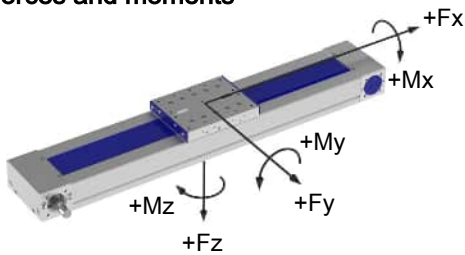

ZRS	
Forces	Dynamic [N]
F _x ^{d)}	800
F _y	500
F _z	1000
-F _z	1000
Moments	Dynamic [Nm]
M _x	60
M _y	80 (110)
M _z	80 (110)

^{d)} Maximum value (see diagram "F_x-v-Diagram")
Data in brackets refer to long carriage (240)

F_x - v - Diagram

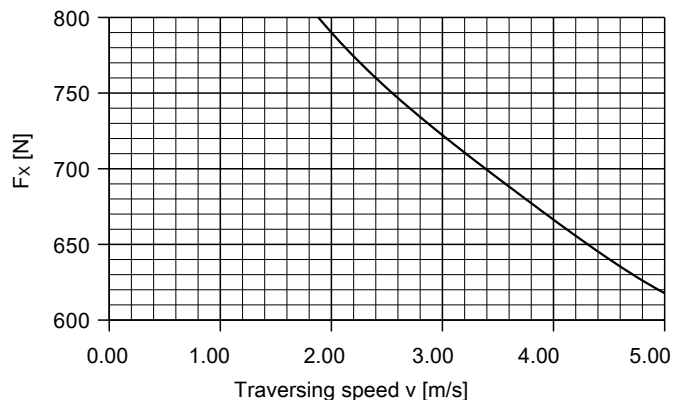

>> **Note** << Drive shaft is not changeable

Please define position, e.g. "AZ1"! (See Ordering Code)

with ball screw (KGT) and roller guide (SRS)

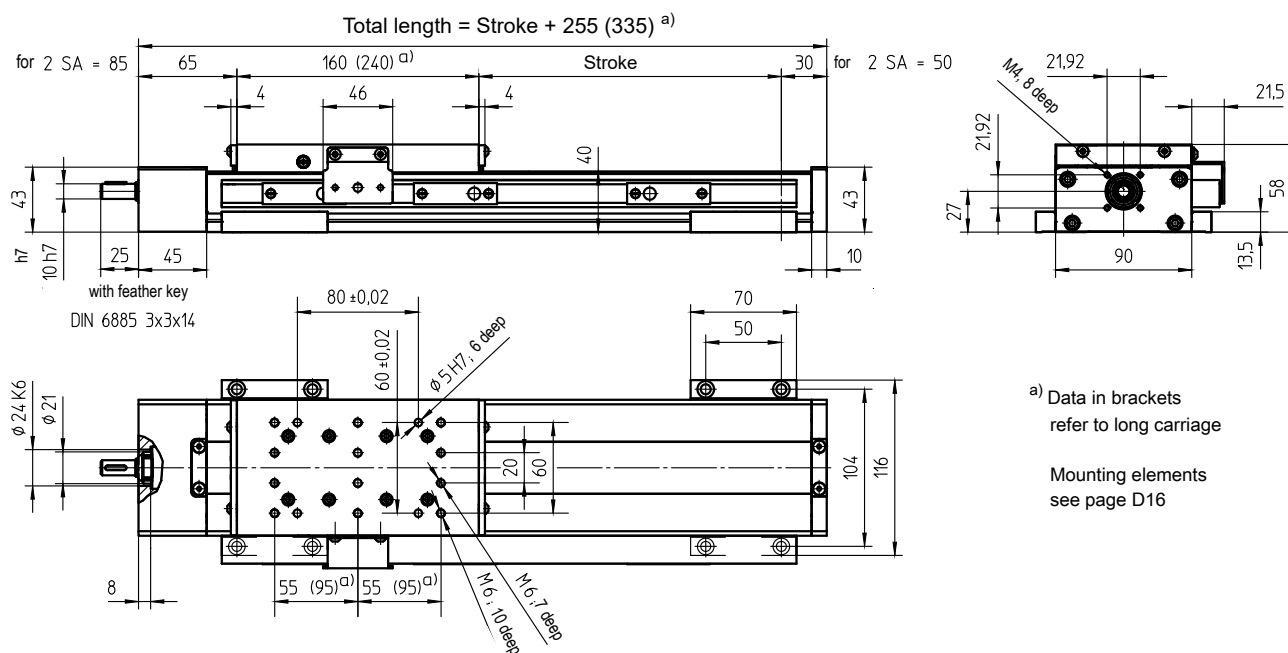

Weights

SRS

Basic length without stroke:	3.25 kg
100 mm stroke:	0.47 kg
Entire carriage 160 mm:	1.30 kg
Entire carriage 240 mm:	1.85 kg
Max. total length:	1500 mm

Technical Data

SRS

Max. total speed:	0.50 m/s
Max. acceleration:	20 m/s ²
Repeat accuracy:	± 0.03 mm (KGT)
Idle torque:	0.30 Nm

Forces and moments

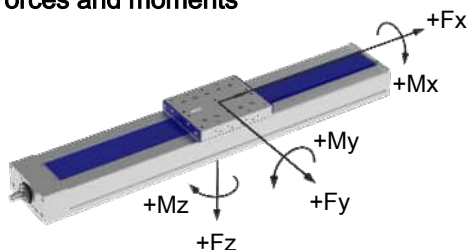

Forces	Dynamic [N]
F _x	1000
F _y	500
F _z	1000
-F _z	1000
Moments	Dynamic [Nm]
M _x	60
M _y	80 (110)
M _z	80 (110)

Data in brackets refer to long carriage (240)

Drive element

KGT

Max. rotation speed:	3000 min ⁻¹
Diameter:	12 mm
Pitch:	5 / 10 mm
Moment of inertia:	1.13 · 10 ⁻⁵ kgm ² /m

Spindle support (SA)

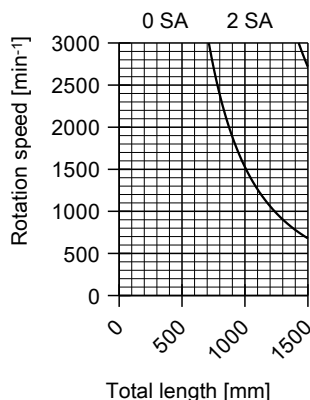

with toothed belt drive and double linear guide (ZSS)

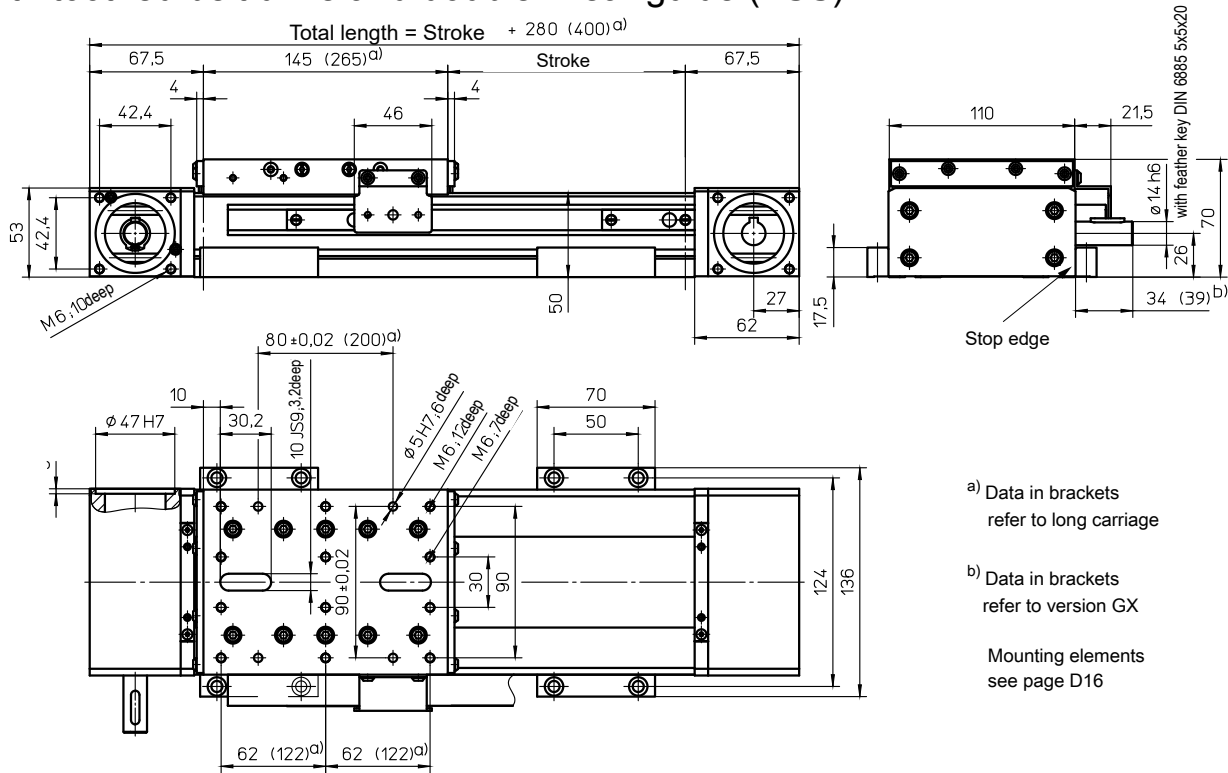

a) Data in brackets refer to long carriage

b) Data in brackets refer to version GX

Mounting elements see page D16

Weights ZSS

Basic length without stroke:	5.10 kg
100 mm stroke:	0.80 kg
Entire carriage 145 mm:	2.20 kg
Entire carriage 265 mm:	3.15 kg
Max. total length:	8100 mm

Technical Data ZSS

Max. total speed:	5.00 m/s
Max. acceleration:	40 m/s ²
Repeat accuracy:	± 0.08 mm
Idle torque:	2.0 Nm
Moment of inertia:	7.60 · 10 ⁻⁴ kgm ²
Drive element:	Toothed belt 50 AT5-E
Stroke per revolution:	110 mm

Forces and moments

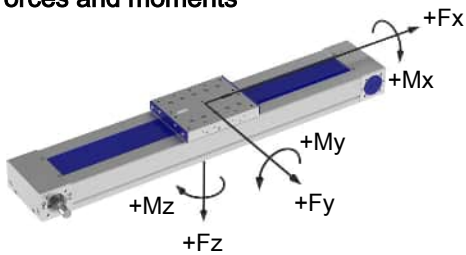

ZSS	
Forces	Dynamic [N]
F_x^{d}	1100
F_y	1200
F_z	3000
$-F_z$	1500
Moments	Dynamic [Nm]
M_x	500
M_y	550 (1000)
M_z	550 (1000)

^{d)} Maximum value (see diagram "Fx - v-Diagram")
Data in brackets refer to long carriage (265)

Fx - v - Diagram

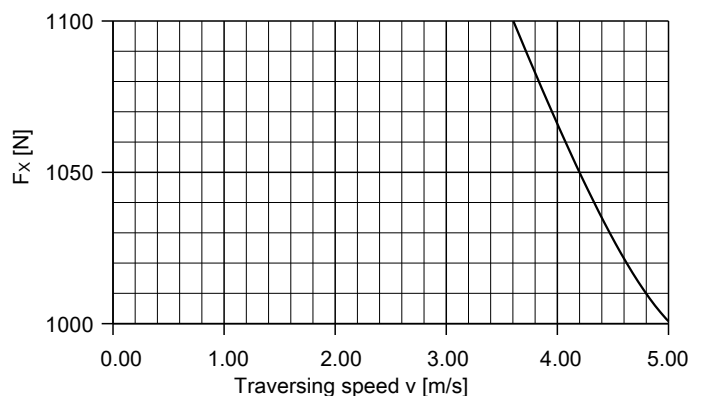

with ball screw (KGT) and double linear guide (SSS)

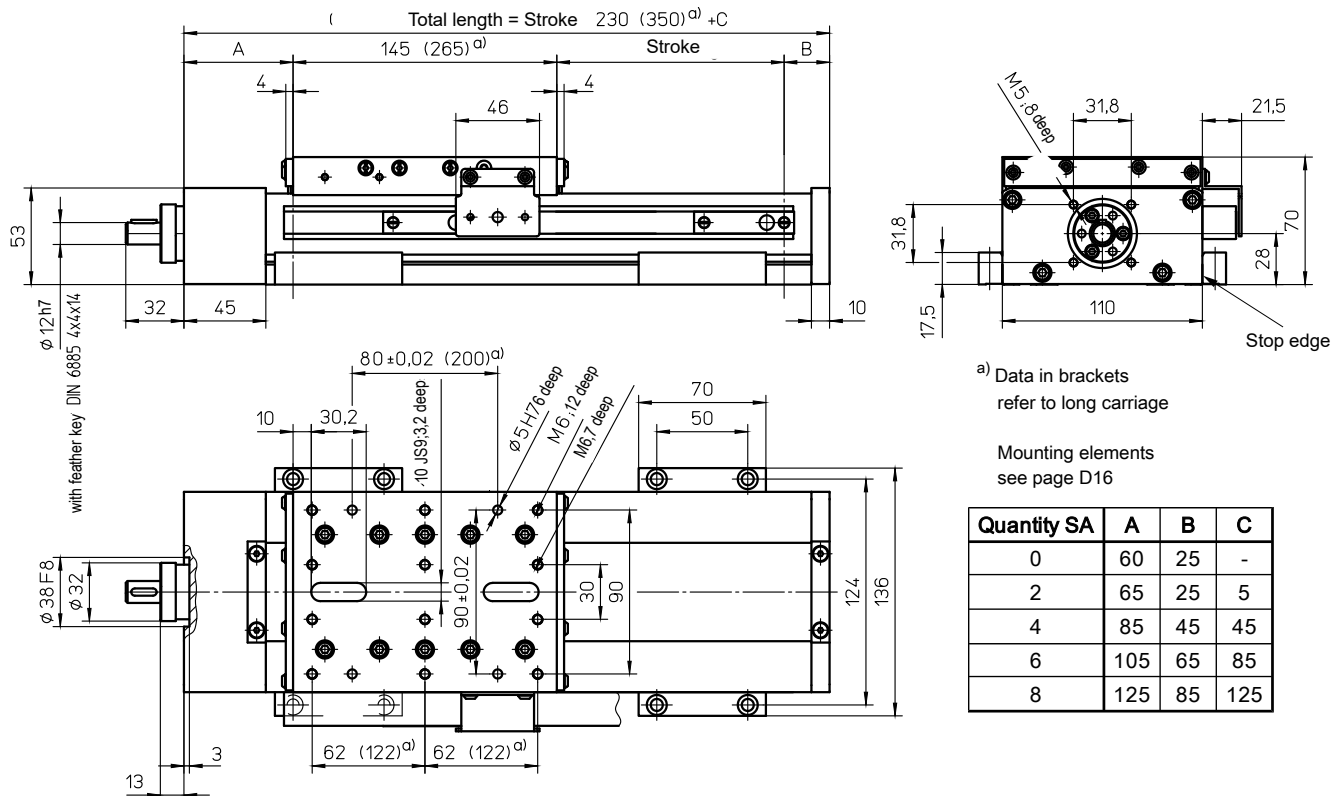

a) Data in brackets refer to long carriage
Mounting elements see page D16

Quantity SA	A	B	C
0	60	25	-
2	65	25	5
4	85	45	45
6	105	65	85
8	125	85	125

Weights

	SSS
Basic length without stroke:	4.90 kg
100 mm stroke:	0.90 kg
Entire carriage 145 mm:	2.30 kg
Entire carriage 265 mm:	3.25 kg
Max. total length:	5600 mm

Technical Data

	SSS
Max. total speed:	2.00 m/s
Max. acceleration:	20 m/s ²
Repeat accuracy:	± 0.03 mm (KGT)
Idle torque:	1.0 Nm

Forces and moments

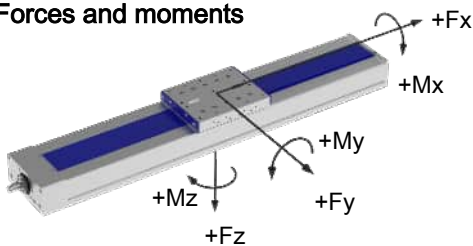

Drive element

	KGT
Max. rotation speed:	3000 min ⁻¹
Diameter:	16 mm
Pitch:	5 / 10 / 20 / 40 mm
Moment of inertia:	3.32 · 10 ⁻⁵ kgm ² /m

	SSS
Forces	Dynamic [N]
F _x	2000
F _y	1200
F _z	3000
-F _z	1500
Moments	Dynamic [Nm]
M _x	500
M _y	550 (1100)
M _z	550 (1100)

Data in brackets refer to long carriage (265)

Spindle support (SA)

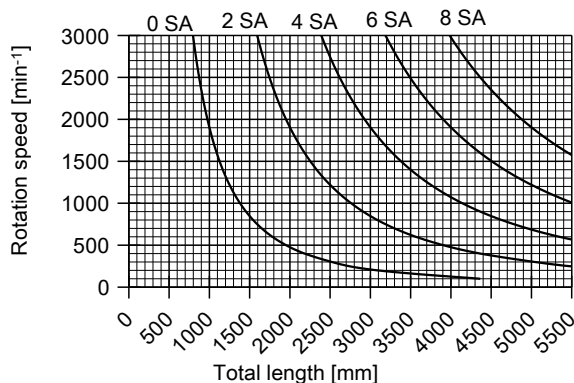

Special design: Spindle support with damping ring (extension of total length: 10 mm for every 2 SA)

with toothed belt drive and double linear guide (ZSS)

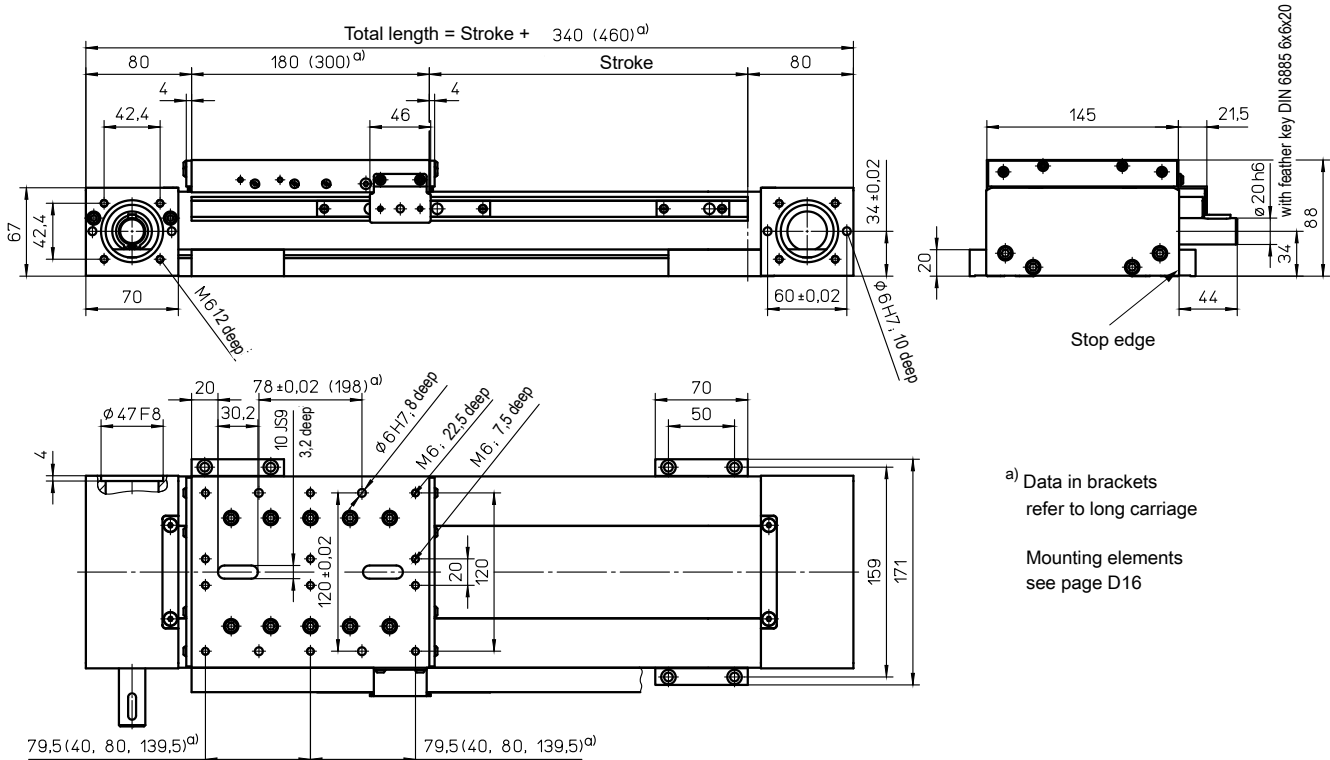

a) Data in brackets refer to long carriage
Mounting elements see page D16

Weights ZSS

Basic length without stroke	10.40 kg
100 mm stroke:	1.30 kg
Entire carriage 180 mm:	3.90 kg
Entire carriage 300 mm:	5.40 kg
Max. total length:	8100 mm

Technical Data ZSS

Max. total speed:	5.00 m/s
Max. acceleration:	40 m/s ²
Repeat accuracy:	± 0.08 mm
Idle torque:	3.00 Nm
Moment of inertia:	2.85 · 10 ⁻³ kgm ²
Drive element:	Toothed belt 60 AT5-E
Stroke per revolution:	150 mm

Forces and moments

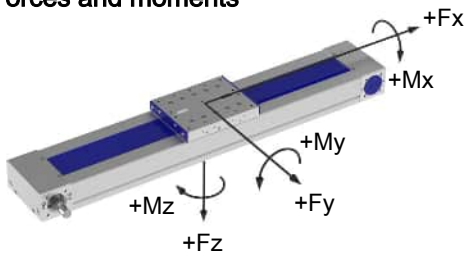

ZSS	
Forces	Dynamic [N]
F _x ^{d)}	2000
F _y	2500
F _z	5000
-F _z	3000
Moments	Dynamic [Nm]
M _x	800
M _y	1000 (1600)
M _z	1000 (1600)

Data in brackets refer to long carriage (300)

Compact module is available in two profile versions:
Stop angle and position of guide support milled = Standard (Delta 145-C-ZSS)
Unmachined = Alternative (Delta 145-C-ZSA)

F_x - v - Diagram

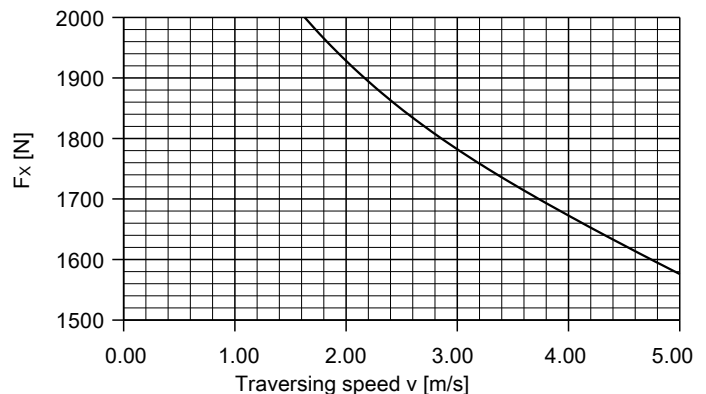

with ball screw (KGT) and double linear guide (SSS)

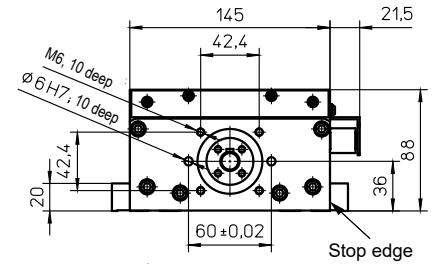
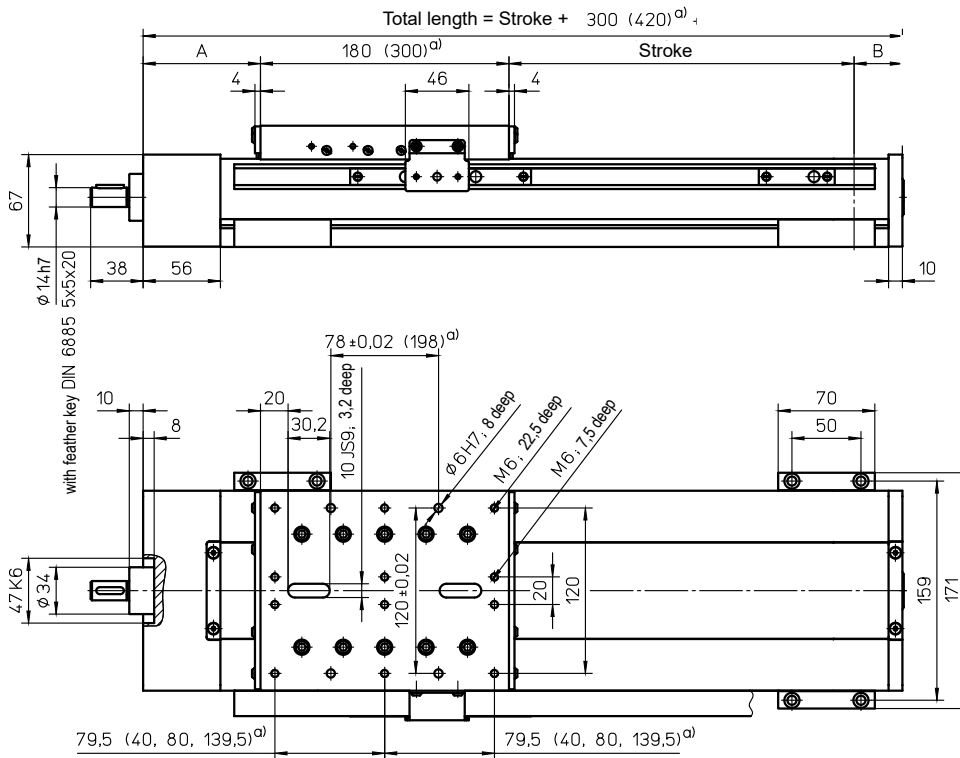

a) Data in brackets refer to long carriage

Shorter carriage
L=120 on request

Mounting elements
see page D16

Quantity SA	A	B	C
0	85	35	-
2	85	35	-
4	115	65	60
6	145	95	120
8	175	125	180

Weights

SSS

Basic length without stroke:	10.30 kg
100 mm stroke:	1.50 kg
Entire carriage 180 mm:	4.90 kg
Entire carriage 300 mm:	6.50 kg
Max. total length:	5600 mm

Technical Data

SSS

Max. total speed:	2.50 m/s
Max. acceleration:	20 m/s ²
Repeat accuracy:	± 0.03 mm (KGT)
Idle torque:	1.00 Nm

Forces and Moments

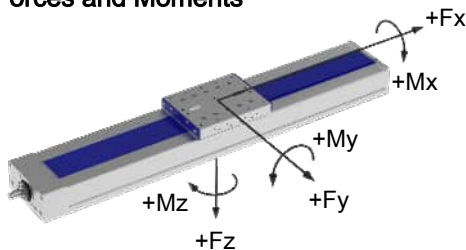

SSS	
Forces	Dynamic [N]
F_x	6000
F_y	2500
F_z	5000
$-F_z$	3000
Moments	Dynamic [Nm]
M_x	800
M_y	1000 (1600)
M_z	1000 (1600)

Data in brackets refer to long carriage (300)

Compact module is available in two profile versions:

Stop angle and position of guide support milled = Standard (Delta 145-C-SSS)

Unmachined = Standard (Delta 145-C-SSA)

Special design: Spindle support with damping ring (extension of total length: 10 mm for every 2 SA)

Drive element

KGT

Max. rotation speed:	3000 min ⁻¹
Diameter:	20 mm
Pitch:	5 / 10 / 20 / 50 mm
Moment of inertia:	8.40 · 10 ⁻⁵ kgm ² /m

Spindle support SA

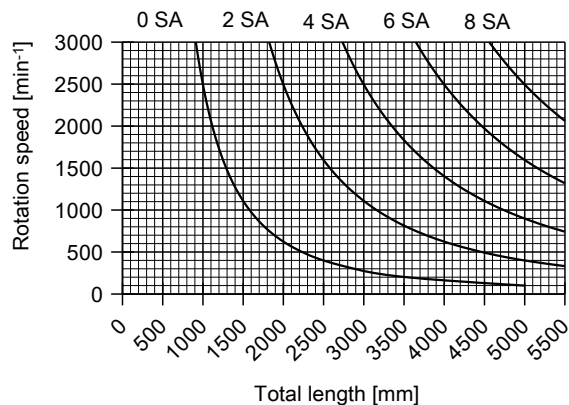

with toothed belt drive and double linear guide (ZSS)

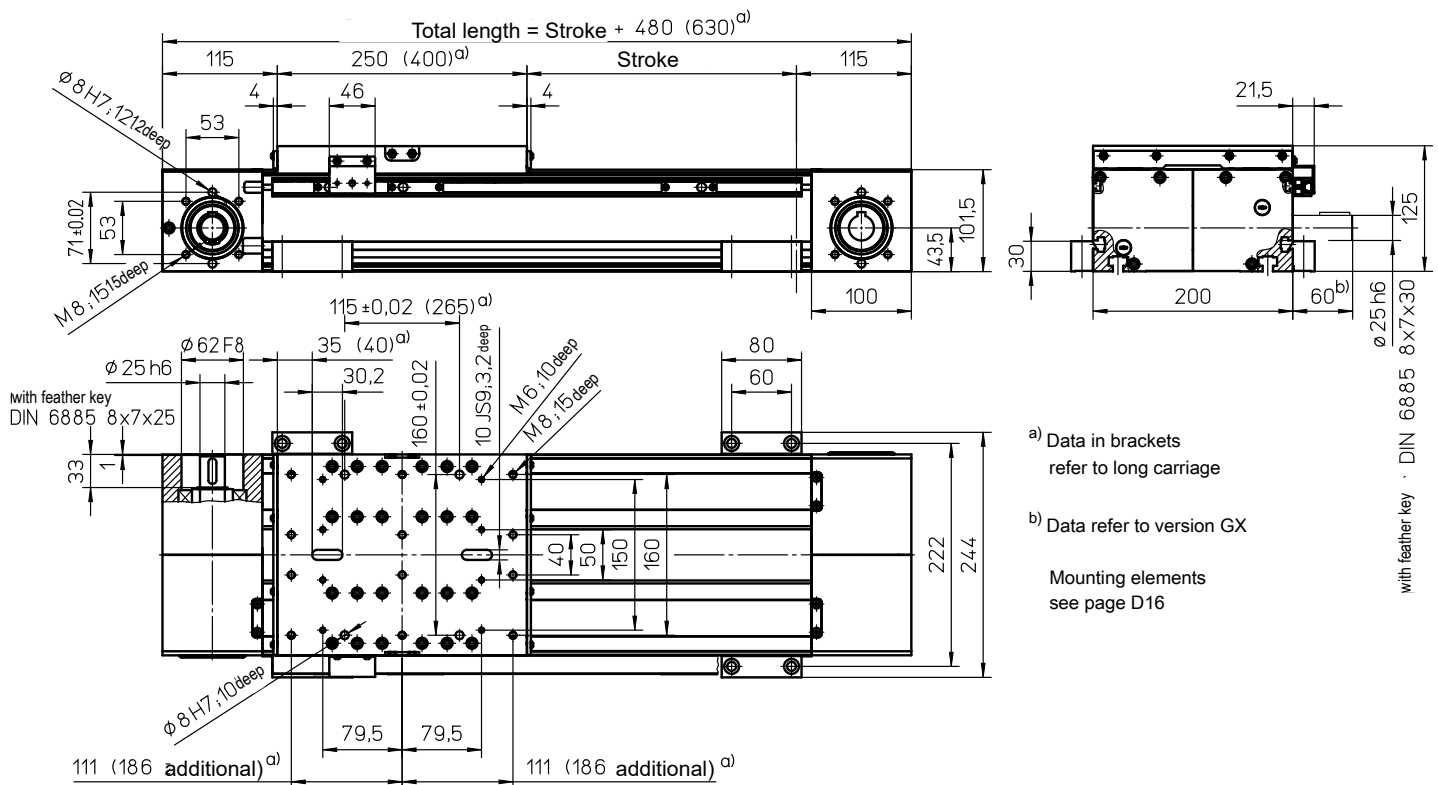

a) Data in brackets refer to long carriage
 b) Data refer to version GX
 Mounting elements see page D16

Weights

ZSS

Basic length without stroke:	25.00 kg
100 mm stroke:	2.00 kg
Entire carriage 250 mm:	8.20 kg
Entire carriage 400 mm:	10.50 kg
Max. total length:	2000 mm

Technical Data

ZSS

Max. total speed:	5.00 m/s
Max. acceleration:	60 m/s ²
Repeat accuracy:	± 0.08 mm
Idle torque:	6.80 Nm
Moment of inertia:	1.20 · 10 ⁻² kgm ²
Drive element:	Toothed belt 75 AT10
Stroke per revolution:	220 mm

Forces and moments

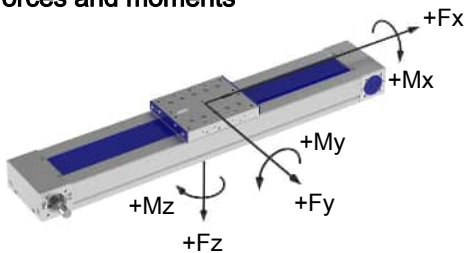

ZSS	
Forces	Dynamic [N]
F_x^{d)}	6000
F_y	5000
F_z	8000
-F_z	5000
Moments	Dynamic [Nm]
M_x	3500
M_y	4300 (6000)
M_z	3200 (4500)

^{d)} Maximum value (see diagram "F_x-v-Diagram")
 Data in brackets refers to long carriage (400)

F_x - v - Diagram

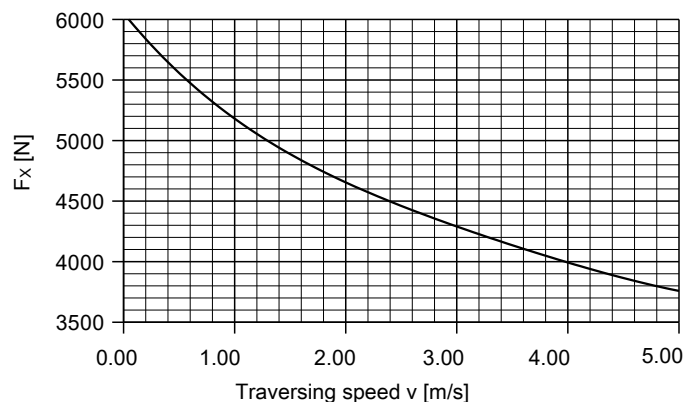

with ball screw (KGT) and double linear guide (SSS)

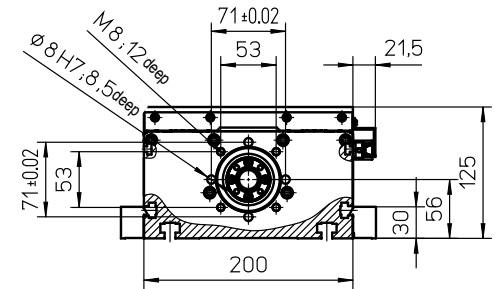
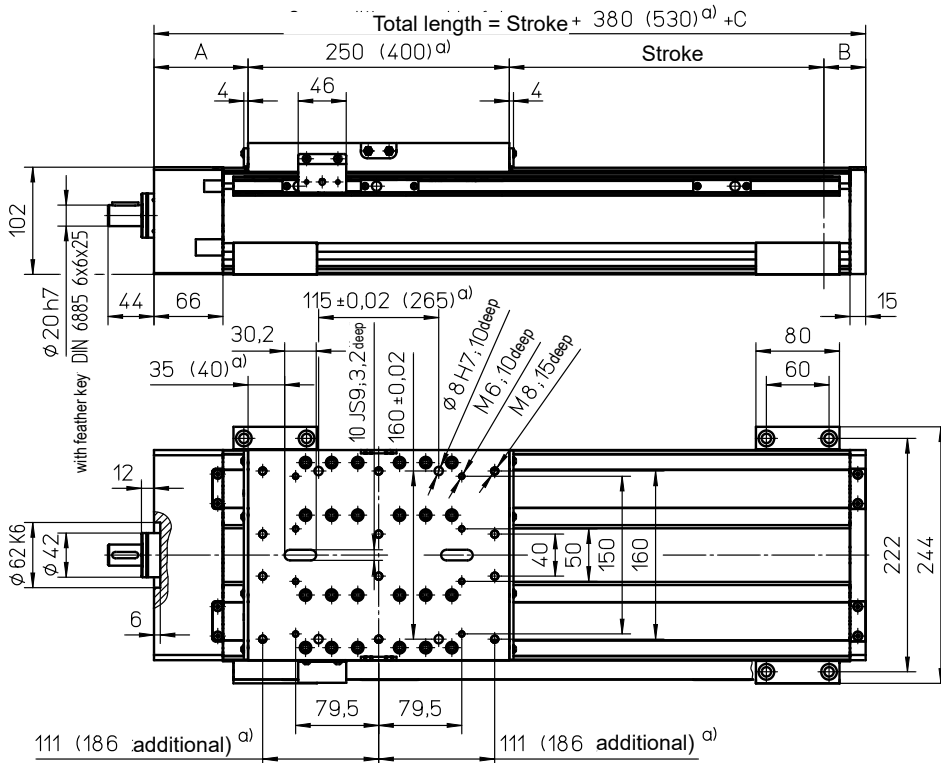

a) Data in brackets refer to long carriage

Mounting elements see page D16

Quantity SA	Version					
	M			MM		
	A	B	C	A	B	C
0	90	40	-	90	40	-
2						

"0 SA" applies for long carriage

Weights

SSS

Basic length without stroke:	22.00 kg
100 mm stroke:	2.60 kg
Entire carriage 250 mm:	8.40 kg
Entire carriage 400 mm:	11.00 kg
Max. total length:	2000 mm

Technical Data

SSS

Max. total speed:	3.00 m/s
Max. acceleration:	20 m/s ²
Repeat accuracy:	± 0.03 mm (KGT)
Idle torque:	2.80 Nm

Forces and moments

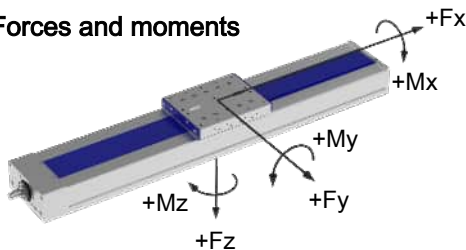

SSS	
Forces	Dynamic [N]
F_x	10000 *
F_y	5000
F_z	8000
$-F_z$	5000
Moments	Dynamic [Nm]
M_x	3500
M_y	4300 (6000)
M_z	3200 (4500)

Data in brackets refer to long carriage (400)

* at KGT 3240 and 3260: 8000 N

Drive element

KGT

Max. rotation speed:	3000 min ⁻¹
Diameter:	32 mm
Pitch:	5 / 10 / 20 / 40 / 60 mm
Moment of inertia:	$6.39 \cdot 10^{-4}$ kgm ² /m

Spindle support (SA)

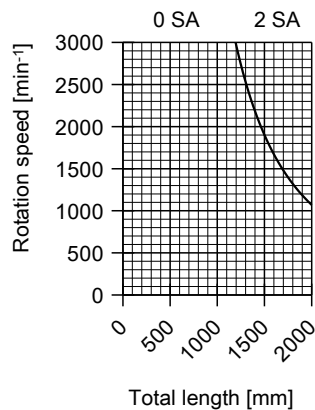

with toothed belt drive and double linear guide (ZSS)

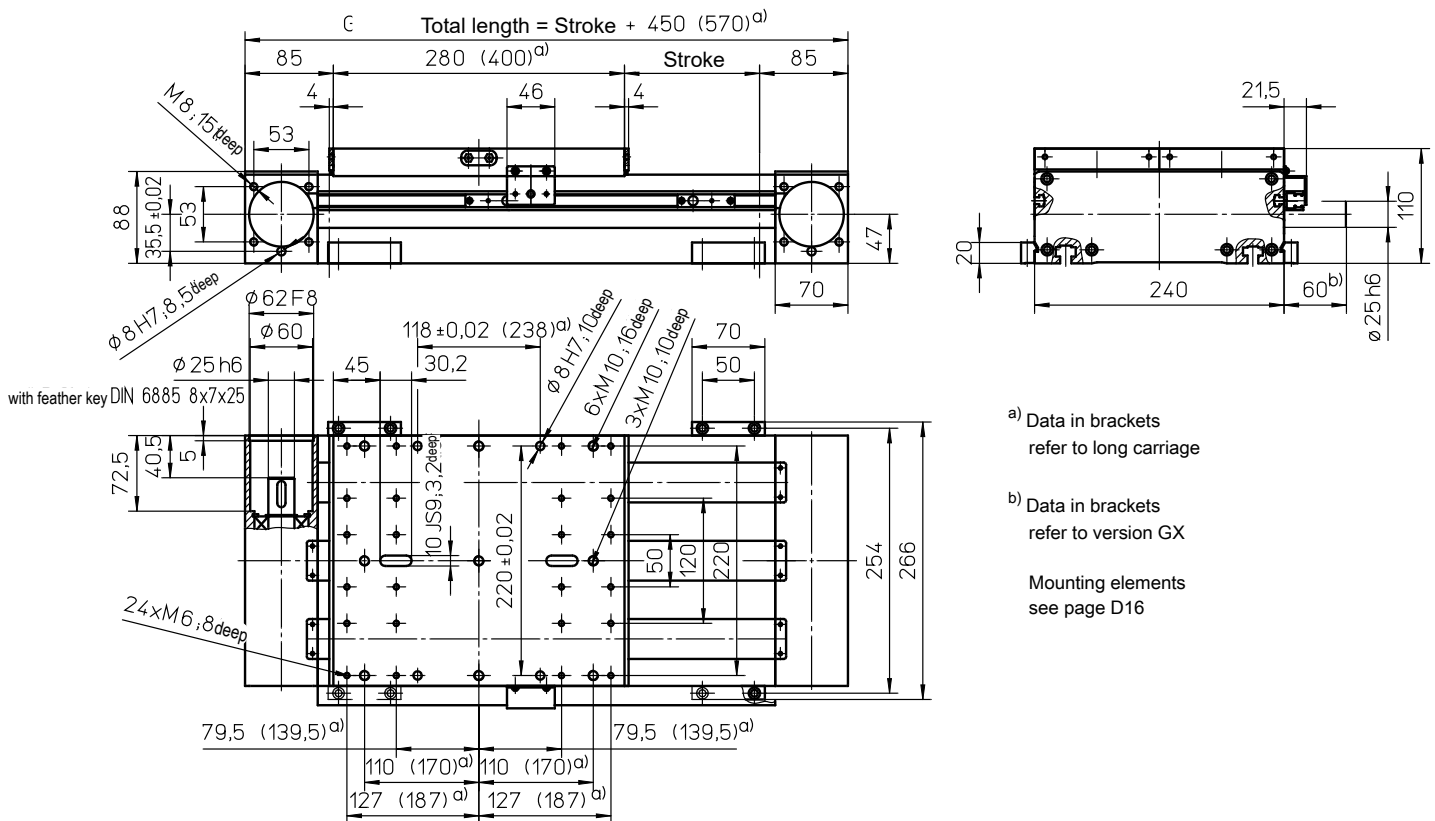

Weights

ZSS

Basic length without stroke:	27.00 kg
100 mm stroke:	3.40 kg
Entire carriage 280 mm:	9.80 kg
Entire carriage 400 mm:	14.00 kg
Max. total length:	3000 mm

Technical Data

ZSS

Max. total speed:	5.00 m/s
Max. acceleration:	60 m/s ²
Repeat accuracy:	± 0.08 mm
Idle torque:	5.50 Nm
Moment of inertia:	2.00 · 10 ⁻² kgm ²
Drive element:	Toothed belt 50 AT10-E
Stroke per revolution:	150 mm

Forces and moments

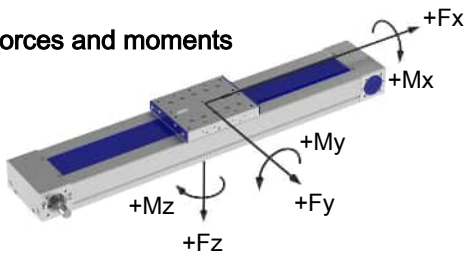

ZSS	
Forces	Dynamic [N]
F _x ^{d)}	2500
F _y	6000
F _z	12000
-F _z	8000
Moments	Dynamic [Nm]
M _x	4500
M _y	6000 (8500)
M _z	4500 (6400)

^{d)} Maximum value (see diagram "F_x - v - Diagram")
Data in brackets refers to long carriage (400)

F_x - v - Diagram

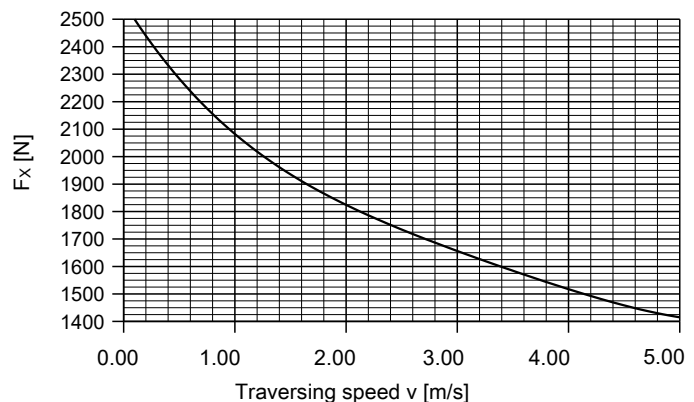

with ball screw (KGT) and double linear guide (SSS)

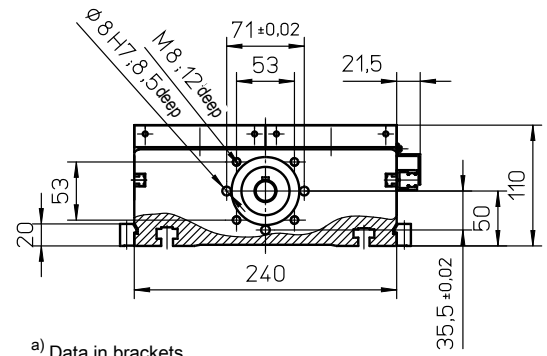
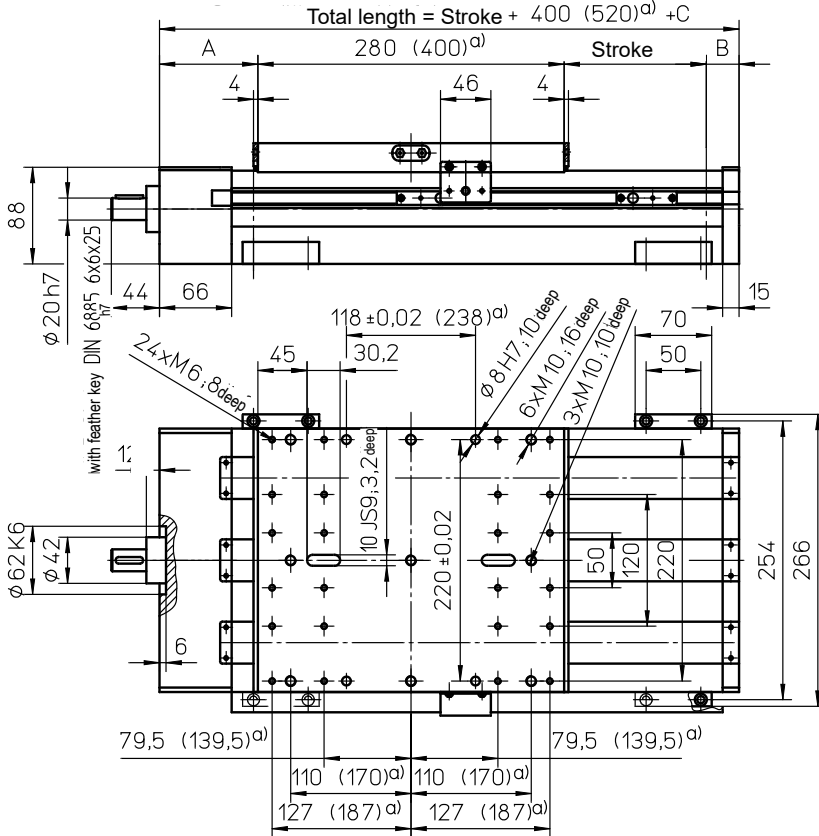

a) Data in brackets refer to long carriage

Mounting elements see page D16

Quantity SA	Version					
	M			MM		
	A	B	C	A	B	C
0	90	30	-	90	30	-
2	130	70	80	130	70	80

"0 SA" applies for long carriage

Weights

	SSS
Basic length without stroke:	26.00 kg
100 mm stroke:	3.90 kg
Entire carriage 280 mm:	10.20 kg
Entire carriage 400 mm:	14.60 kg
Max. total length:	3000 mm

Technical Data

	SSS
Max. total speed:	3.00 m/s
Max. acceleration:	20 m/s ²
Repeat accuracy:	± 0.03 mm (KGT)
Idle torque:	2.80 Nm

Forces and moments

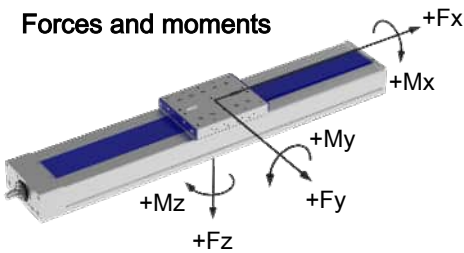

	SSS
Forces	Dynamic [N]
F _x	12000 *
F _y	6000
F _z	12000
-F _z	8000
Moments	Dynamic [Nm]
M _x	4500
M _y	6000 (8500)
M _z	4500 (6400)

Data in brackets refer to long carriage (400)

* at KGT3240 and 3260: 8000 N

Drive element

	KGT
Max. rotation speed:	3000 min ⁻¹
Diameter:	32 mm
Pitch:	5 / 10 / 20 / 40 / 60 mm
Moment of inertia:	6.39 · 10 ⁻⁴ kgm ² /m

Spindle support (SA)

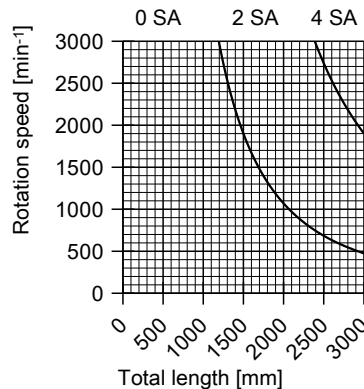

with toothed belt drive and double linear guide (ZSS)

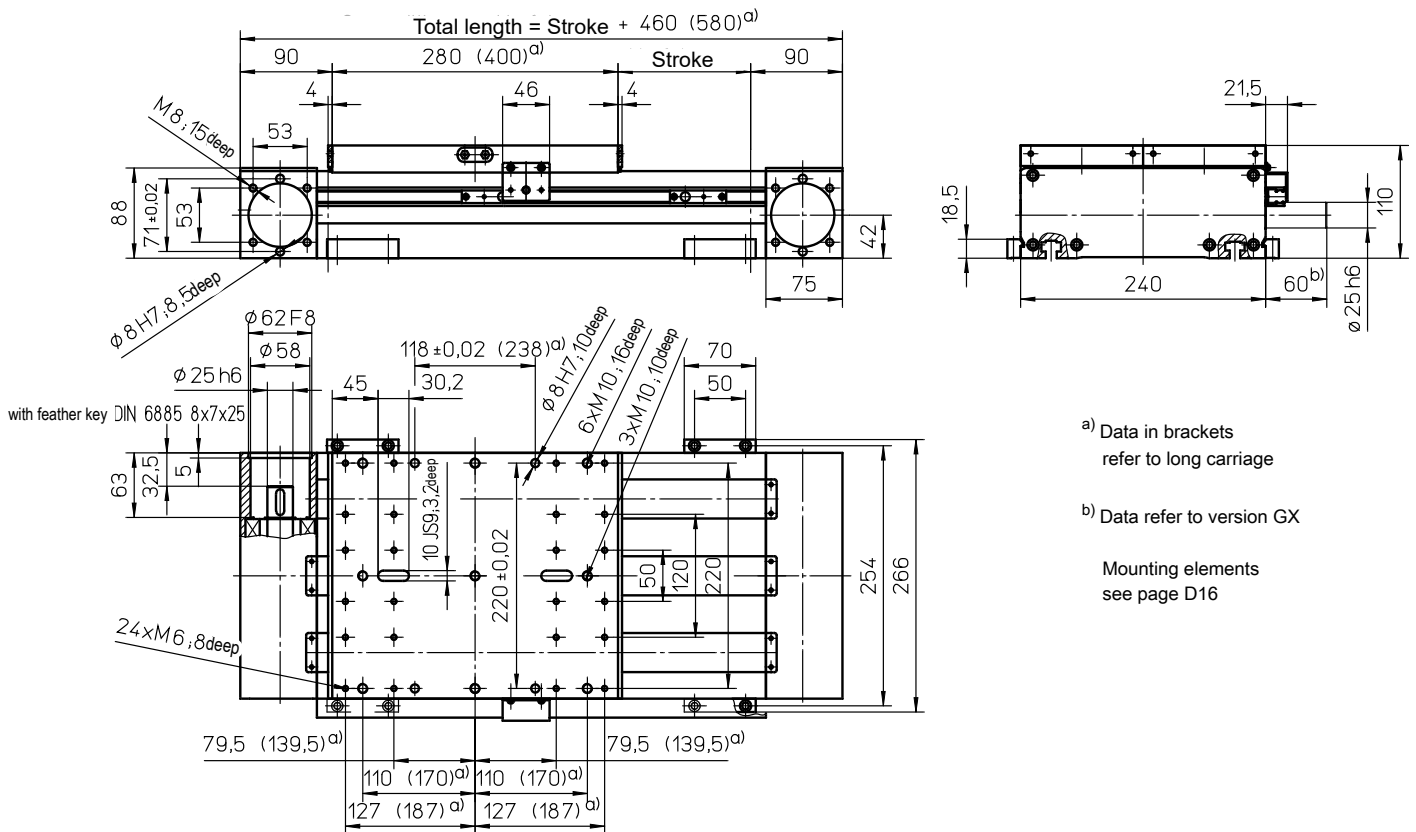

a) Data in brackets refer to long carriage
 b) Data refer to version GX
 Mounting elements see page D16

Weights ZSS

Basic length without stroke:	25.50 kg
100 mm stroke:	2.75 kg
Entire carriage 280 mm:	9.80 kg
Entire carriage 400 mm:	14.00 kg
Max. total length:	8000 mm

Technical Data ZSS

Max. total speed:	5.00 m/s
Max. acceleration:	60 m/s ²
Repeat accuracy:	± 0.08 mm
Idle torque:	5.50 Nm
Moment of inertia:	2.60 · 10 ⁻² kgm ²
Drive element:	Toothed belt 60 ATL10
Stroke per revolution:	180 mm

Forces and moments

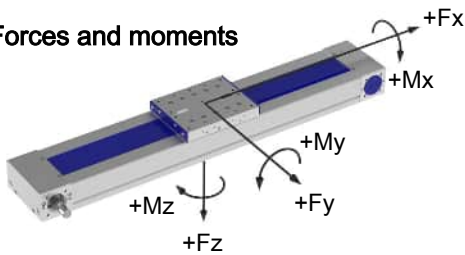

ZSS	
Forces	Dynamic [N]
F _x ^{d)}	3800
F _y	6000
F _z	12000
-F _z	8000
Moments	Dynamic [Nm]
M _x	4500
M _y	6000 (8500)
M _z	4500 (6400)

^{d)} Maximum value (see diagram "F_x-v-Diagram")
 Data in brackets refer to long carriage (400)

F_x - v - Diagram

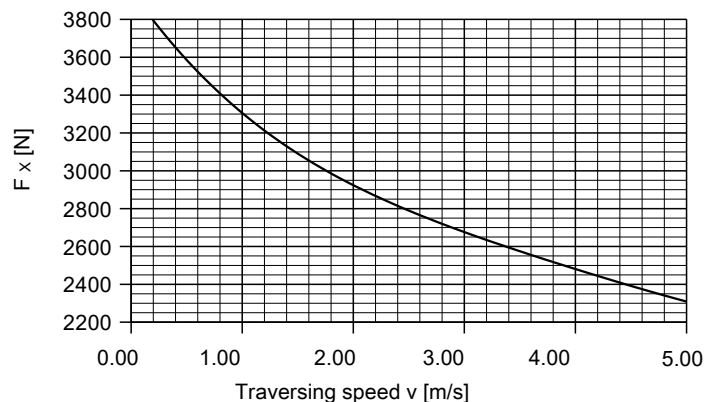

with ball screw (KGT) and double linear guide (SSS)

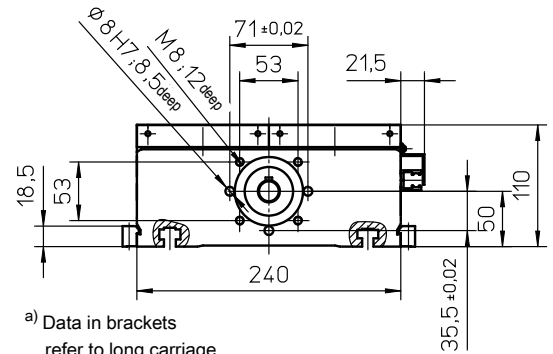
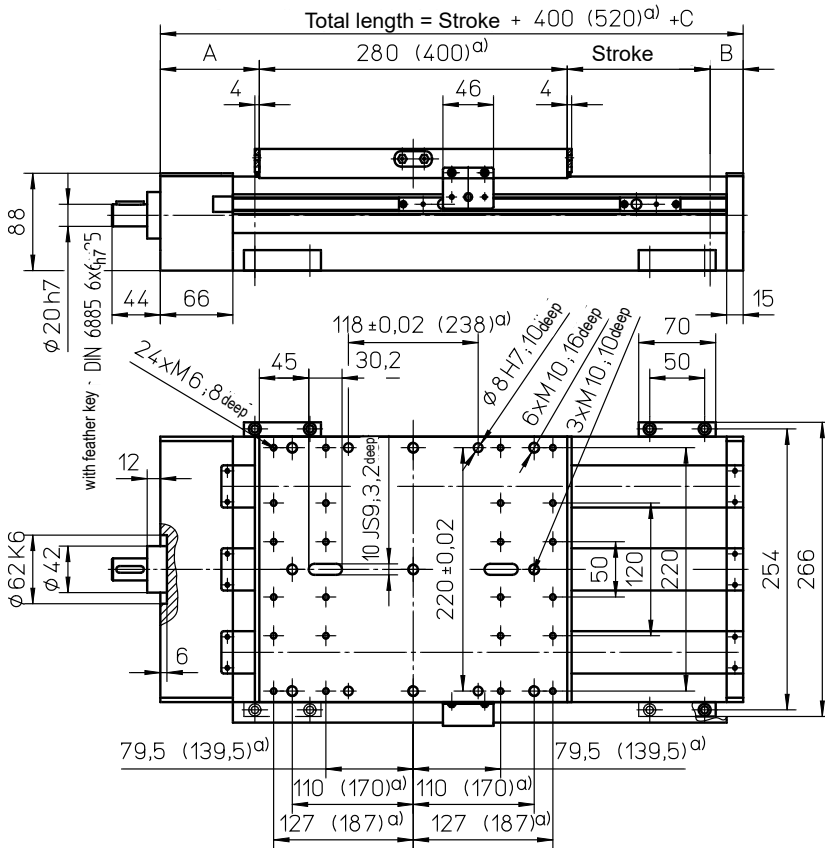

a) Data in brackets refer to long carriage

Mounting elements see page D16

Quantity SA	Version					
	M			MM		
	A	B	C	A	B	C
0	90	30	-	90	30	-
2	130	70	80	130	70	80

"0 SA" applies for long carriage

Weights

SSS

Basic length without stroke:	24.20 kg
100 mm stroke:	3.25 kg
Entire carriage 280 mm:	10.20 kg
Entire carriage 400 mm:	14.60 kg

Max. total length: 5600 mm

Forces and moments

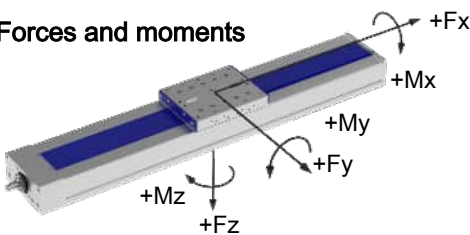

SSS	
Forces	Dynamic [N]
F_x	12000 *
F_y	6000
F_z	12000
$-F_z$	8000
Moments	Dynamic [Nm]
M_x	4500
M_y	6000 (8500)
M_z	4500 (6400)

Data in brackets refer to long carriage (400)

* at KGT3240 and 3260: 8000 N

Technical Data

SSS

Max. total speed:	3.00 m/s
Max. acceleration:	20 m/s ²
Repeat accuracy:	± 0.03 mm (KGT)
Idle torque:	2.80 Nm

Drive element

KGT

Max. rotation speed:	3000 min ⁻¹
Diameter:	32 mm
Pitch:	5 / 10 / 20 / 40 / 60 mm
Moment of inertia:	6.39 · 10 ⁻⁴ kgm ² /m

Spindle support (SA)

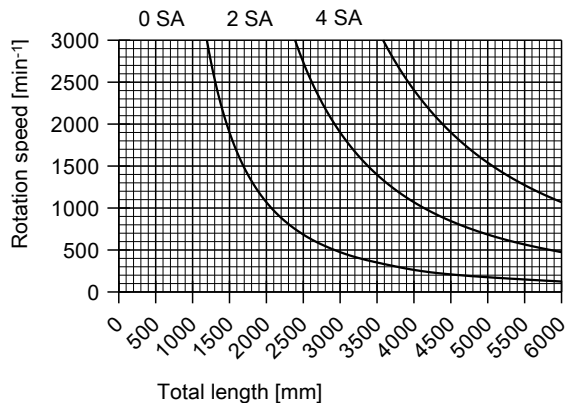

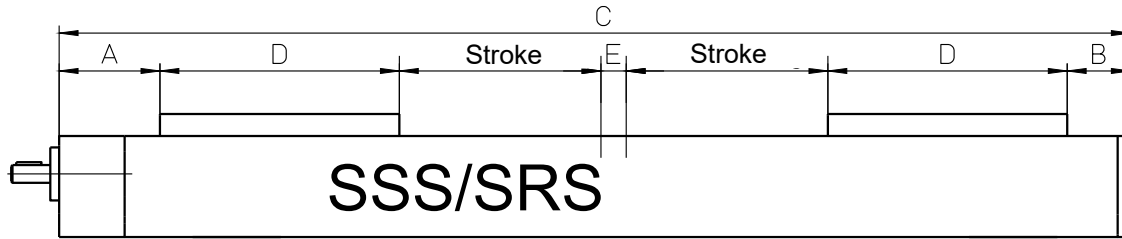

Unit size	A [mm]	B [mm]	Total length C [mm]	D [mm]	E [mm]	Screw drive ^{b)}
Delta 90-SRS	65	30	2 x stroke + 415 (575) ^{a)} + E 80 mm extension for every 4 SA	160 (240) ^{a)}	min. 50 without SA	KGT 1205 or Tr 12x3
Delta 110-C-SSS	60	25	2 x stroke + 375 (615) ^{a)} + E 45 mm extension for every 4 SA	145 (265) ^{a)}	min. 20 without SA	KGT 1605 or Tr 16x4
Delta 145-C-SSS	85	35	2 x stroke + 480 (720) ^{a)} + E 60 mm extension for every 4 SA	180 (300) ^{a)}	min. 30 without SA	KGT 2005 or Tr 20x4
Delta 200-SSS	90	40	2 x stroke + 630 (930) ^{a)} + E 120 mm extension for every 4 SA	250 (400) ^{a)}	min. 30 without SA	KGT 3205 or Tr 32x6
Delta 240(-C)-SSS	90	30	2 x stroke + 680 (920) ^{a)} + E 80 mm extension for every 4 SA	280 (400) ^{a)}	min. 30 without SA	KGT 3205 or Tr 32x6

For detailed measurements, see main dimensions sheet for respective size

^{a)} Data in brackets apply to long carriage

^{b)} Load ratings for KGT see table on page TL13

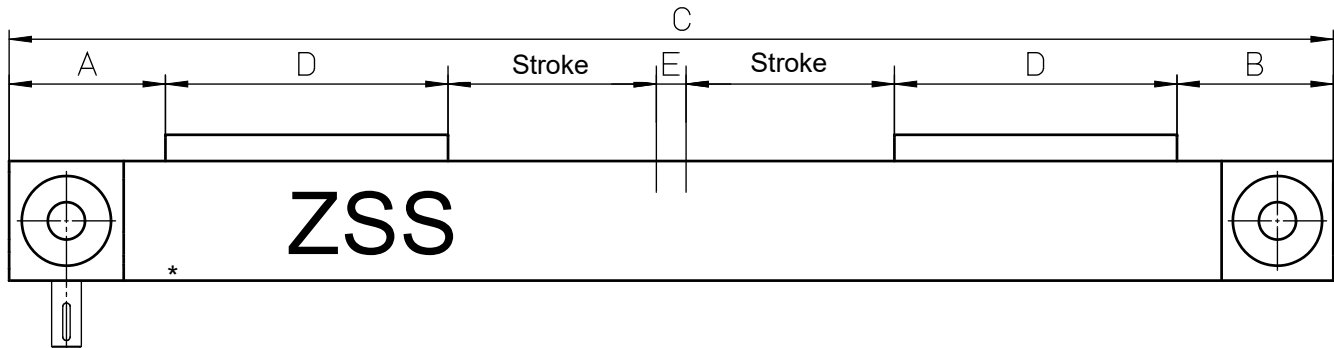

Unit size	A [mm]	B [mm]	Total length C [mm]	D [mm]	E [mm]
Delta 110-C*	67,5	67,5	2 x stroke + 445 (685) ^{a)} + E	145 (265) ^{a)}	min. 20
Delta 145-C	80	80	2 x stroke + 545 (785) ^{a)} + E	180 (300) ^{a)}	min. 25
Delta 200	115	115	2 x stroke + 746 (1046) ^{a)} + E	250 (400) ^{a)}	min. 16

For detailed measurements, see main dimensions sheet for respective size (version).

* Drive shaft downwards

^{a)} Data in brackets apply to long carriage

Please note that the technical data of the axes may change for right/left versions.

Individual technical advice from our sales department is therefore required depending on the application.

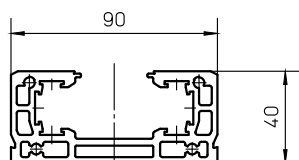

Profile Delta 90

Specific mass [kg/m]	3.26
Surface measure [mm ²]	1207
Geometrical moment of inertia I _y [mm ⁴]	223339
Geometrical moment of inertia I _z [mm ⁴]	1195788
Section modulus W _y [mm ³]	9982
Section modulus W _z [mm ³]	26573

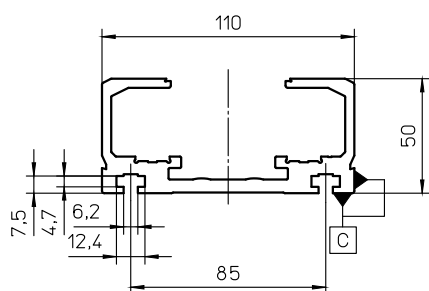

Profil Delta 110-C

Specific mass [kg/m]	4.32
Surface measure [mm ²]	1601
Geometrical moment of inertia I _y [mm ⁴]	446420
Geometrical moment of inertia I _z [mm ⁴]	2505144
Section modulus W _y [mm ³]	13426
Section modulus W _z [mm ³]	44851

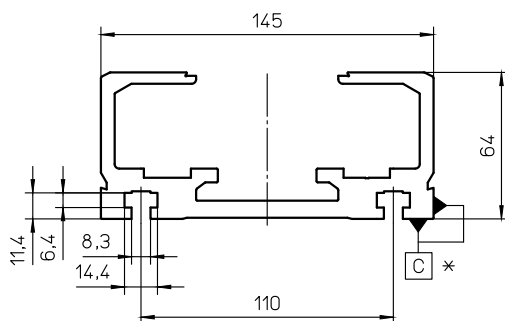

Profile Delta 145-C

Specific mass [kg/m]	7.8
Surface measure [mm ²]	2899
Geometrical moment of inertia I _y [mm ⁴]	1251254
Geometrical moment of inertia I _z [mm ⁴]	7737207
Section modulus W _y [mm ³]	29621
Section modulus W _z [mm ³]	105418

* Valid for version with machined profile.

C: Stop edge standard page C

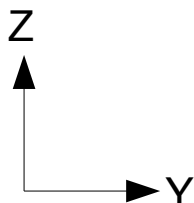

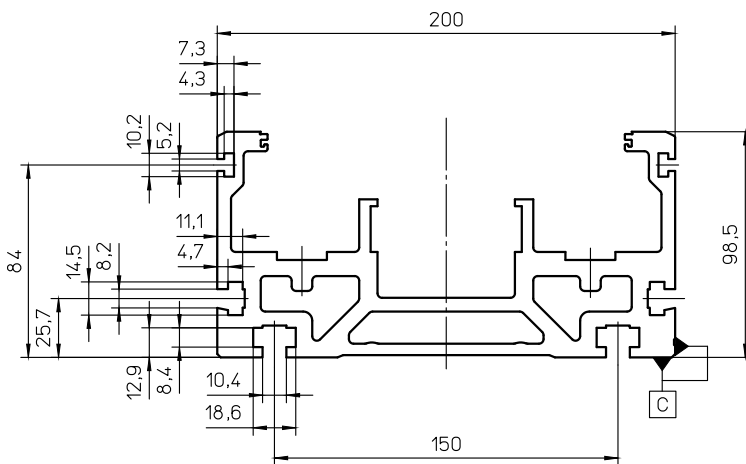

Profile Delta 200

Specific mass [kg/m]	15.7
Surface measure [mm ²]	5805
Geometrical moment of inertia I _y [mm ⁴]	3889990
Geometrical moment of inertia I _z [mm ⁴]	28139811
Section modulus W _y [mm ³]	59044
Section modulus W _z [mm ³]	278731

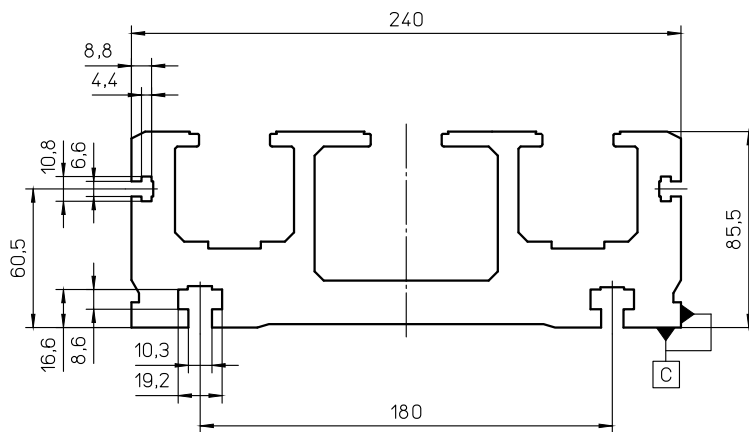

Profile Delta 240

Specific mass [kg/m]	26.6
Surface measure [mm ²]	9850
Geometrical moment of inertia I _y [mm ⁴]	6369119
Geometrical moment of inertia I _z [mm ⁴]	59788355
Section modulus W _y [mm ³]	120820
Section modulus W _z [mm ³]	498219

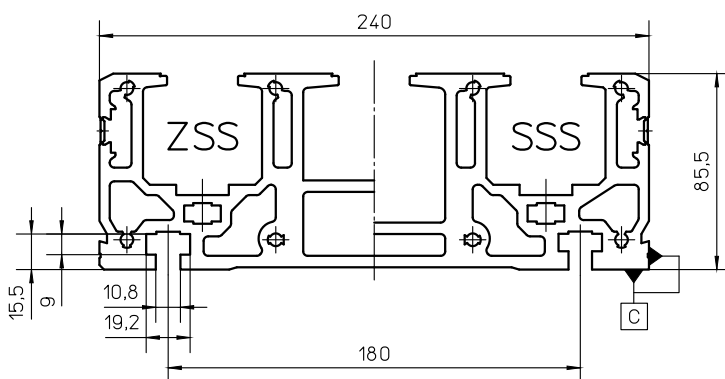

Profil Delta 240-C

ZSS

Specific mass [kg/m]	18.5
Surface measure [mm ²]	6848
Geometrical moment of inertia I _y [mm ⁴]	4850972
Geometrical moment of inertia I _z [mm ⁴]	38448286
Section modulus W _y [mm ³]	97446
Section modulus W _z [mm ³]	320402

SSS

Specific mass [kg/m]	18.5
Surface measure [mm ²]	6850
Geometrical moment of inertia I _y [mm ⁴]	4944409
Geometrical moment of inertia I _z [mm ⁴]	38449888
Section modulus W _y [mm ³]	97673
Section modulus W _z [mm ³]	320416

C : Stop edge standard page C

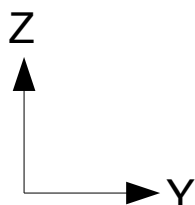

NS 1 / 2 / 4 / 6 / 22 / 23

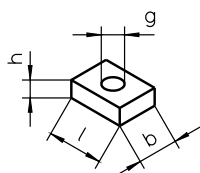

NS 4.1 / 10

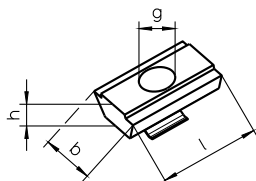

RM 2 / 4 / 6

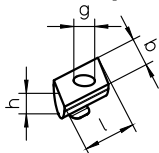

NS 24

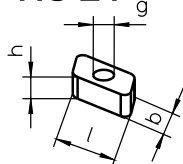

Linear drive	Page *	NS	ID No.	l [mm]	b [mm]	h [mm]	g
Delta 110-C	E	22	27352	18	12	4.5	M5
		23	28914	18	12	4.5	M6
		RM2	15370	10	6	4	M4
Delta 145-C	E	4	10559	18	14	6	M8
		4.1	16552	20	13	6	M8
		10	16499	20	13	6	M6
		RM4	15371	13	8	6	M5
Delta 200	E	6	10561	25	18	8	M10
		RM6	15372	18	10	8	M6
	C and D below	4	10559	18	14	6	M8
		4.1	16552	20	13	6	M8
		10	16499	20	13	6	M6
		RM4	15371	13	8	6	M5
C and D below	1	10556	12	10	4	M4	
	2	10557	16	10	4	M5	
Delta 240	E	6	10561	25	18	8	M10
		24	16772	25	17	9.5	M10
		RM6	15372	18	10	8	M6
	C and D	1	10556	12	10	4	M4
		2	10557	16	10	4	M5
		RM2	15370	10	6	4	M4
Delta 240-C	E	6	10561	25	18	8	M10
		24	16772	25	17	9.5	M10
		RM6	15372	18	10	8	M6

BL 1..4 / 8 / 10

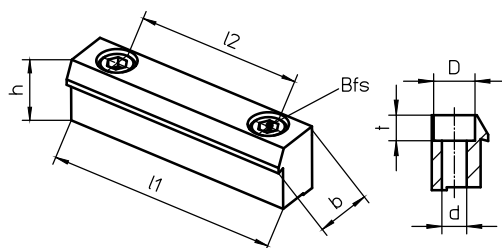

Linear drive	BL	ID No.	l1 [mm]	l2 [mm]	b [mm]	h [mm]	Bfs	D [mm]	d [mm]	t [mm]
Delta 90	8	18447	70	50	15	13,5	M6	11	6,6	6,8
Delta 110-C	1.1	13224	49	30	15	17,5	M6	11	6,6	6,8
	1	10552	70	50	15	17,5	M6	11	6,6	6,8
Delta 145-C	2	10553	70	50	15	20	M6	11	6,6	6,8
Delta 200	3	10554	80	60	25	30	M8	15	9	9
Delta 240	4	10555	70	50	16	20	M6	11	6,6	6,8
Delta 240-C	10	17326	70	50	15	18,5	M6	11	6,6	6,8

* For further information on pages C..E, see catalogue page Z1
 Bfs = Mounting screw DIN 912 / ISO 4762

Example:

Delta 145-C-ZSS-50 AT5-E-110-1000-1340-AK-AZ1-8RM4-1

Product

Unit size (version*)

Drive

Z = Toothed belt drive

0 = Without drive

Guide system

S = Rail guide

R = Roller guide

Model

S = Standard ; A = Alternative (profile unmachined)

Drive specifications

Width and type of toothed belt

Stroke per revolution

Stroke

Total length

Cover

AK = Cover band

Accessories

AZ1 = Drive shaft short, mounting side **C**

AZ2 = Drive shaft short, mounting side **D**

AZ6 = Drive shaft long, mounting side **C** and **D**

AZX = Integrated drive shaft (standard, not Delta 110-C and 145-C)

Further arrangements for drive shaft, see **page Z1**

EO2 / EO10 = Inductive limit switch NC with 2 m / 10 m cable fitted

ES2 / ES10 = Inductive limit switch NO with 2 m / 10 m cable fitted

EMS / EMB = Mechanical limit switch (S = Siemens, B = Balluff) fitted

BL = Mounting bracket

NS / RM = Sliding block 1 .. 21 / Rhomb nut 2 .. 6 (see Table on **page D16**)

Special design

0 = Standard

1 = Special (add specification description)

Further accessories (separate position)

MGK = Motor mounting and coupling (according to dimension sheet)

URT = Deflection belt drive (according to dimension sheet)

* e.g. Delta 240-ZSS or Delta 240-C-ZSS

Example: Delta 145-C-SSS-M-2010-1000-1360-2SA-2ES2-6BL2-0

Product

Unit size (version*)

Drive

S = Spindle

0 = Without drive

Guide system

S = Rail guide

R = Roller guide

Model

S = Standard ; A = Alternative (profile unmachined)

Type of drive

M = Single nut (ball screw)

MM = Double nut (ball screw)

(TR = Trapezoidal screw - optional)

Drive specifications

Diameter and pitch (ball screw)

(Diameter x pitch (trapezoidal screw) - optional)

Stroke

Total length

Spindle support (SA)

(quantity)

Accessories

EO2 / EO10 = Inductive limit switch NC with 2m / 10m cable fitted

ES2 / ES10 = Inductive limit switch NO with 2m / 10m cable fitted

EMS / EMB = Mechanical limit switch (S = Siemens, B = Balluff) fitted

BL = Mounting bracket

NS / RM = Sliding block 1 .. 21 / Rhomb nut 2 .. 6 (see Table on **page D16**)

Special design

0 = Standard

1 = Special (add specification description)

Further accessories (separate position)

MGK = Motor mounting and coupling (according to dimension sheet)

URT = Deflection belt drive (according to dimension sheet)

For mounting of limit switches and lubrication points, see **page Z1**

Cover band comes as standard for screw drive

Further drives available on request:

MK or TK (= single nut made of plastic), KK (= double nut made of plastic)

* e.g. Delta 240-SSS or Delta 240-C-SSS

Chapter A

Linear Table

HSB-alpha[®]

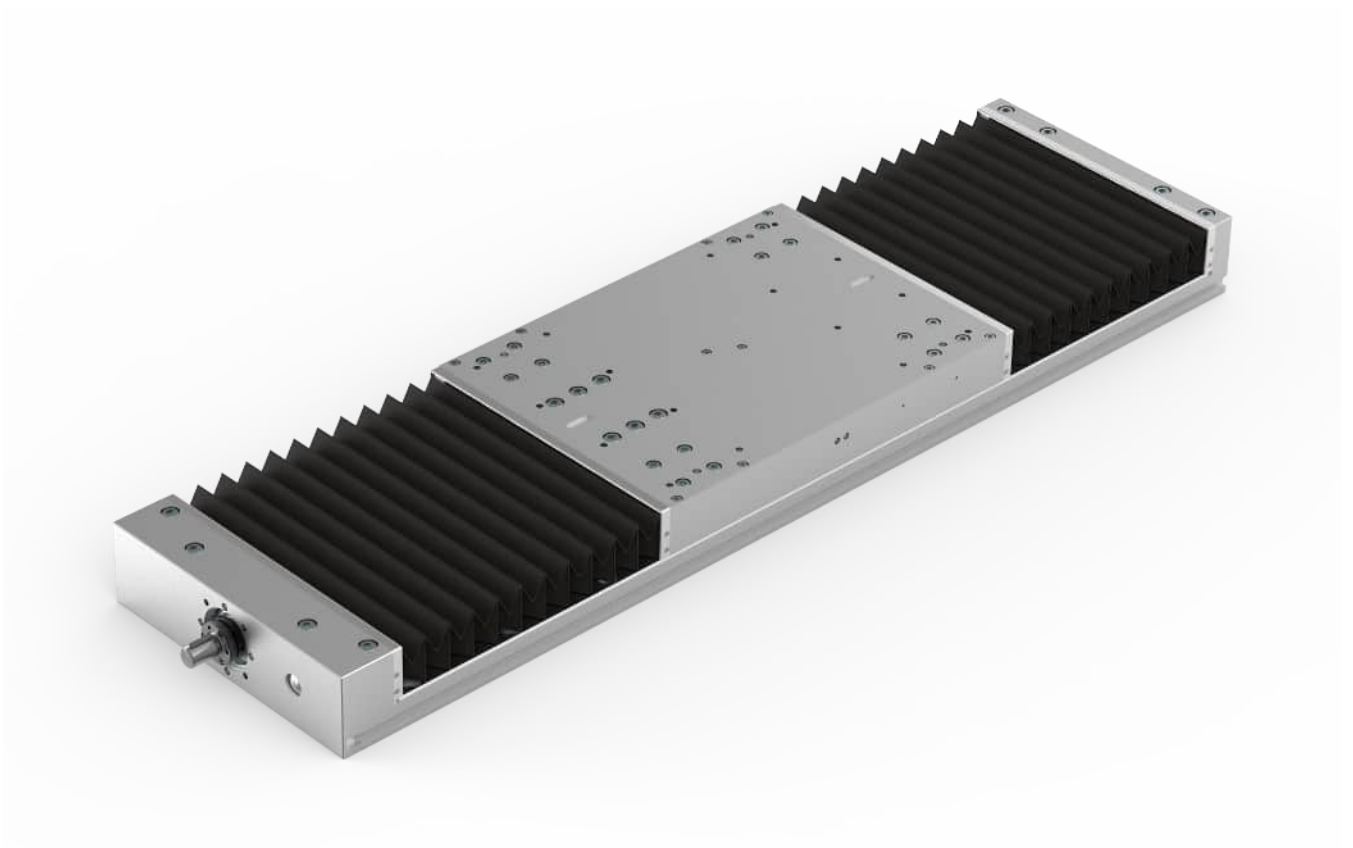

with ball screw (KGT) and double linear guide (SSS)

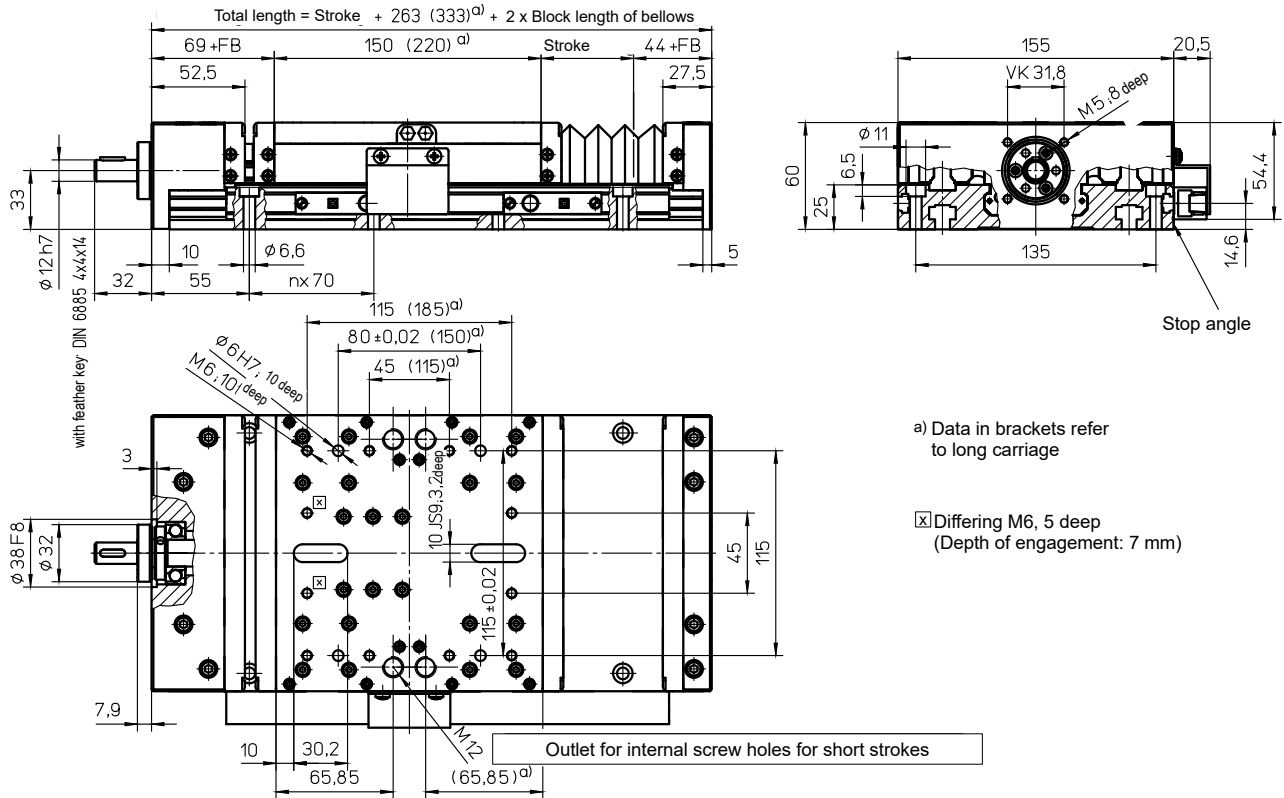

Weights

SSS

Basic length without stroke:	7.80 kg
100 mm stroke:	0.95 kg
Entire carriage 150 mm:	2.80 kg
Entire carriage 220 mm:	4.10 kg
Max. total length:	1500 mm

Technical Data

SSS

Max. total speed:	2.50 m/s
Max. acceleration:	20 m/s ²
Repeat accuracy:	± 0.03 mm (KGT)
Idle torque:	0.35 Nm

Forces and moments

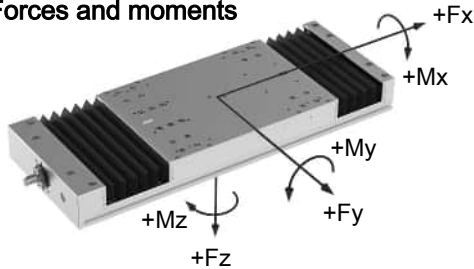

Forces	Dynamic [N]
F _x	4000
F _y	2000
F _z	20000
-F _z	15000
Moments	Dynamic [Nm]
M _x	1000
M _y	900 (1300)
M _z	400 (580)

Data in brackets refer to long carriage (220)

Drive element

KGT

Max. rotation speed:	3000 min ⁻¹
Diameter:	20 mm
Pitch:	5 / 10 / 20 / 50 mm
Moment of inertia:	8.40 • 10 ⁻⁵ kgm ² /m

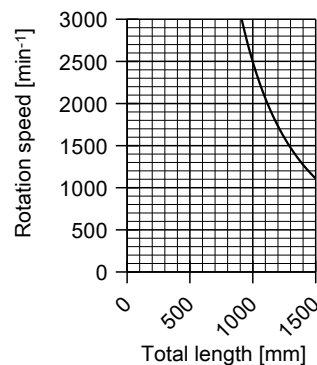

Calculation of block length of bellows (FB)

Stroke / 22 = Number of pleats
 Number of pleats • 3 - 2 = Block length of bellows (FB)

Example for stroke of 500 mm:

500 mm / 22 = 22.73 => 23 pleats (rounded up)
 23 • 3 - 2 = 67 mm simple block length (FB)

with ball screw (KGT) and double linear guide (SSS)

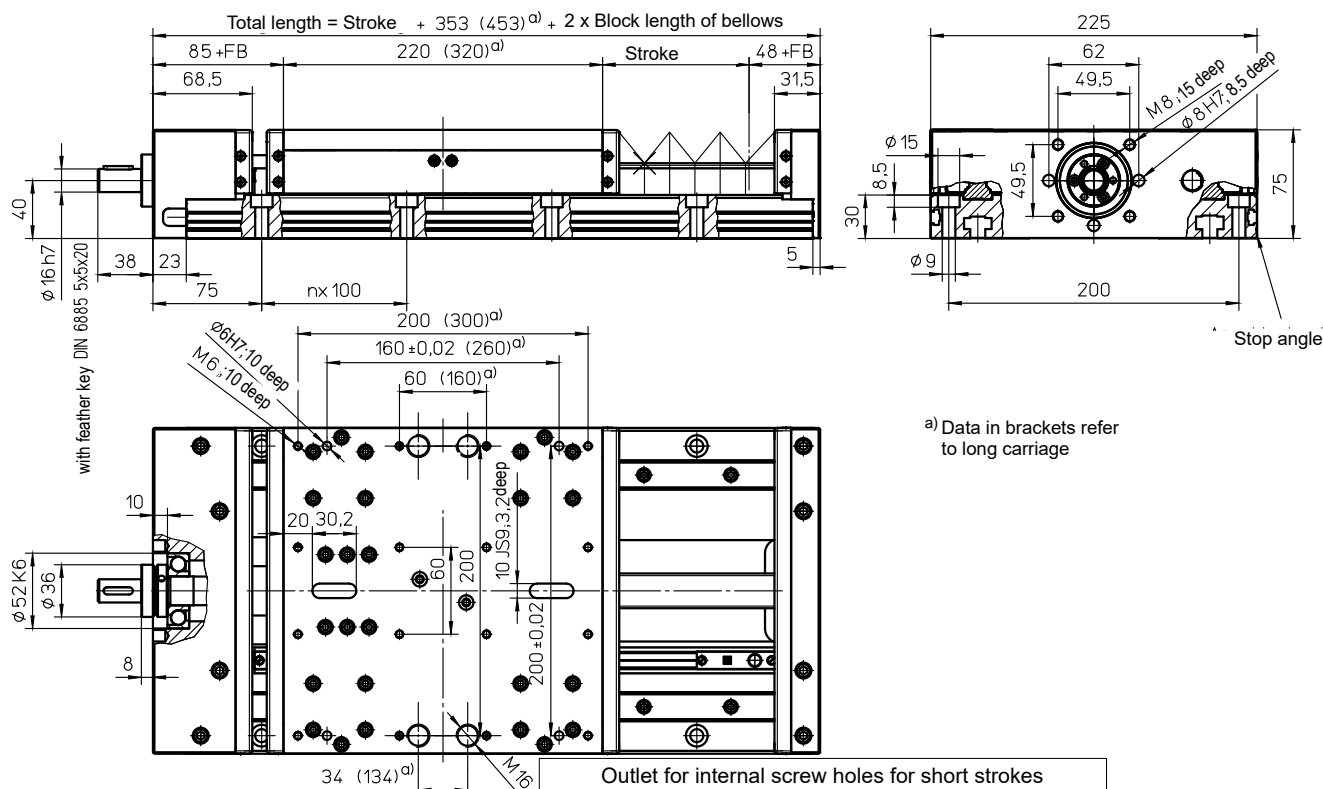

Weights

	SSS
Basic length without stroke:	17.60 kg
100 mm stroke:	2.70 kg
Entire carriage 220 mm:	6.20 kg
Entire carriage 320 mm:	9.00 kg
Max. total length:	2000 mm

Technical Data

	SSS
Max. total speed:	2.50 m/s
Max. acceleration:	20 m/s ²
Repeat accuracy:	± 0.03 mm (KGT)
Idle torque:	1.20 Nm

Forces and moments

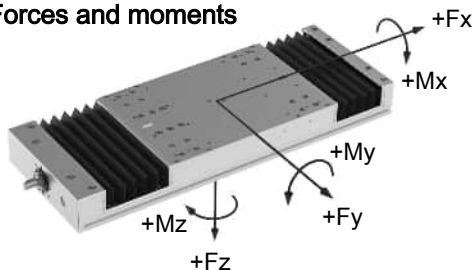

	SSS
Forces	Dynamic [N]
F_x	6000
F_y	5000
F_z	58000
-F_z	40000
Moments	Dynamic [Nm]
M_x	4000
M_y	3000 (4000)
M_z	1200 (1700)

Data in brackets refer to long carriage (320)

Drive element

	KGT
Max. rotation speed:	3000 min ⁻¹
Diameter:	25 mm
Pitch:	5 / 10 / 25 / 50 mm
Moment of inertia:	$2.25 \cdot 10^{-4}$ kgm ² /m

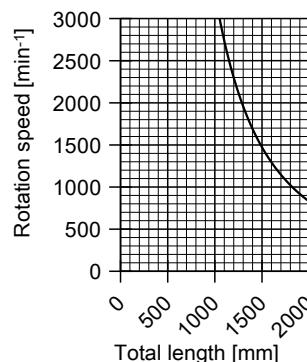

Calculation of block length of bellows (FB)

Stroke / 32 = Number of pleats
 Number of pleats • 3 – 2 = Block length of bellows (FB)

Example for stroke of 500 mm:

500 mm / 32 = 15.62 => 16 pleats (rounded up)
 16 • 3 – 2 = 46 mm simple block length (FB)

with ball screw (KGT) and double linear guide (SSS)

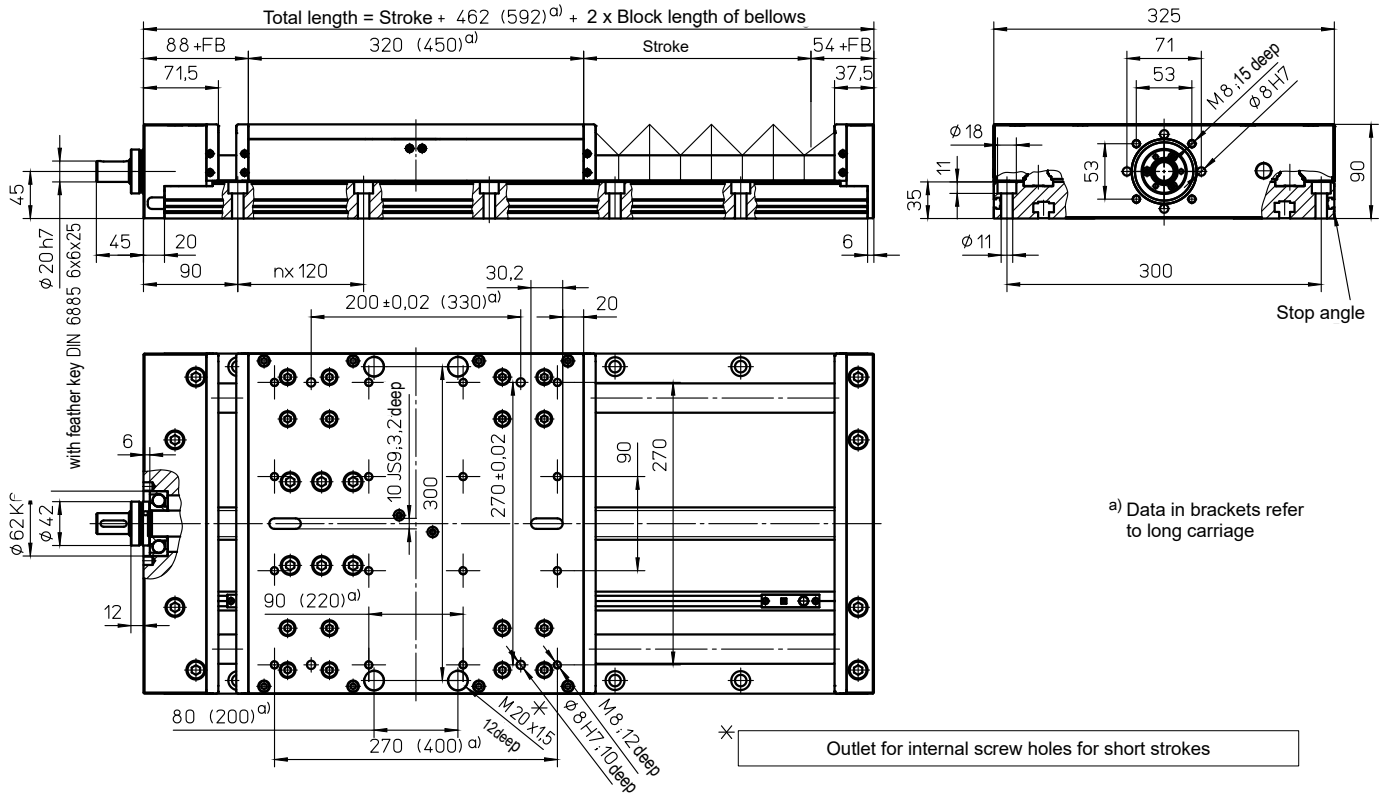

Weights

SSS

Basic length without stroke:	37.00 kg
100 mm stroke:	3.80 kg
Entire carriage 320 mm:	13.40 kg
Entire carriage 450 mm:	18.80 kg
Max. total length:	3000 mm

Technical Data

SSS

Max. total speed:	2.00 m/s
Max. acceleration:	20 m/s ²
Repeat accuracy:	± 0.03 mm (KGT)
Idle torque:	1.60 Nm

Forces and moments

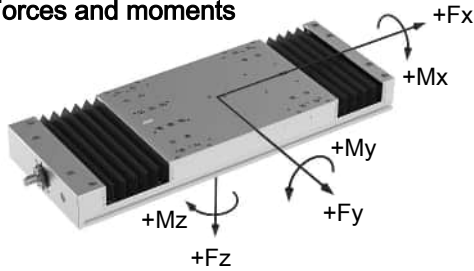

Forces	SSS Dynamic [N]
F _x	12000 *
F _y	11000
F _z	95000
-F _z	63000
Moments	Dynamic [Nm]
M _x	6300
M _y	7500 (9500)
M _z	3750 (5000)

* For KGT 3240: 8000 N

Data in brackets refer to long carriage (450)

Drive element

KGT

Max. rotation speed:	3000 min ⁻¹
Diameter:	32 mm
Pitch:	5 / 10 / 20 / 40 mm
Moment of inertia:	6.39 • 10 ⁻⁴ kgm ² /m

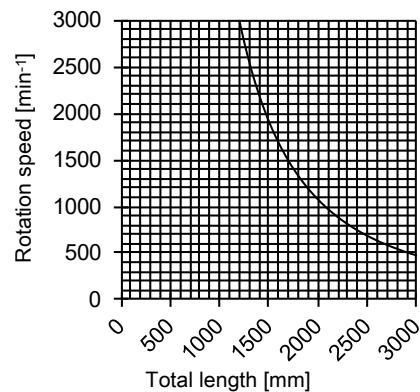

Calculation of block length of bellows (FB)

Example for stroke of 500 mm:

Stroke / 42 = Number of pleats
 Number of pleats • 3 - 2 = Block length of bellows (FB)

500 mm / 42 = 11.90 => 12 pleats (rounded up)
 12 • 3 - 2 = 34 mm simple block length (FB)

* for KGT 3240: 8000 N

with ball screw (KGT) and double linear guide (SSS)

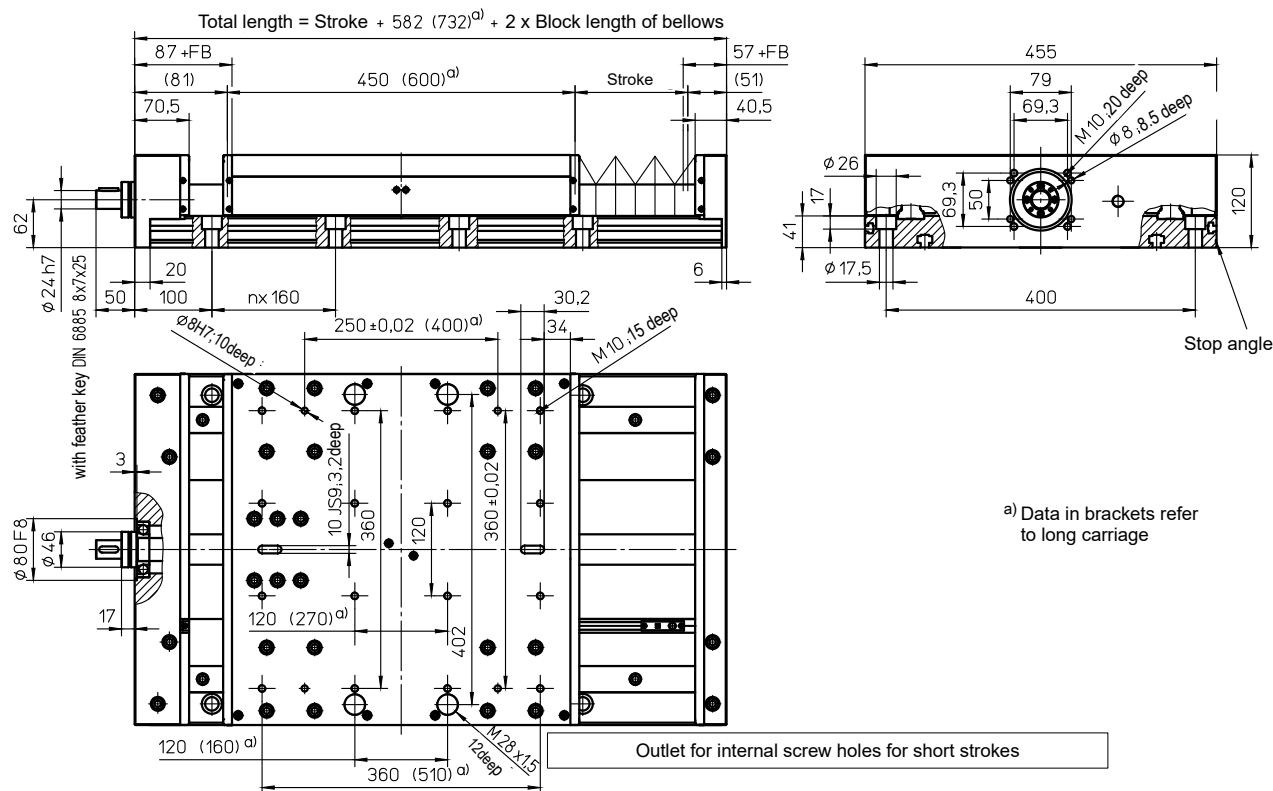

a) Data in brackets refer to long carriage

Weights	SSS
Basic length without stroke:	65.20 kg
100 mm stroke:	5.20 kg
Entire carriage 450 mm:	26.20 kg
Entire carriage 600 mm:	33.80 kg
Max. total length:	3000 mm

Technical Data	SSS
Max. total speed:	2.00 m/s
Max. acceleration:	20 m/s ²
Repeat accuracy:	± 0.03 mm (KGT)
Idle torque:	2.50 Nm

Forces and moments

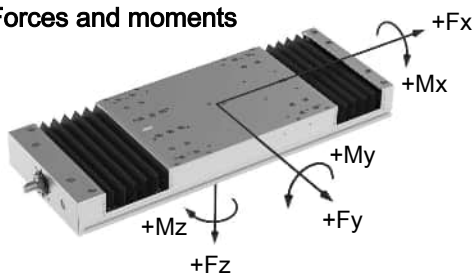

	SSS
Forces	Dynamic [N]
F_x	18000
F_y	14000
F_z	120000
-F_z	80000
Moments	Dynamic [Nm]
M_x	12000
M_y	10000 (13000)
M_z	5000 (6000)

Data in brackets refer to long carriage (600)

Drive element

Drive element	KGT
Max. rotation speed:	3000 min ⁻¹
Diameter:	40 mm
Pitch:	5 / 10 / 20 / 40 mm
Moment of inertia:	1.34 · 10 ⁻³ kgm ² /m

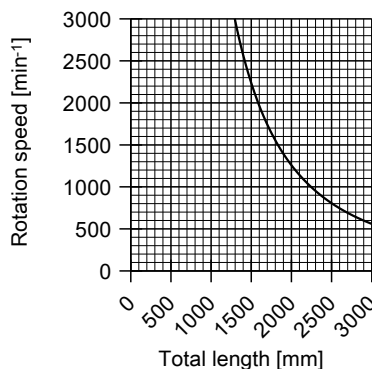

Calculation of block length of bellows (FB)

Stroke / 52 = Number of pleats
 Number of pleats · 3 - 2 = Block length of bellows (FB)

Example for stroke of 500 mm:

500 mm / 52 = 9.62 => 10 pleats (rounded up)
 10 · 3 - 2 = 28 mm simple block length (FB)

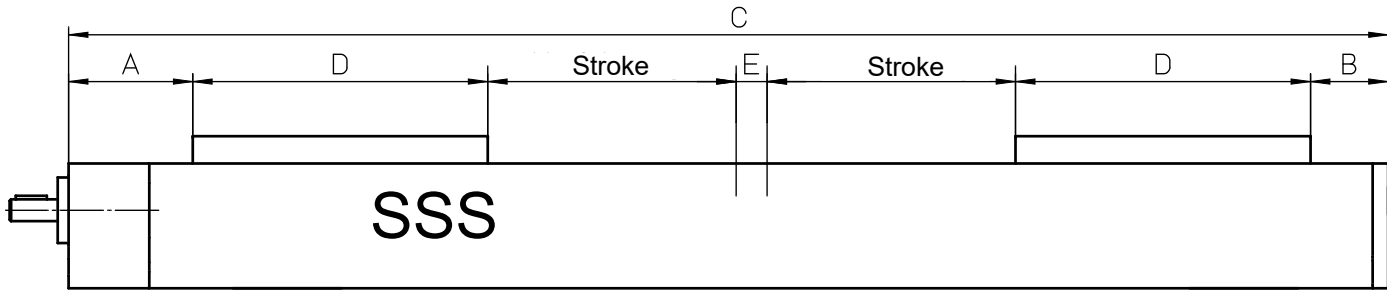

Unit size	A [mm]	B [mm]	Total length C* [mm]	D [mm]	E [mm]	Screw drive ^{b)}
Alpha 15-B-155	69 + FB	44 + FB	2 x stroke + 413 (553) ^{a)} + E 2 · FB + FB _M	150 (220) ^{a)}	FB _M	KGT 2005 or Tr 20x4
Alpha 20-B-225	85 + FB	48 + FB	2 x stroke + 573 (773) ^{a)} + E 2 · FB + FB _M	220 (320) ^{a)}	FB _M	KGT 2505 or Tr 24x5
Alpha 30-B-325	88 + FB	54 + FB	2 x stroke + 782 (1042) ^{a)} + E 2 · FB + FB _M	320 (450) ^{a)}	FB _M	KGT 3205 or Tr 32x6
Alpha 35-B-455	87 + FB	57 + FB	2 x stroke + 1044 (1344) ^{a)} + E 2 · FB + FB _M	450 (600) ^{a)}	FB _M	KGT 4005/4010 or Tr 40x7

For detailed measurements, see main dimensions sheet for respective size
 * Alpha 15 max. 3000 mm, Alpha 20, 20, 25 max. 4000 mm

- a) Data in brackets apply to long carriage
- b) Load ratings for KGT see table on page TL13

Calculation of the bellows block length 'FB'

stroke/stroke_{Fold}: = number of folds (rounded up)
 number of folds · 3 – 2 = bellows block length (FB)

Calculation of the bellows block length 'FB_M'

(2 · Verfahrweg + 5) / stroke_{Fold} = number of folds (rounded up)
 number of folds · 3 + 29 = bellows block length (FB_M)

Definition:

Stroke_{Fold}: Alpha 15-B-155 = 22
 Alpha 20-B-255 = 32
 Alpha 30-B-325 = 42
 Alpha 35-B-455 = 52

Profile Alpha-15-B-155

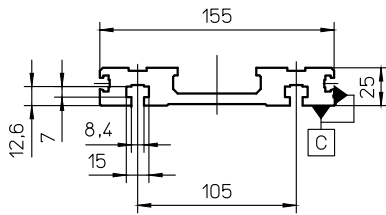

Specific mass [kg/m]	6.42
Surface measure [mm ²]	2377
Geometrical moment of inertia I _y [mm ⁴]	133830
Geometrical moment of inertia I _z [mm ⁴]	5816886
Section modulus W _y [mm ³]	9953
Section modulus W _z [mm ³]	74232

Profile Alpha-20-B-225

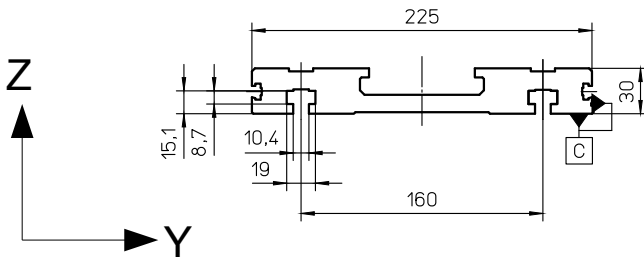

Specific mass [kg/m]	12.54
Surface measure [mm ²]	4644
Geometrical moment of inertia I _y [mm ⁴]	359736
Geometrical moment of inertia I _z [mm ⁴]	22821235
Section modulus W _y [mm ³]	22400
Section modulus W _z [mm ³]	201344

Profile Alpha-30-B-325

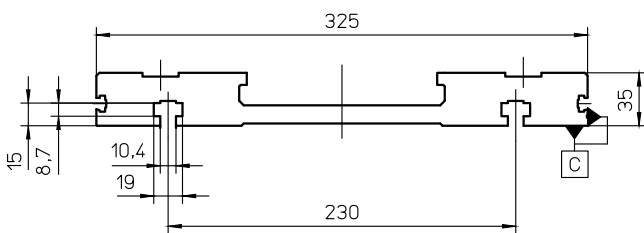

Specific mass [kg/m]	20.56
Surface measure [mm ²]	7615
Geometrical moment of inertia I _y [mm ⁴]	774301
Geometrical moment of inertia I _z [mm ⁴]	84507566
Section modulus W _y [mm ³]	40299
Section modulus W _z [mm ³]	517153

Profile Alpha-35-B-455

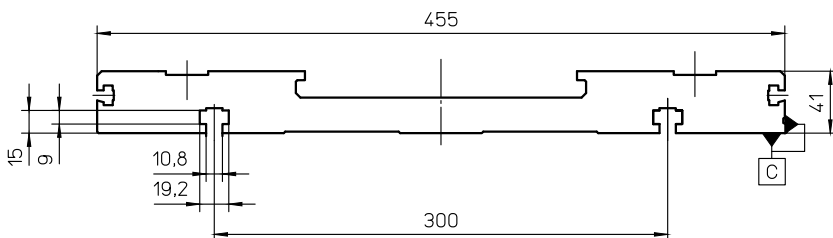

Specific mass [kg/m]	38.73
Surface measure [mm ²]	14346
Geometrical moment of inertia I _y [mm ⁴]	1810370
Geometrical moment of inertia I _z [mm ⁴]	284741450
Section modulus W _y [mm ³]	79280
Section modulus W _z [mm ³]	1243935

Stop angle standard page C

NS 3 / 4 / 6 / 11 NS 4.1 / 10

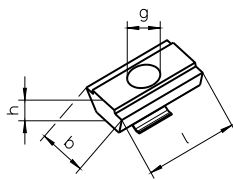
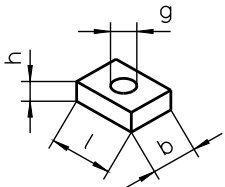

NS 24

RM 4 / 6

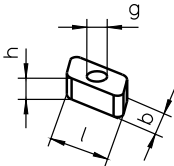
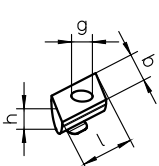

Linear unit	Page *	NS	ID No.	l [mm]	b [mm]	h [mm]	g
Alpha 15-B-155	E	4	10559	18	14	6	M8
		4.1	16552	20	13	6	M8
		10	16499	20	13	6	M6
		RM4	15371	13	8	6	M5
	C and D	11	18784	12	10	3,5	M4
Alpha 20-B-225	E	15	19211	25	18	8	M8
		RM6	15372	18	10	8	M6
	C and D	11	18784	12	10	3,5	M4
Alpha 30-B-325	E	6	10561	25	18	8	M10
		24	16772	25	17	9,5	M10
		RM6	15372	18	10	8	M6
	C and D	11	18784	12	10	3,5	M4
Alpha 35-B-455	E	6	10561	25	18	8	M10
		24	16772	25	17	9,5	M10
		RM6	15372	18	10	8	M6
	C and D	3	10558	20	12	5	M6

* For further information on page C – E, see catalogue page Z1

Example: **Alpha 20-B-225-SSS-M-2505-1000-1660-FB-2EMS-0**

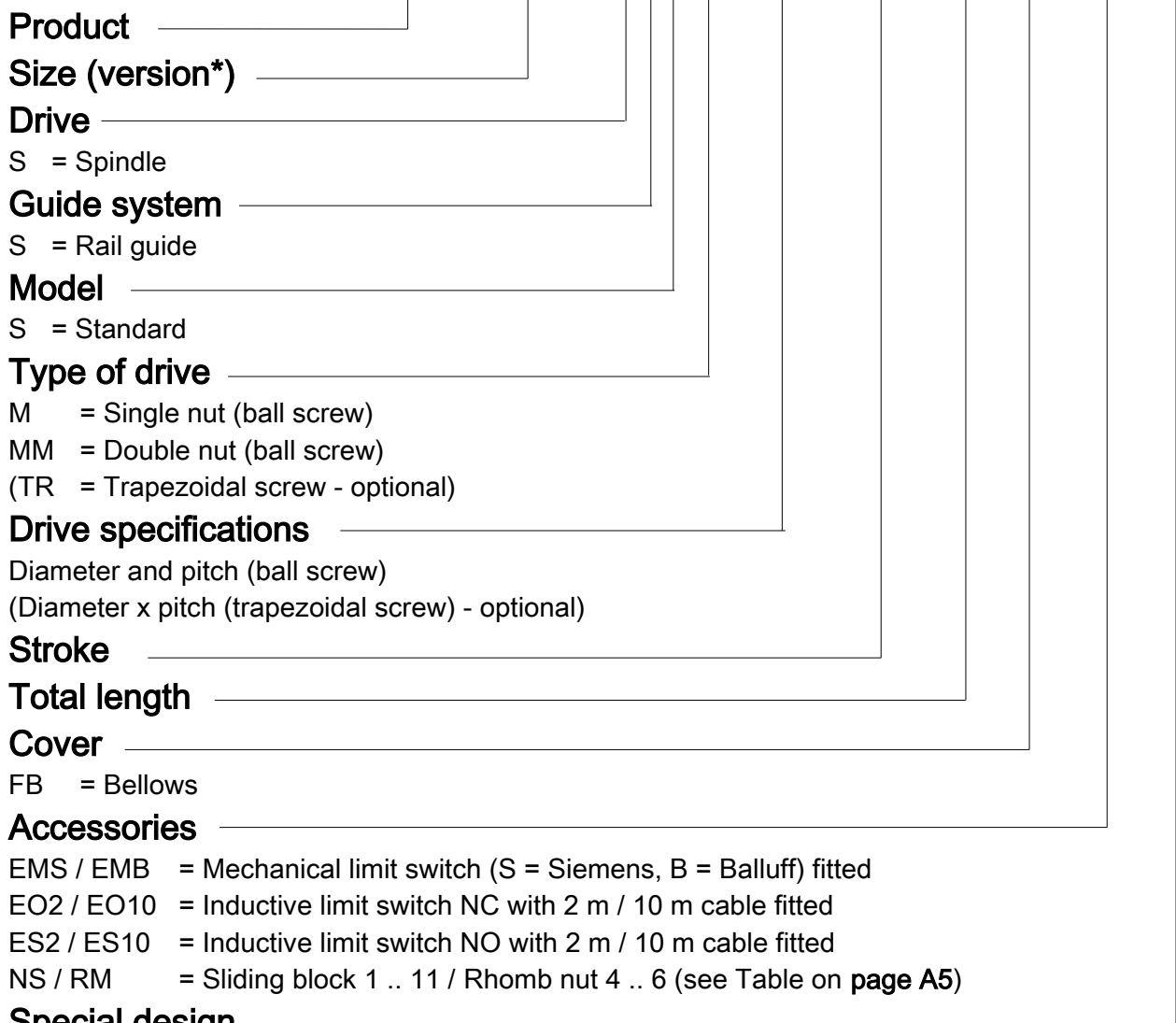

Product

Size (version*)

Drive

S = Spindle

Guide system

S = Rail guide

Model

S = Standard

Type of drive

M = Single nut (ball screw)

MM = Double nut (ball screw)

(TR = Trapezoidal screw - optional)

Drive specifications

Diameter and pitch (ball screw)

(Diameter x pitch (trapezoidal screw) - optional)

Stroke

Total length

Cover

FB = Bellows

Accessories

EMS / EMB = Mechanical limit switch (S = Siemens, B = Balluff) fitted

EO2 / EO10 = Inductive limit switch NC with 2 m / 10 m cable fitted

ES2 / ES10 = Inductive limit switch NO with 2 m / 10 m cable fitted

NS / RM = Sliding block 1 .. 11 / Rhomb nut 4 .. 6 (see Table on **page A5**)

Special design

0 = Standard

1 = Special (add specification description)

Additional accessories (separate position)

MGK = Motor mounting and coupling (according to dimension sheet)

URT = Deflection belt drive (according to dimension sheet)

Further drives available on request:

MK or TK (= single nut made of plastic), KK (= double nut made of plastic)

* currently only version „B“ available

Chapter G

Portal Linear Drive

HSB-gamma[®]

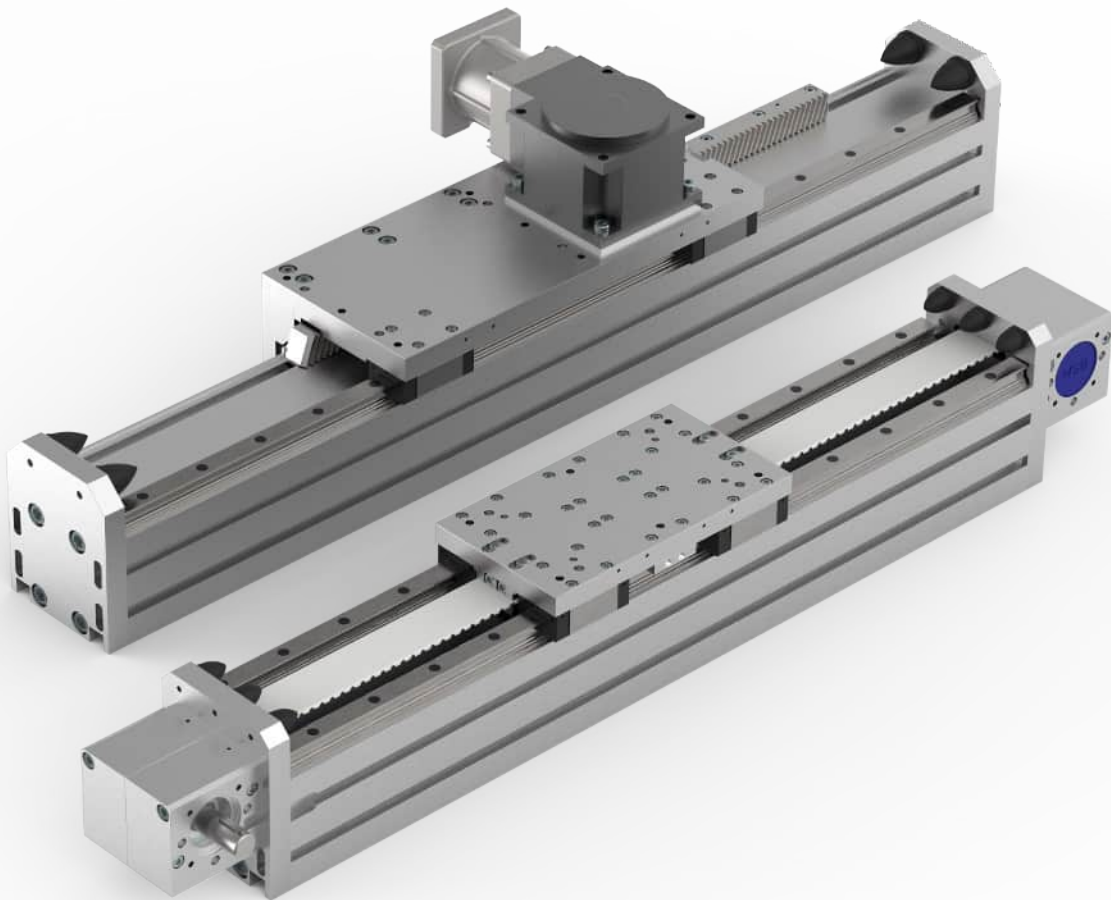

with toothed belt drive and double linear guide (ZSS)

Total length = Stroke + 450 (600)^{a)}

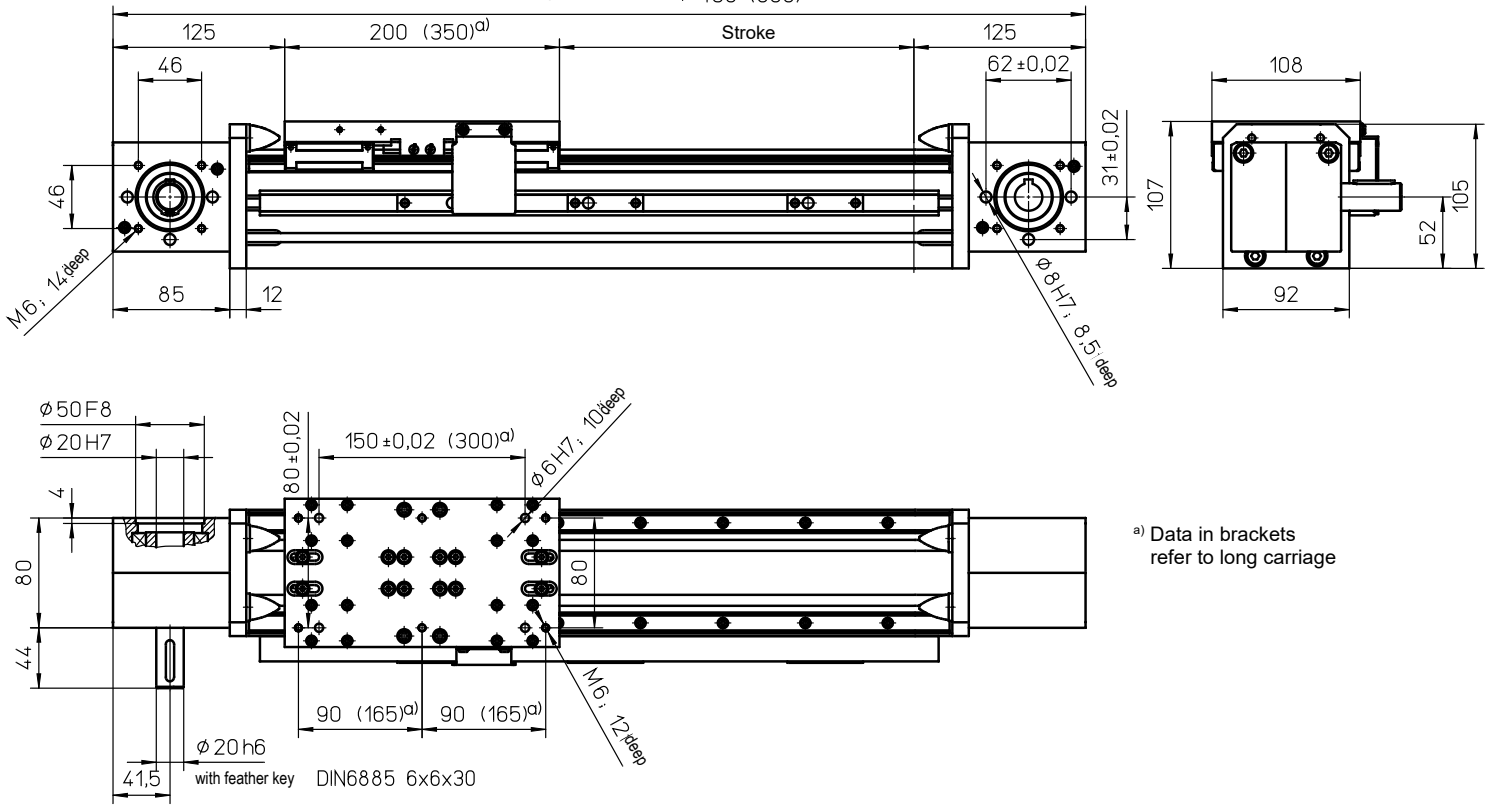

a) Data in brackets refer to long carriage

Weights

ZSS

Basic length without stroke:	10.90 kg
100 mm stroke:	1.00 kg
Entire carriage 200 mm:	2.30 kg
Entire carriage 350 mm:	3.00 kg
Max. total length: (longer on request)	8100 mm

Technical Data

ZSS

Max. speed:	5.00 m/s
Max. acceleration:	60 m/s ²
Repeat accuracy:	± 0.08 mm
Idle torque:	3.20 Nm
Moment of inertia:	3.15 · 10 ⁻³ kgm ²
Drive element:	toothed belt 32 AT10
Stroke per revolution:	210 mm

Forces and moments

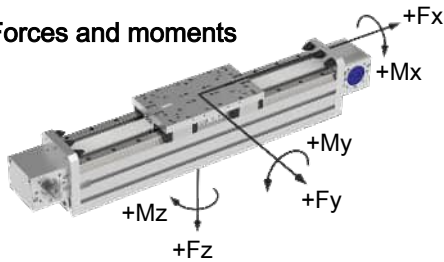

ZSS	
Forces	Dynamic [N]
F _x ^{c)}	2300
F _y	2500
F _z	3000
Moments	dynamic [Nm]
M _x	500
M _y	1200 (2500)
M _z	1000 (2100)

c) Maximum value (see diagram "F_x-v-Diagram")

Data in brackets refer to long carriage (350)

F_x - v - Diagram

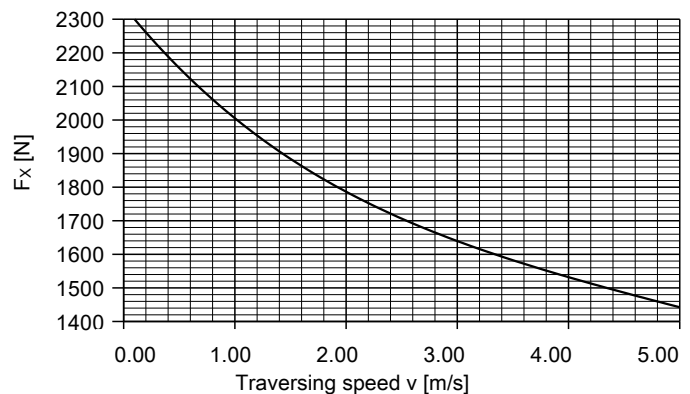

With toothed belt drive and double linear guide a second independently travelling carriage (ZSSD)

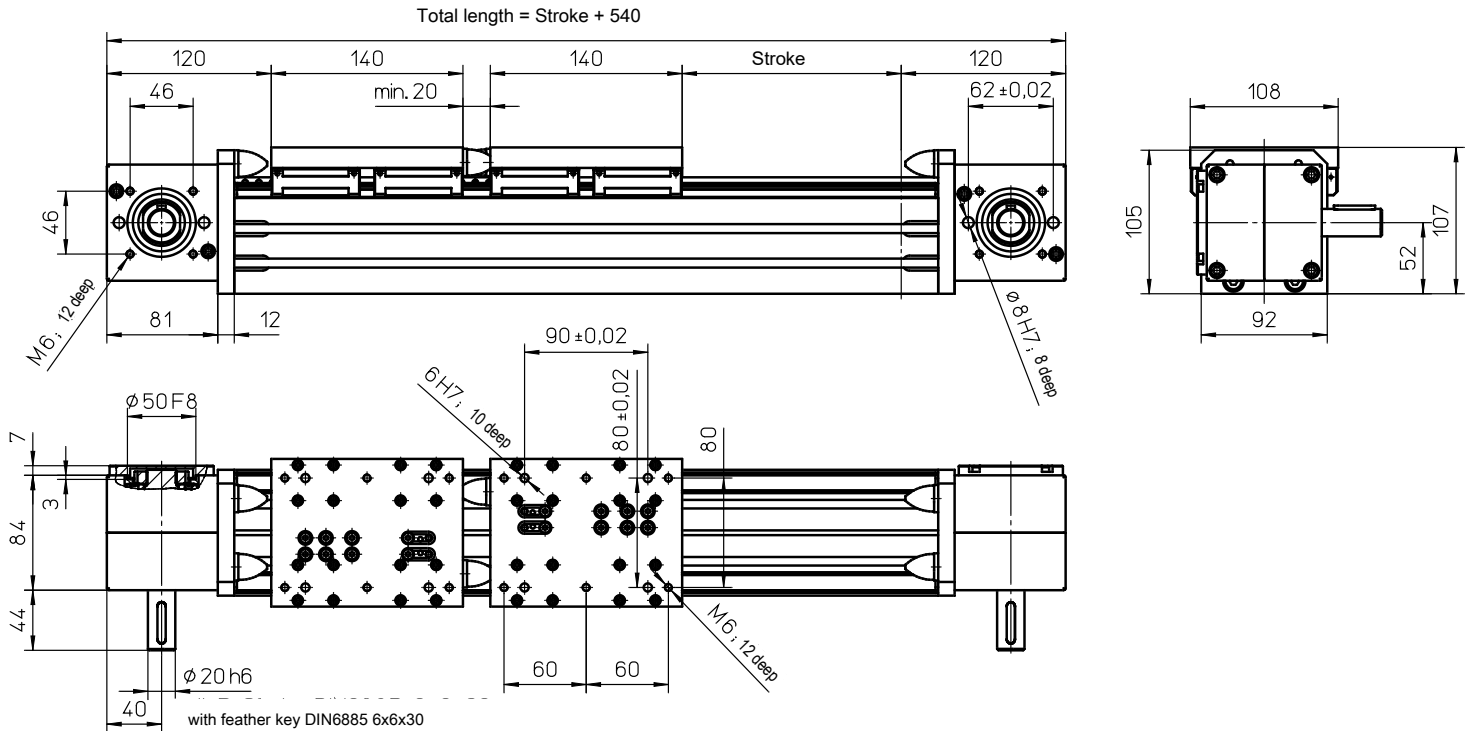

Weights ZSSD

Basic length without stroke:	11.50 kg
100 mm stroke:	1.00 kg
Entire carriage 140 mm:	1.90 kg
Max. total length:	8100 mm
(longer on request)	

Technical Data ZSSD

Max. speed:	5.00 m/s
Max. acceleration:	60 m/s ²
Repeat accuracy:	± 0.08 mm
Idle torque:	2.90 Nm
Moment of inertia:	2.20 · 10 ⁻³ kgm ²
Drive element:	2 x toothed belt 16 AT10
Stroke per revolution:	200 mm

Forces and moments

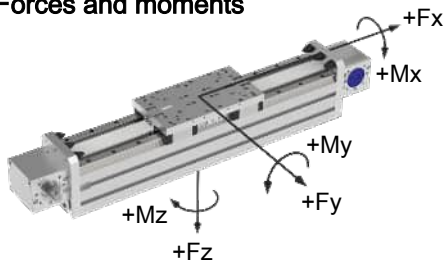

ZSSD	
Forces	Dynamic [N]
F_x^{c)}	1150
F_y	2500
F_z	3000
Moments	Dynamic [Nm]
M_x	400
M_y	1000
M_z	800

^{c)} Maximum value (see diagram "F_x-v-Diagram")

F_x - v - Diagram

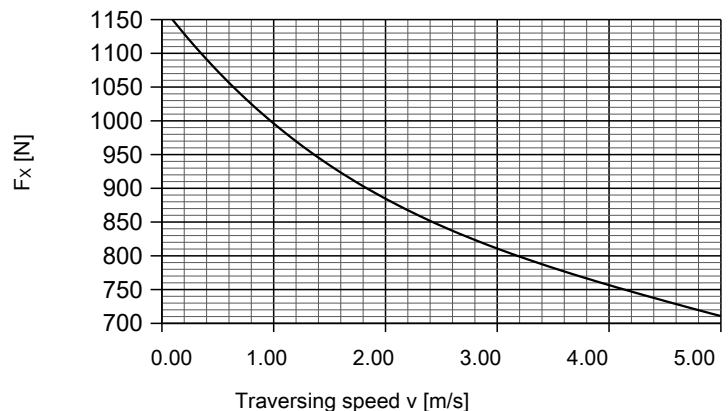

These data apply to each carriage.

with toothed belt drive and double linear guide (ASH)

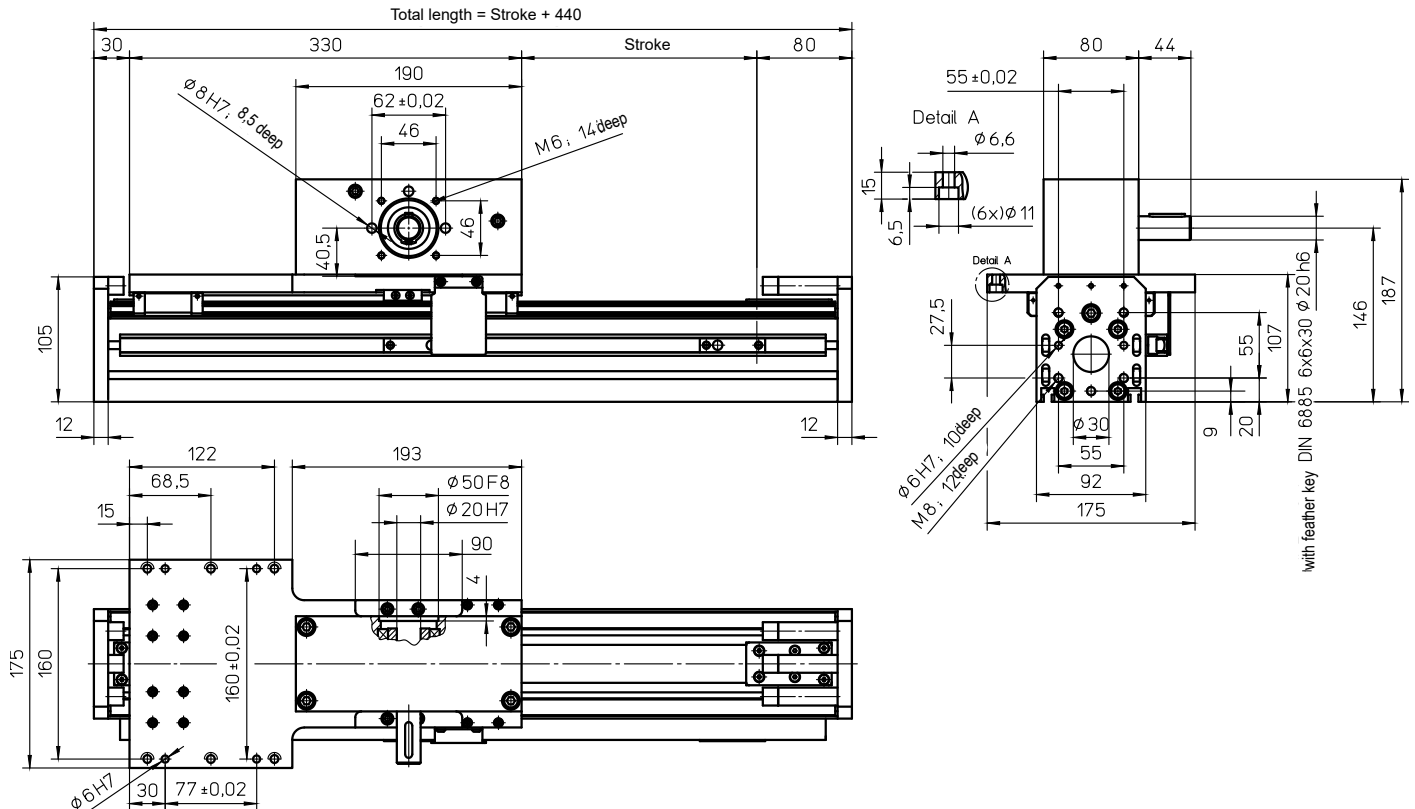

Weights ASH

Basic length without stroke:	11.00 kg
100 mm stroke:	1.00 kg
Entire carriage 330 mm:	6.55 kg
Max. total length: (longer on request)	8000 mm

Technical Data ASH

Max. speed:	5.00 m/s
Max. acceleration:	60 m/s ²
Repeat accuracy:	± 0.08 mm
Idle torque:	3.20 Nm
Moment of inertia: *	7.70 · 10 ⁻³ kgm ²
Drive element:	Toothed belt 32 AT10
Stroke per revolution:	210 mm

Forces and Moments

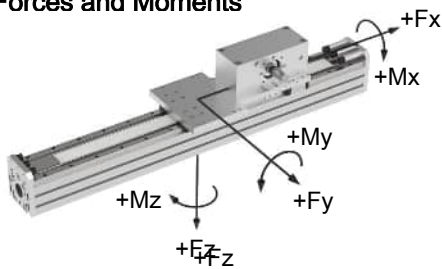

* (entire carriage traverses)

ASH	
Forces	Dynamic [N]
F_x^{c)}	2300
F_y	2500
F_z	3000
Moments	Dynamic [Nm]
M_x	500
M_y	2300
M_z	1900

^{c)} Maximum value (see diagram "F_x-v-Diagram")

F_x - v - Diagram

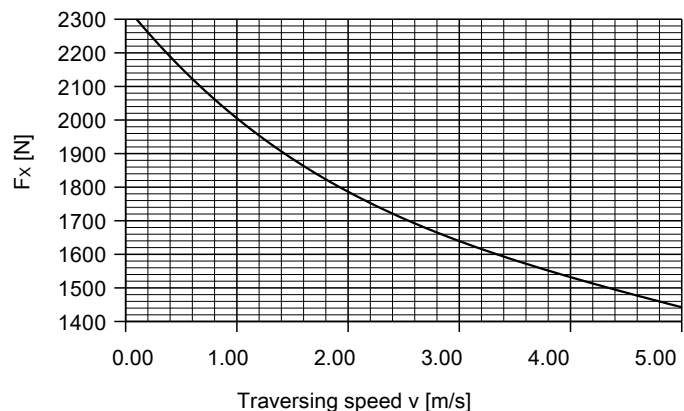

with rack-and-pinion drive (helical) and double linear guide (AZSS)

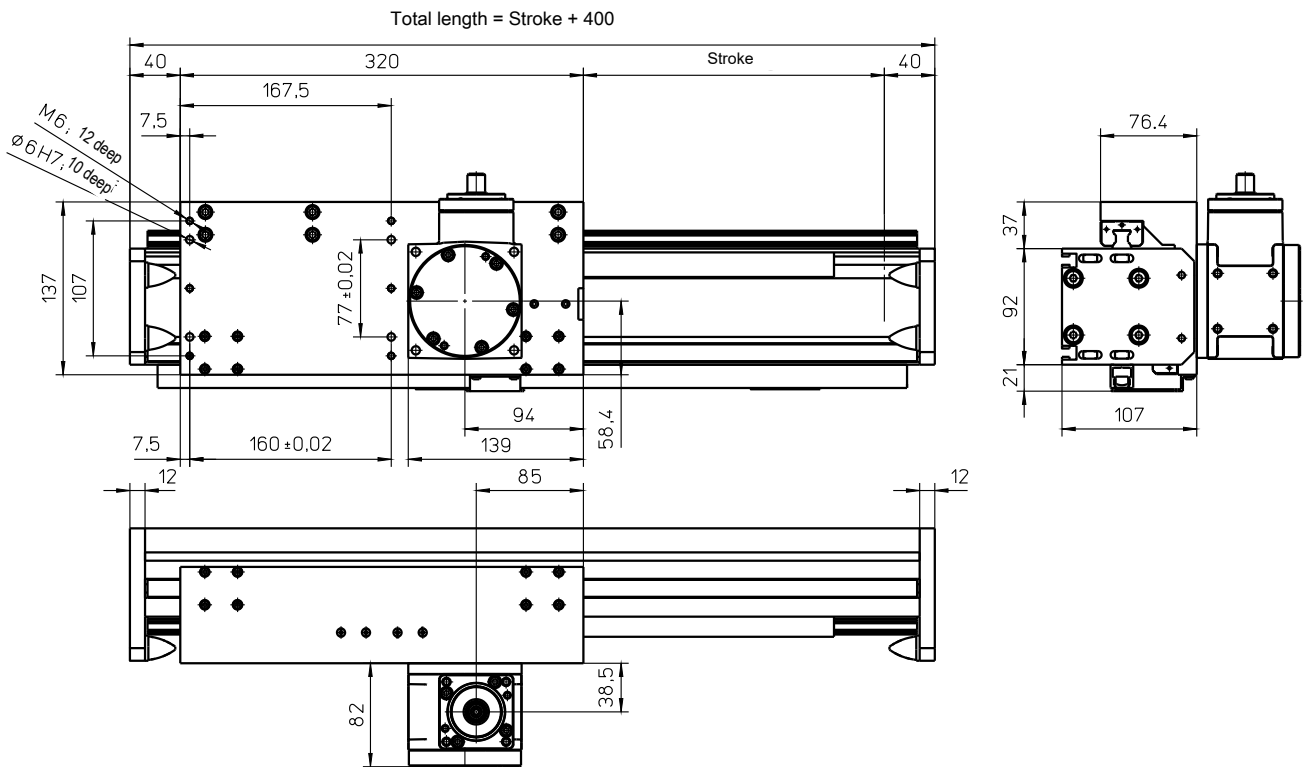

Weights

AZSS

Basic length without stroke:	14.85 kg*
100 mm stroke:	1.30 kg
Carriage 320 mm:	4.20 kg
Gear D55:	3.70 kg

Max. total length: 8000 mm
(longer on request)

Forces and Moments

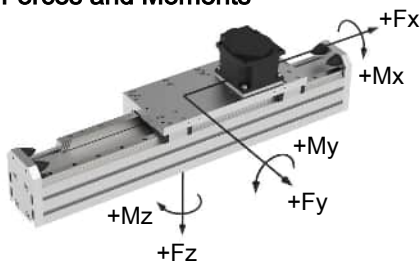

AZSS-D55	
Forces	Dynamic [N]
F_x	1300-1800 **
F_y	3000
F_z	3000
Moments	Dynamic [Nm]
M_x	600
M_y	1800
M_z	1800

Technical Data

AZSS

Max. speed:	3.20 m/s
Max. acceleration:	20 m/s ²
Repeat accuracy:	± 0.05 mm
Idle torque at drive pinion:	2.5 Nm
Rack and pinion:	Module 2 helical
Drive pinion:	Module 2, 18 teeth
Stroke per revolution:	120 mm
Servo-high-performance-gear:	DynaGear D55
Ratios:	5 / 10 / 15

D55	
Force F_x	Dynamic [N]
$i = 5:1$	1800
$i = 10:1$	
$i = 15:1$	1300

Efficiency of gears: > 96 %

Variants for gear mounting see page G29.

* inclusive gear

** depending on gear ratio (see table to right)

with rack-and-pinion drive (helical) and double linear guide (AZSH)

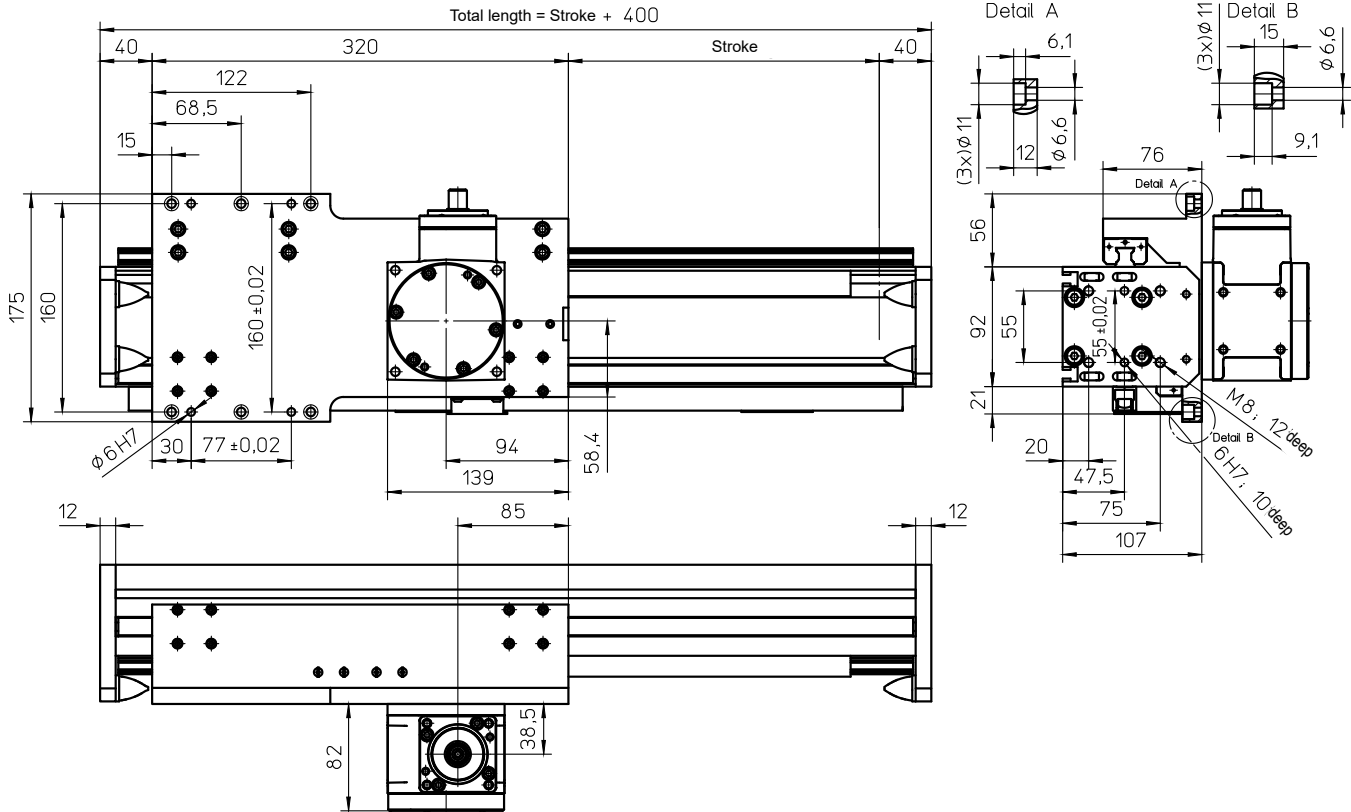

Weights

AZSH

Basic length without stroke:	15.00 kg*
100 mm stroke:	1.30 kg
Carriage 320 mm:	4.35 kg
Gear D55:	3.70 kg

Max. total length: 8000 mm
(longer on request)

Forces and Moments

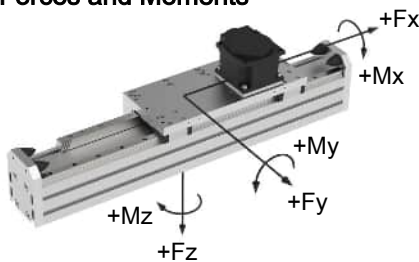

AZSH-D55	
Forces	Dynamic [N]
F_x	1300-1800 **
F_y	3000
F_z	3000
Moments	Dynamic [Nm]
M_x	600
M_y	1800
M_z	1800

Technical Data

AZSH

Max. speed:	3.20 m/s
Max. acceleration:	20 m/s ²
Repeat accuracy:	± 0.05 mm
Idle torque at drive pinion:	2.5 Nm
Rack and pinion:	Modul 2 helical
Drive pinion:	Modul 2, 18 teeth
Stroke per revolution:	120 mm
Servo-high-performance-gear:	DynaGear D55
Ratios:	5 / 10 / 15

D55	
Force F_x	Dynamic [N]
$i = 5:1$	1800
$i = 10:1$	
$i = 15:1$	1300

Efficiency of gears: > 96 %

Variants for gear mounting see page G29.

* inclusive gear

** depending on gear ratio (see table to right)

with toothed belt drive and double linear guide (ZSS)

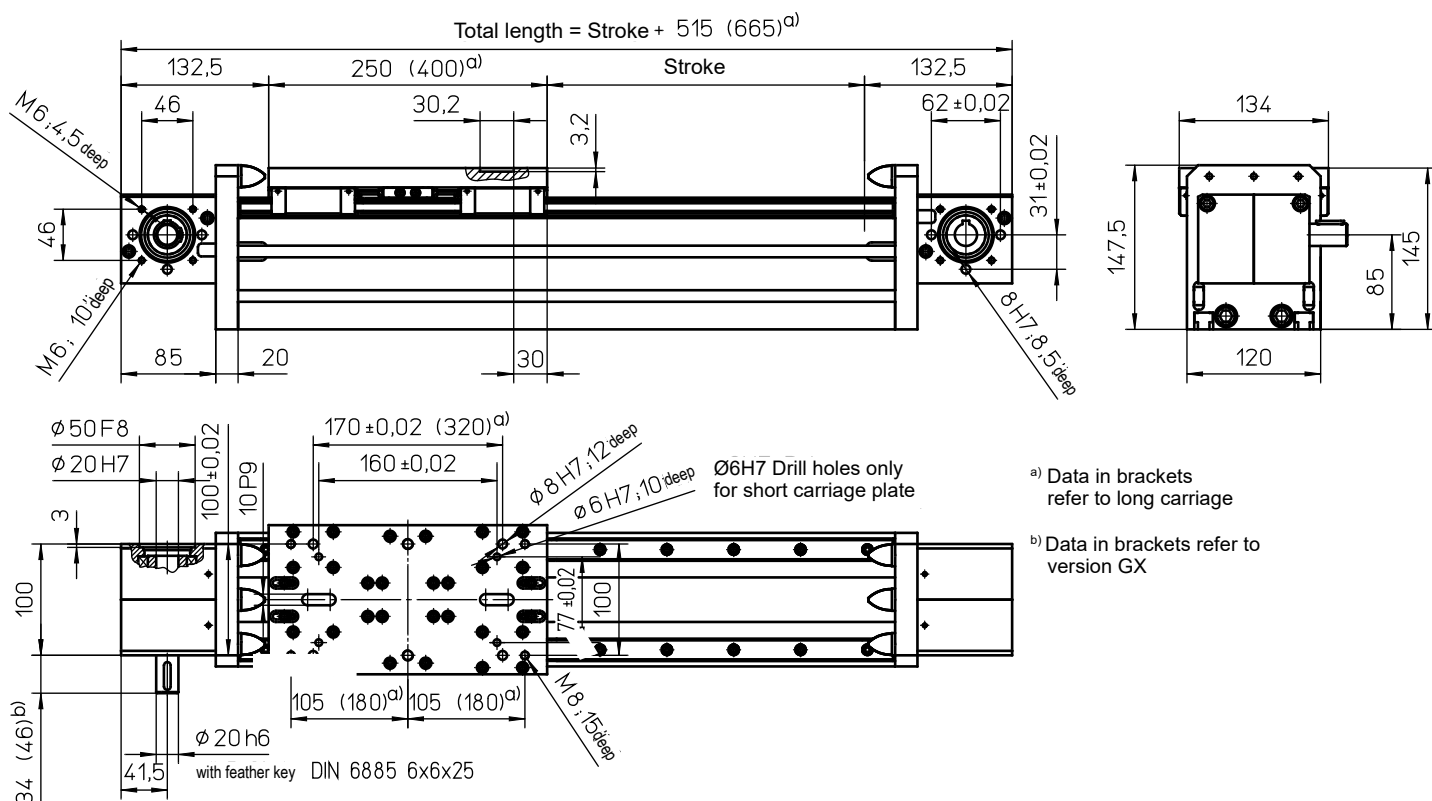

a) Data in brackets refer to long carriage

b) Data in brackets refer to version GX

Weights

ZSS

Basic length without stroke:	19.35 kg
100 mm stroke:	1.65 kg
Entire carriage 250 mm:	4.25 kg
Entire carriage 400 mm:	5.25 kg
Max. total length: (longer on request)	8200 mm

Technical Data

ZSS

Max. speed:	5.00 m/s
Max. acceleration:	60 m/s ²
Repeat accuracy:	± 0.08 mm
Idle torque:	3.00 Nm
Moment of inertia:	4.90 · 10 ⁻³ kgm ²
Drive element:	Toothed belt 40 AT10-E
Stroke per revolution:	200 mm

Forces and moments

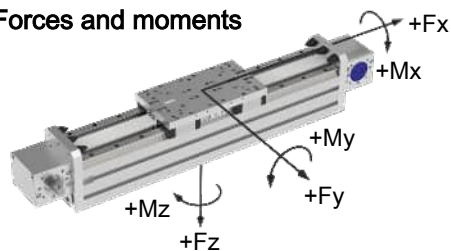

ZSS	
Forces	Dynamic [N]
F_x ^{e)}	2800
F_y	6000
F_z	8000
Moments	Dynamic [Nm]
M_x	1200
M_y	3000 (5000)
M_z	2500 (4200)

^{e)} Maximum value (see diagram "F_x-v-Diagram")
Data in brackets refer to long carriage (400)

F_x - v - Diagram

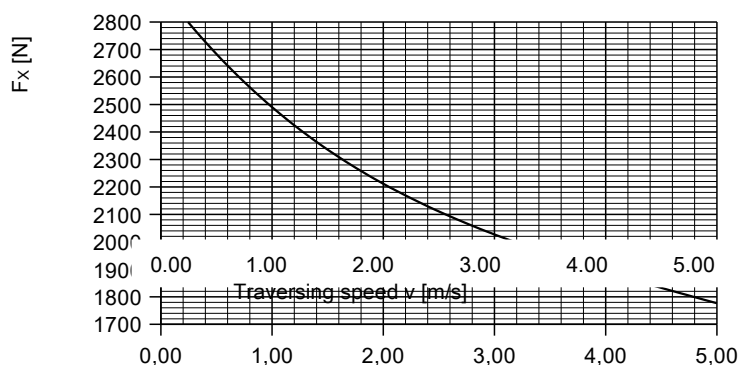

with toothed belt drive and double linear guide and a second independently travelling carriage

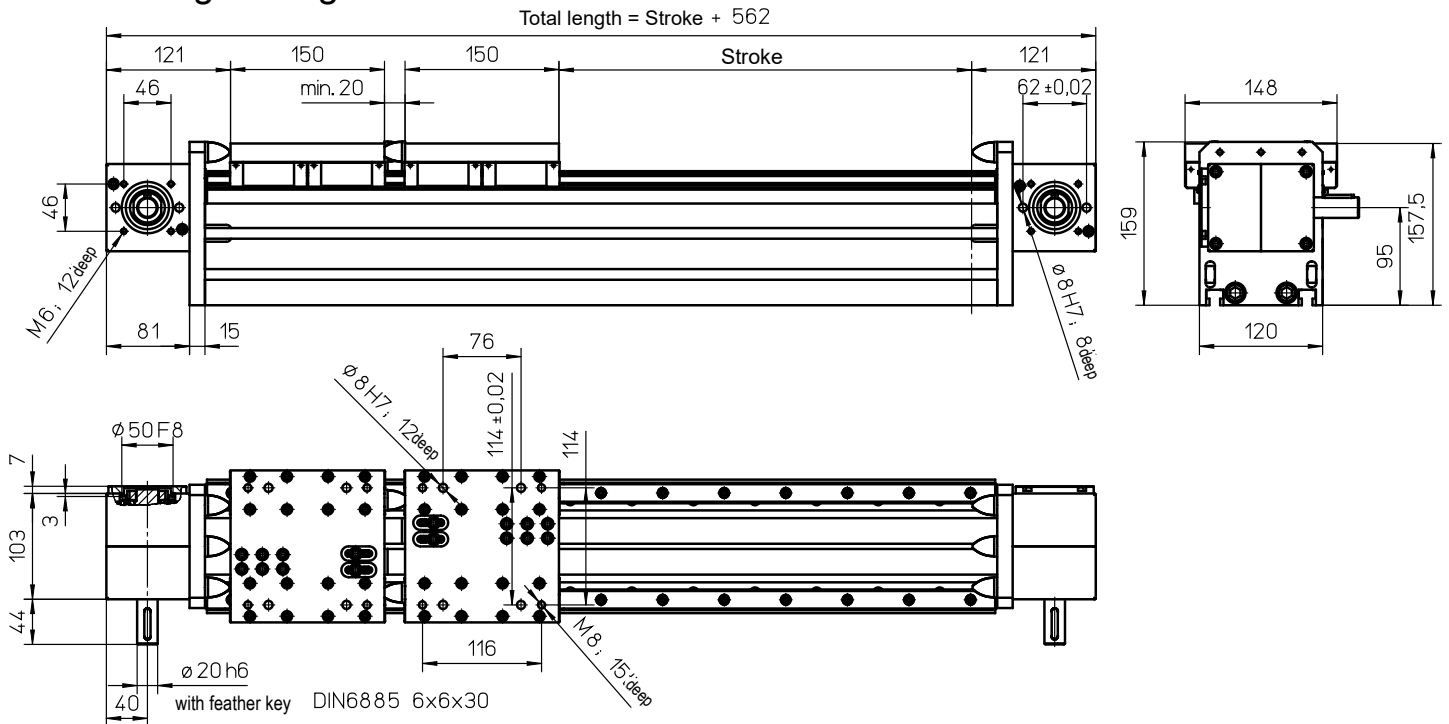

Weights

ZSSD

Basic length without stroke:	19.40 kg
100 mm stroke:	1.90 kg
Entire carriage 150 mm:	3.40 kg
Max. total length: (longer on request)	8200 mm

Technical Data

ZSSD

Max. speed:	5.00 m/s
Max. acceleration:	60 m/s ²
Repeat accuracy:	± 0,08 mm
Idle torque:	3.00 Nm
Moment of inertia:	3.90 • 10 ⁻³ kgm ²
Drive element:	2 x Toothed belt 25 ATL10
Stroke per revolution:	200 mm

Forces and moments

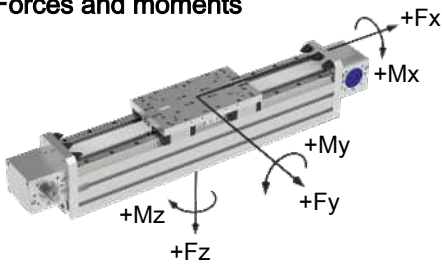

ZSSD	
Forces	Dynamic [N]
F_x^{c)}	1800
F_y	6000
F_z	8000
Moments	Dynamic [Nm]
M_x	1200
M_y	1300
M_z	1100

^{c)} Maximum value (see diagram "F_x-v-Diagram")

F_x - v - Diagram

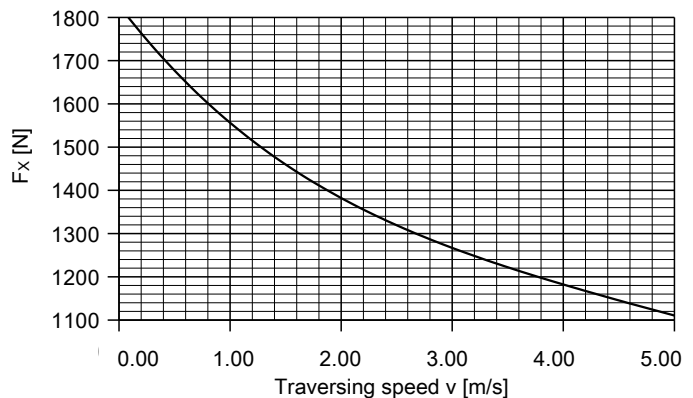

These data apply to each carriage.

with toothed belt drive and double linear guide (ASH)

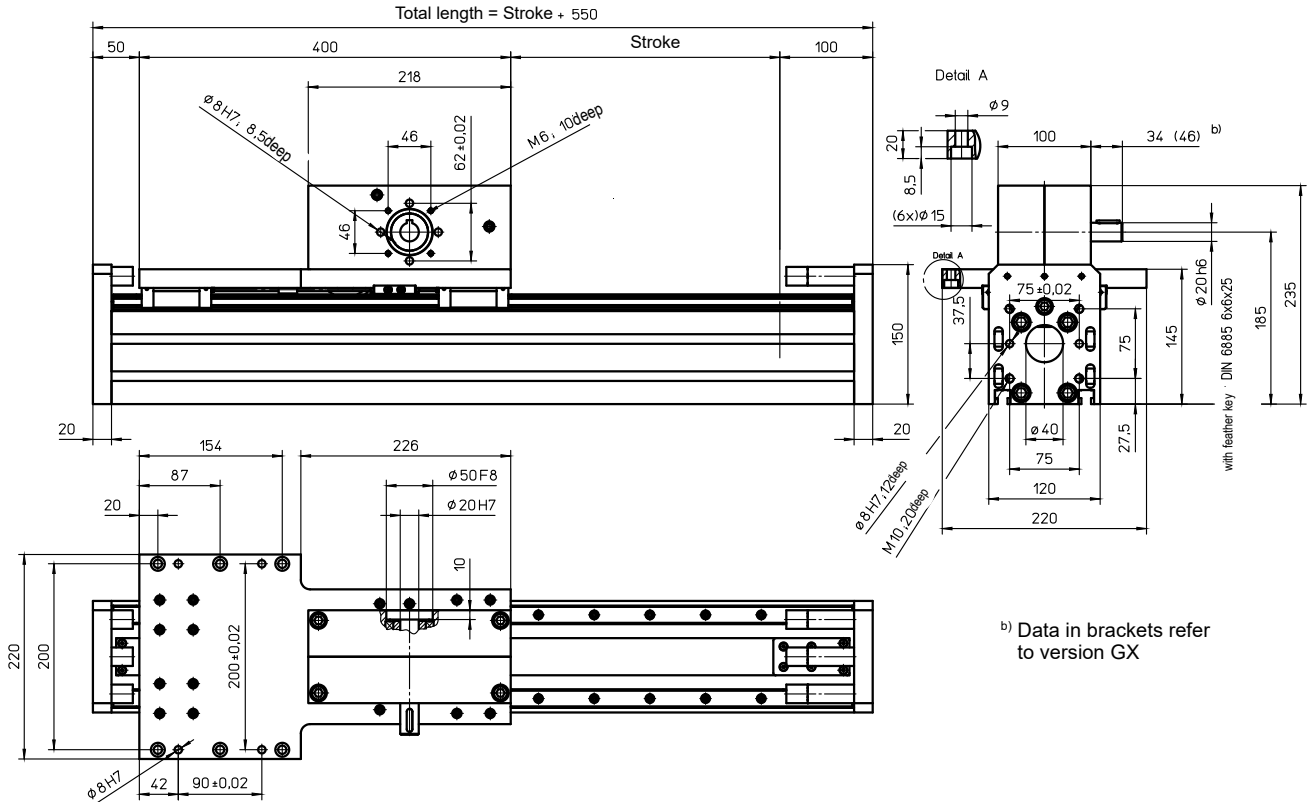

Weights ASH

Basic length without stroke:	21.35 kg
100 mm stroke:	1.65 kg
Entire carriage 400 mm:	10.25 kg

Max. total length: 8000 mm
(longer on request)

Technical Data ASH

Max. speed:	5.00 m/s
Max. acceleration:	60 m/s ²
Repeat accuracy:	± 0.08 mm
Idle torque:	3.60 Nm
Moment of inertia: [*]	1.57 · 10 ⁻² kgm ²
Drive element:	Toothed belt 40 AT10-E
Stroke per revolution:	240 mm

^{*} (entire carriage traverse)

Forces and moments

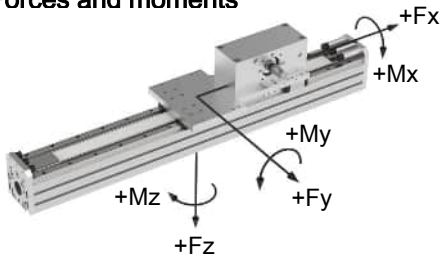

ASH	
Forces	Dynamic [N]
F_x^{c)}	3200
F_y	6000
F_z	8000
Moments	Dynamic [Nm]
M_x	1200
M_y	5000
M_z	4200

^{c)} Maximum value (see diagram "F_x-v-Diagram")

F_x - v - Diagram

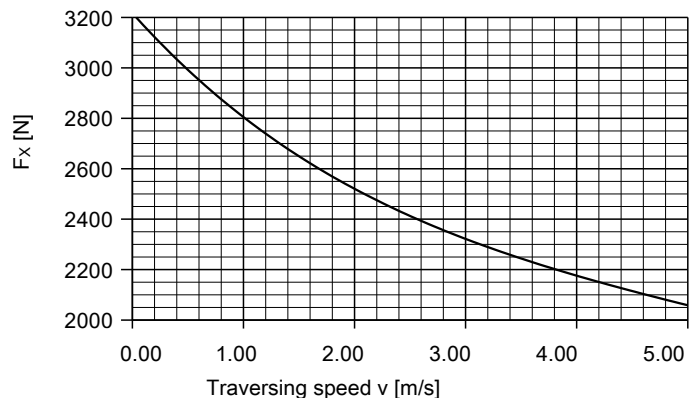

with rack-and-pinion drive (helical) and double linear guide (AZSS)

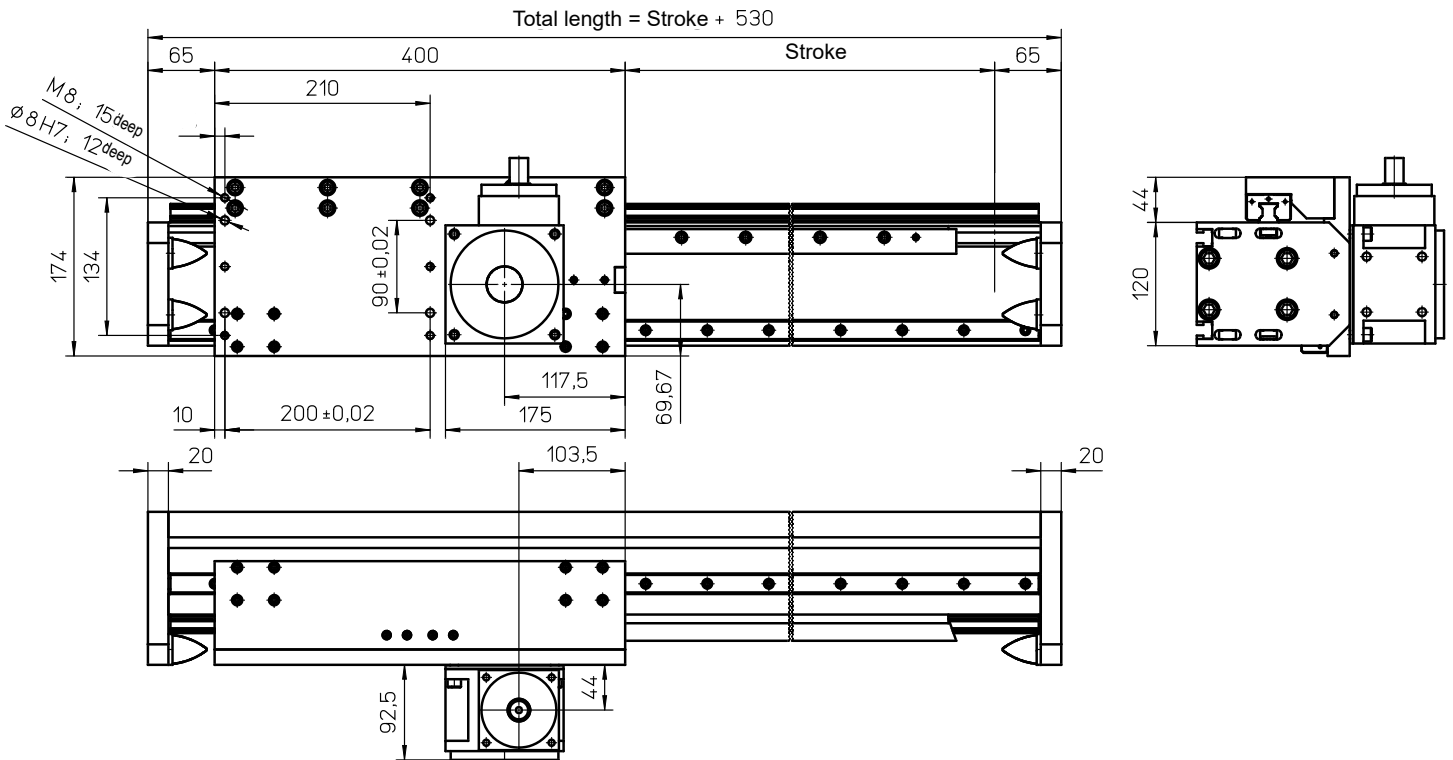

Weights

	AZSS
Basic length without stroke:	25.85 kg*
100 mm stroke:	2.10 kg
Carriage 400 mm:	8.20 kg
Gear D75:	6.30 kg
Max. total length: (longer on request)	8000 mm

Forces and moments

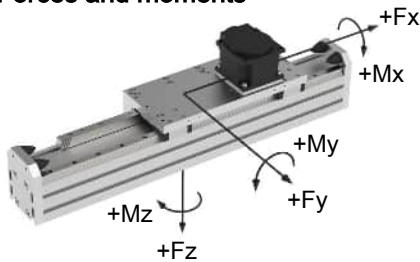

AZSS-D75	
Forces	Dynamic [N]
F_x	1500-2200 **
F_y	8000
F_z	8000
Moments	Dynamic [Nm]
M_x	1500
M_y	4000
M_z	4000

Technical Data

	AZSS
Max. speed:	5.00 m/s
Max. acceleration:	20 m/s ²
Repeat accuracy:	± 0.05 mm
Idle torque at drive pinion:	4.80 Nm
Rack and pinion:	Module 2 helical
Drive pinion:	Module 2, 30 teeth
Stroke per revolution:	200 mm
Servo-high-performance-gear:	DynaGear D75
Ratios:	5 / 10 / 15

D75	
Load F_x	Dynamic [N]
$i = 5:1$	2200
$i = 10:1$	
$i = 15:1$	1500

Efficiency of gears: > 96 %

Variants for gear mounting see page G29.

* inclusive gear

** depending on gear ratio (see table to right)

with rack-and-pinion drive (helical) and double linear guide (AZSH)

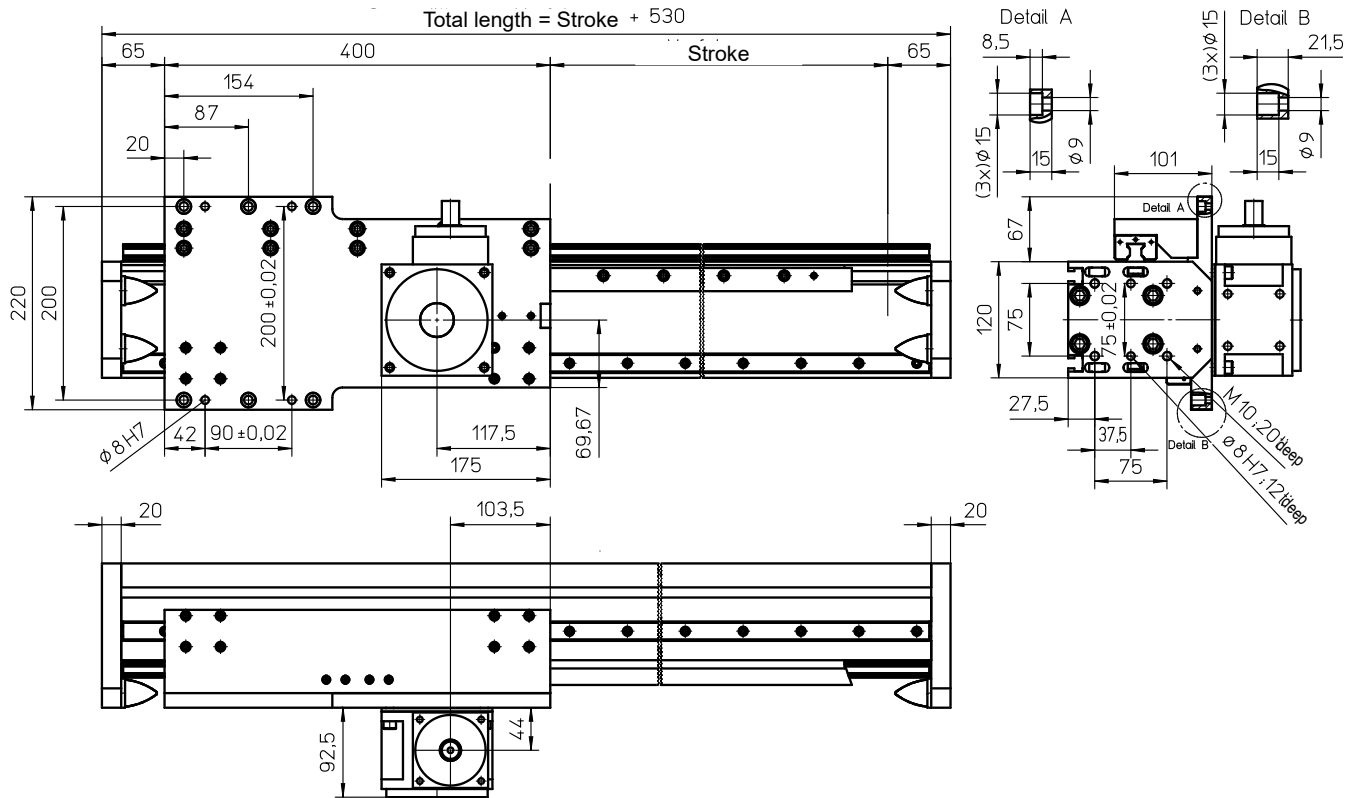

Weights

	AZSH
Basic length without stroke:	26.10 kg*
100 mm stroke:	2.10 kg
Carriage 400 mm:	8.45 kg
Gear D75:	6.30 kg
Max. total length: (longer on request)	8000 mm

Technical Data

	AZSH
Max. speed:	5.00 m/s
Max. acceleration:	20 m/s ²
Repeat accuracy:	± 0.05 mm
Idle torque at drive pinion:	4.80 Nm
Rack and pinion:	Module 2 helical
Drive pinion:	Module 2, 30 teeth
Stroke per revolution:	200 mm
Servo-high-performance-gear:	DynaGear D75
Ratios:	5 / 10 / 15

Forces and moments

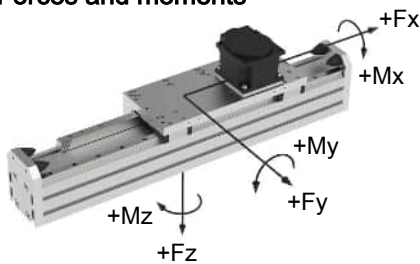

AZSH-D75	
Forces	Dynamic [N]
F_x	1500-2200 **
F_y	8000
F_z	8000
Moments	Dynamic [Nm]
M_x	1500
M_y	4000
M_z	4000

D75	
Load F_x	Dynamic [N]
$i = 5:1$	2200
$i = 10:1$	
$i = 15:1$	1500

Efficiency of gears: > 96 %

Variants for gear mounting see page G29.

* inclusive gear

** depending on gear ratio (see table to right)

with toothed belt drive and double linear guide (ZSS)

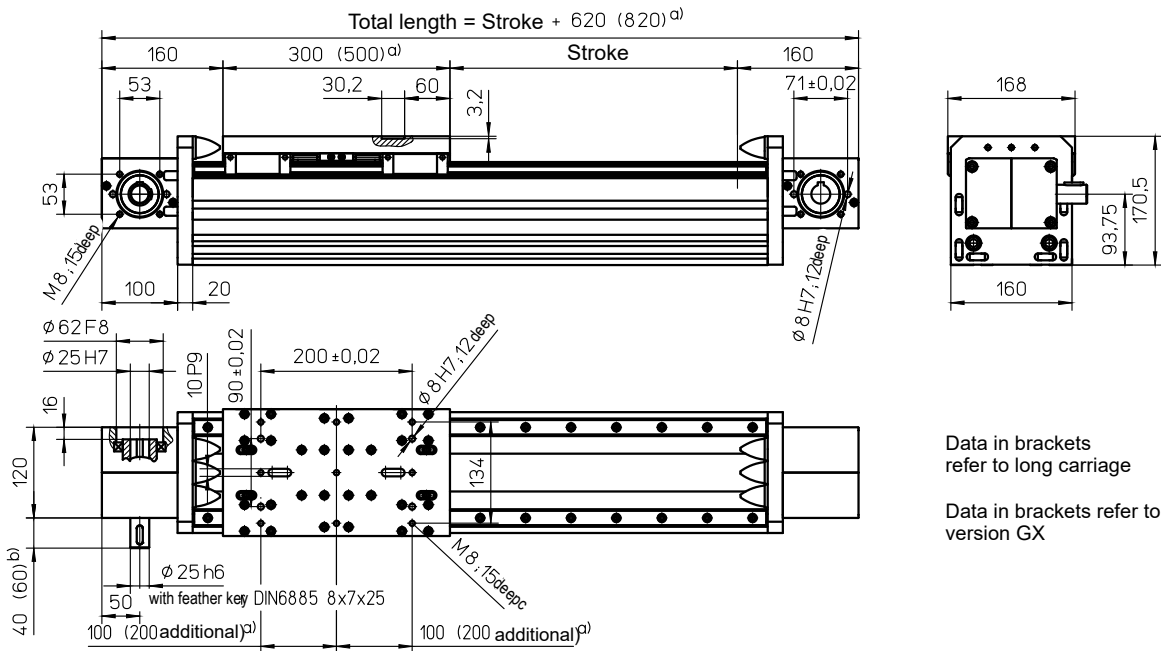

Weights	ZSS
Basic length without stroke:	26.50 kg
100 mm stroke:	2.42 kg
Entire carriage 300 mm:	7.60 kg
Entire carriage 500 mm:	9.80 kg
Max. total length: (longer on request)	8200 mm

Technical Data	ZSS
Max. speed:	5.00 m/s
Max. acceleration:	60 m/s ²
Repeat accuracy:	± 0.08 mm
Idle torque:	4.00 Nm
Moment of inertia:	1.80 · 10 ⁻² kgm ²
Drive element:	Toothed belt 50 ATL10
Stroke per revolution:	240 mm

Forces and moments

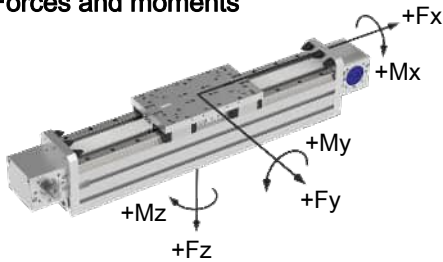

ZSS	
Forces	Dynamic [N]
F _x ^{c)}	4000
F _y	10000
F _z	16000
Moments	Dynamic [Nm]
M _x	1800
M _y	5000 (8000)
M _z	4000 (7000)

^{c)} Maximum value (see diagram "F_x-v-Diagram")
Data in brackets refer to long carriage (500)

F_x - v - Diagram

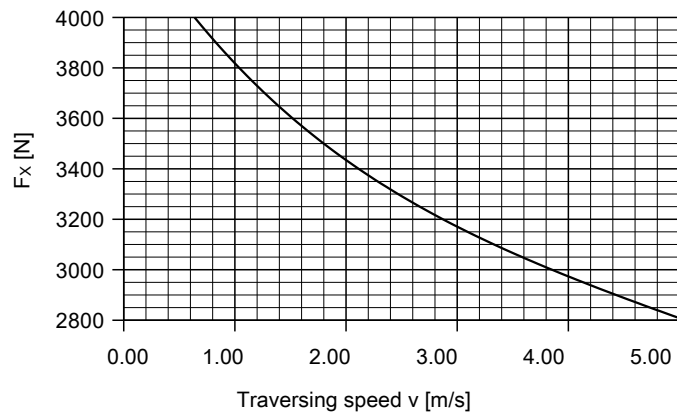

with toothed belt drive and double linear guide and a second independently travelling carriage (ZSSD)

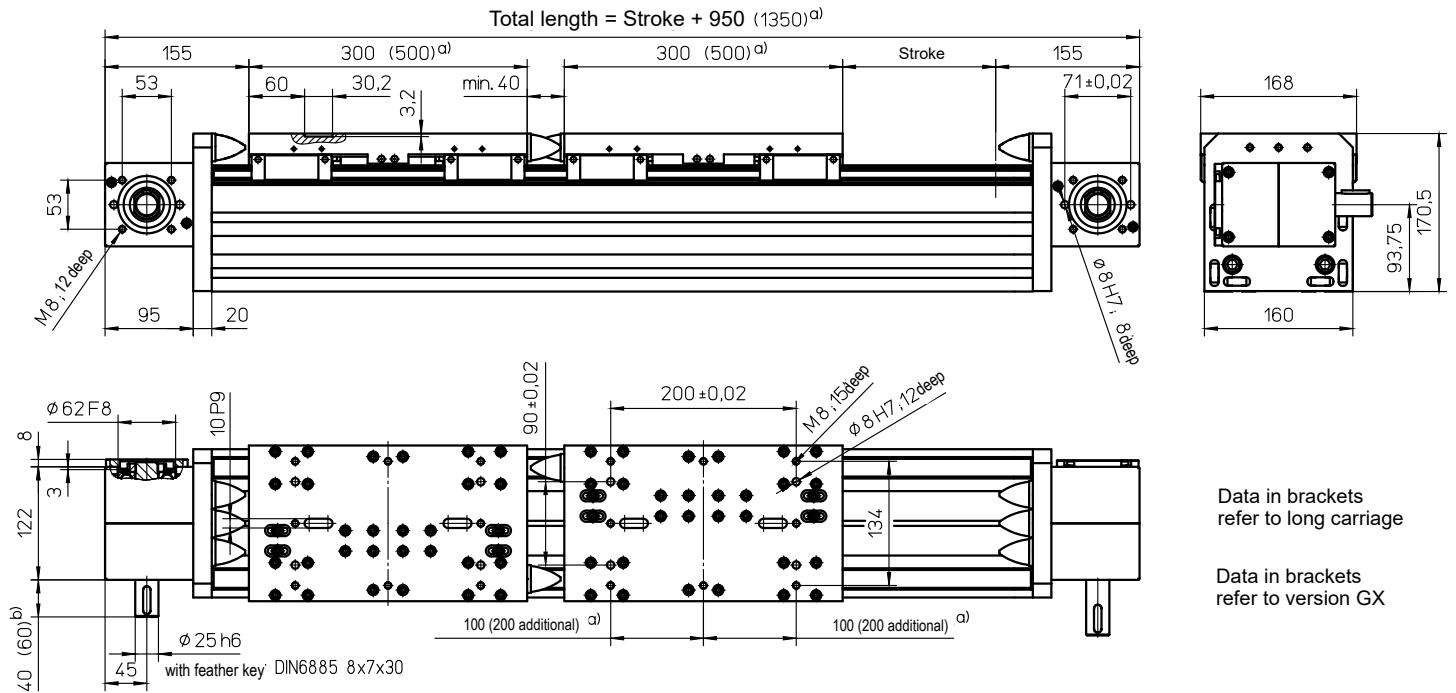

Weights ZSSD

Basic length without stroke:	39.80 kg
100 mm stroke:	2.50 kg
Entire carriage 300 mm:	7.00 kg
Entire carriage 500 mm:	9.20 kg
Max. total length: (longer on request)	8200 mm

Technical Data ZSSD

Max. speed:	5.00 m/s
Max. acceleration:	60 m/s ²
Repeat accuracy:	± 0.08 mm
Idle torque:	4,00 Nm
Moment of inertia:	8.75 · 10 ⁻³ kgm ²
Drive element:	2 x Toothed belt 32 AT10
Stroke per revolution:	210 mm

Forces and moments

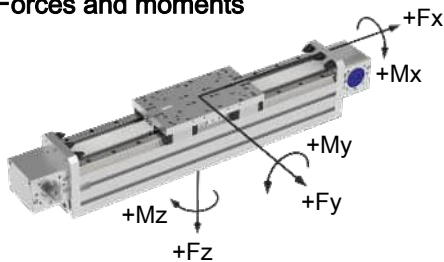

ZSSD	
Forces	Dynamic [N]
F_x^{c)}	2200
F_y	10000
F_z	16000
Moments	Dynamic [Nm]
M_x	1800
M_y	5000 (8000)
M_z	4000 (7000)

^{c)} Maximum value (see diagram „F_x-v-Diagram“)
Data in brackets refer to long carriage (500)

F_x - v - Diagram

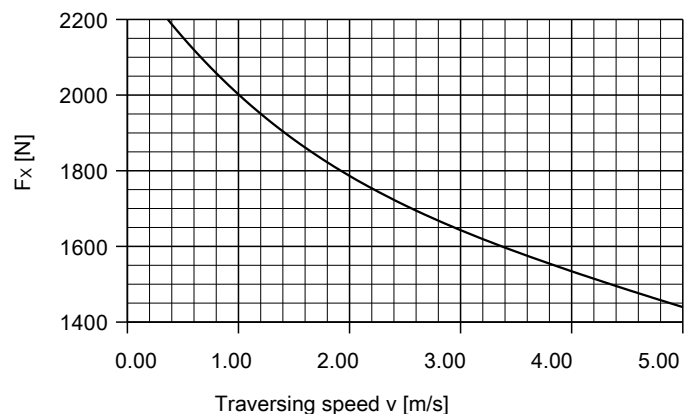

These data apply to each carriage.

with rack-and-pinion drive (helical) and double linear guide (AZSS)

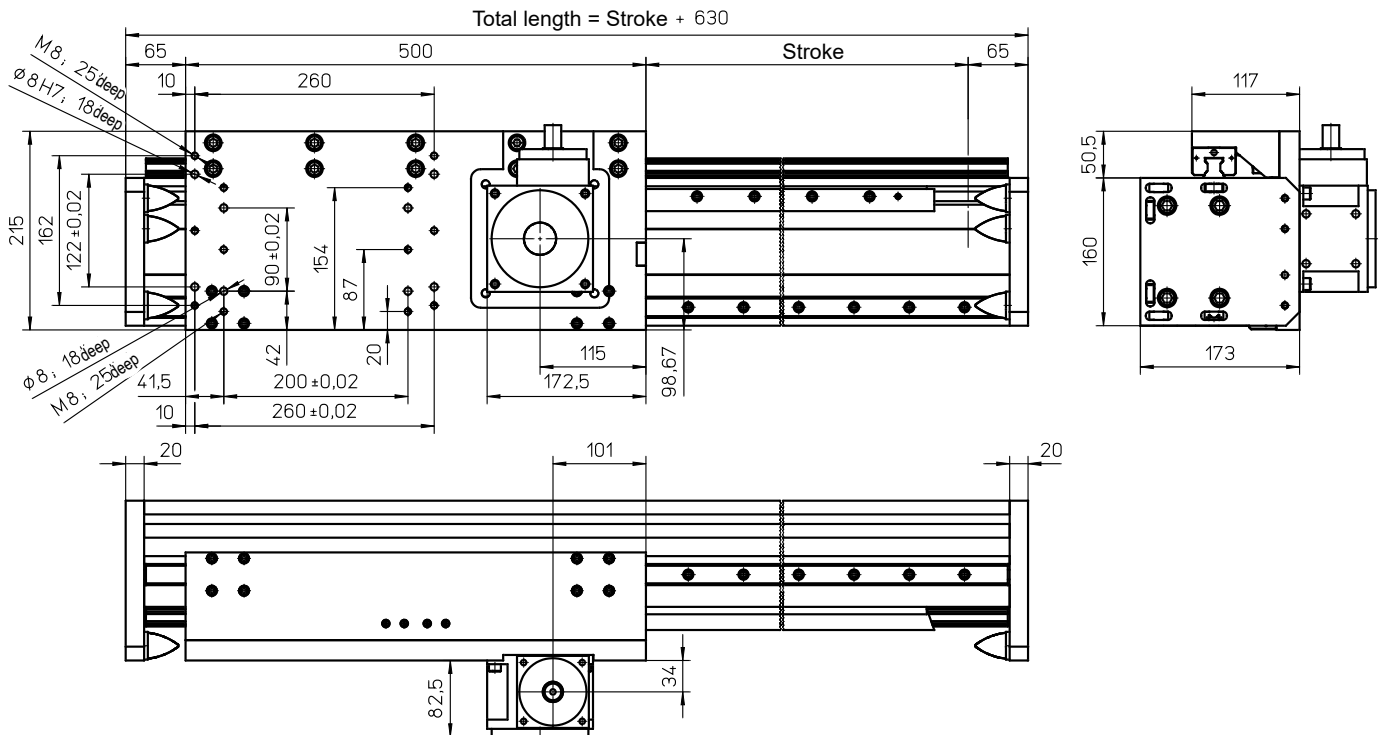

Weights

	AZSS
Basic length without stroke:	33.25 kg*
100 mm stroke:	3.00 kg
Carriage 500 mm:	13.90 kg
Gears D75 / D90:	6.30 / 10.50 kg
Max. total length: (longer on request)	8000 mm

Forces and moments

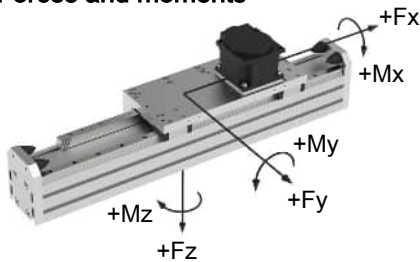

	AZSS-D75	AZSS-D90
Forces	Dynamic [N]	
F_x	1500-2200 **	3000-4000 **
F_y	12000	
F_z	12000	
Moments	Dynamic [Nm]	
M_x	2500	
M_y	7000	
M_z	7000	

Technical Data

	AZSS
Max. speed:	5.00 m/s (D75) / 4.50 m/s (D90)
Max. acceleration:	20 m/s ²
Repeat accuracy:	± 0.05 mm
Idle torque at drive pinion:	5.80 Nm
Rack and pinion:	Module 2 helical
Drive pinion:	Module 2, 30 teeth
Stroke per revolution:	200 mm
Servo-high-performance-gear:	DynaGear D75 / D 90
Ratios:	5 / 10 / 15

	D75	D90
Load F_x	Dynamic [N]	
$i = 5:1$	2200	4000
$i = 10:1$		
$i = 15:1$	1500	3000

Preferred gear: D75
Efficiency of gears: > 96 %

Variants for gear mounting see page G29.

* inclusive standard gear

** depending on gear ratio (see table to right)

with rack-and-pinion drive (helical) and double linear guide (AZSH)

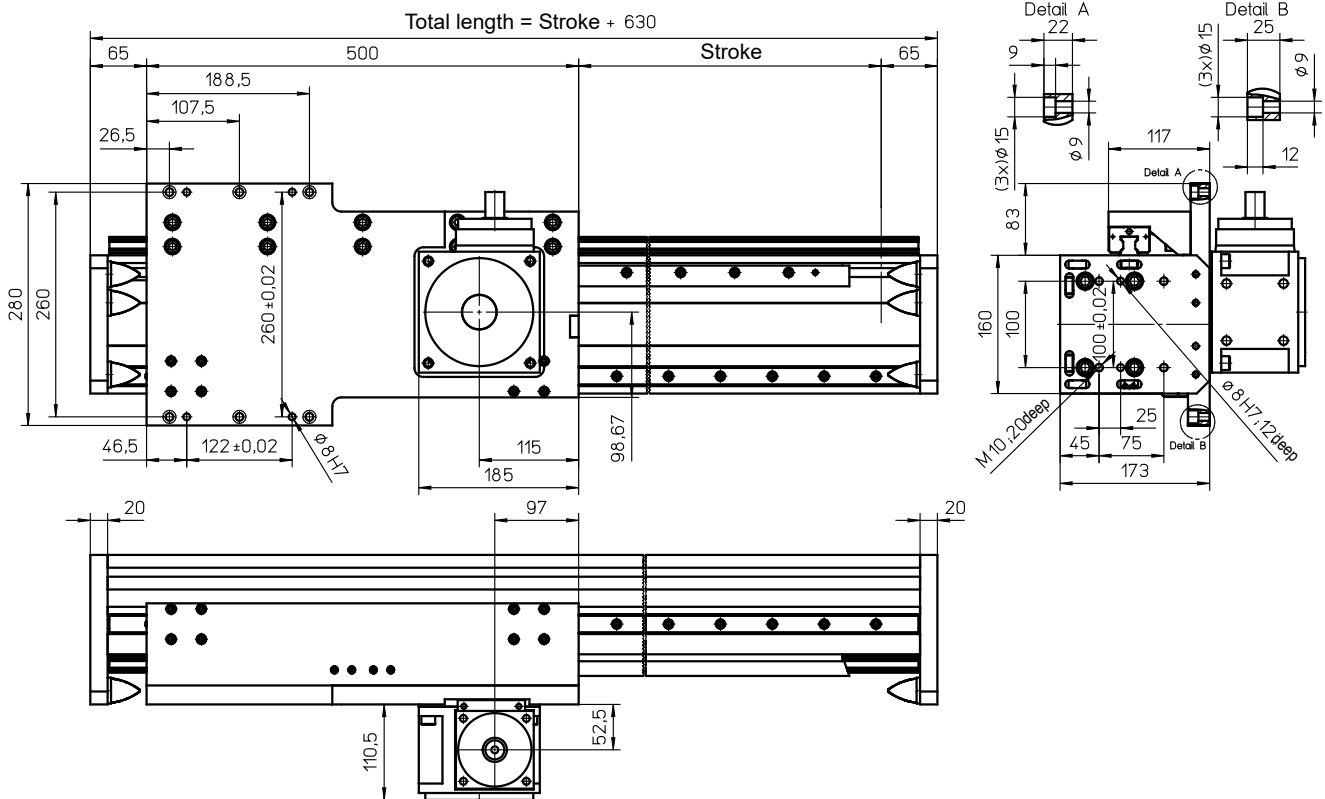

Weights

	AZSH
Basic length without stroke:	34.05 kg*
100 mm stroke:	3.00 kg
Carriage 500 mm:	14.70 kg
Gears D75 / D90:	6.30 / 10.50 kg
Max. total length: (longer on request)	8000 mm

Forces and moments

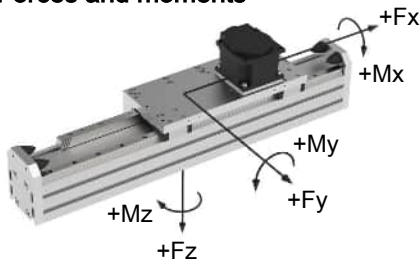

	AZSH-D75	AZSH-D90
Forces	Dynamic [N]	
F_x	1500-2200 **	3000-4000 **
F_y	12000	
F_z	12000	
Moments	Dynamic [Nm]	
M_x	2500	
M_y	7000	
M_z	7000	

Technical Data

	AZSH
Max. speed:	5.00 m/s (D75) / 4.50 m/s (D90)
Max. acceleration:	20 m/s ²
Repeat accuracy:	± 0.05 mm
Idle torque at drive pinion:	5.80 Nm
Rack and pinion:	Module 2 helical
Drive pinion:	Module 2, 30 teeth
Stroke per revolution:	200 mm
Servo-high-performance-gear:	DynaGear D75 / D 90
Ratios:	5 / 10 / 15

	D75	D90
Load F_x	Dynamic [N]	
$i = 5:1$	2200	4000
$i = 10:1$		
$i = 15:1$	1500	3000

Preferred gear: D90
Efficiency of gears: > 96 %

Variants for gear mounting see page G29.

* inclusive standard gear

** depending on gear ratio (see table to right)

with toothed belt drive and double linear guide (ZSS)

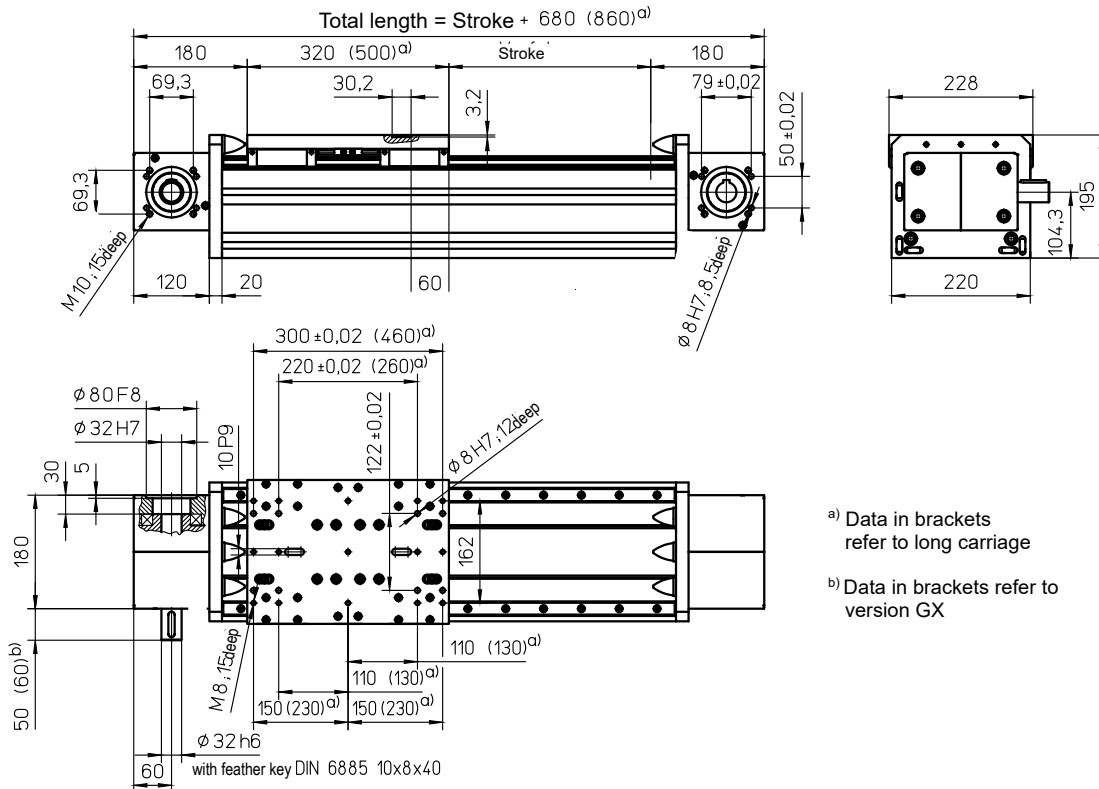

ᵃ) Data in brackets refer to long carriage
ᵇ) Data in brackets refer to version GX

Weights ZSS

Basic length without stroke:	47.00 kg
100 mm stroke:	4.12 kg
Entire carriage 320 mm:	10.50 kg
Entire carriage 500 mm:	13.20 kg
Max. total length: (longer on request)	8260 mm

Technical Data ZSS

Max. speed:	5.00 m/s
Max. acceleration:	60 m/s ²
Repeat accuracy:	± 0.08 mm
Idle torque:	7.00 Nm
Moment of inertia:	3.30 · 10 ⁻² kgm ²
Drive element:	Toothed belt 75 ATL10
Stroke per revolution:	320 mm

Forces and moments

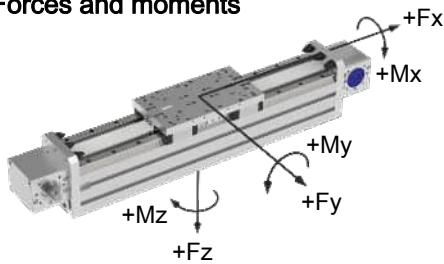

ZSS	
Forces	Dynamic [N]
F_x ^{c)}	6000
F_y	12000
F_z	20000
Moments	Dynamic [Nm]
M_x	2500
M_y	8000 (12000)
M_z	6500 (10000)

^{c)} Maximum value (see diagram "F_x-v-Diagram")
Data in brackets refer to long carriage (500)

F_x - v - Diagram

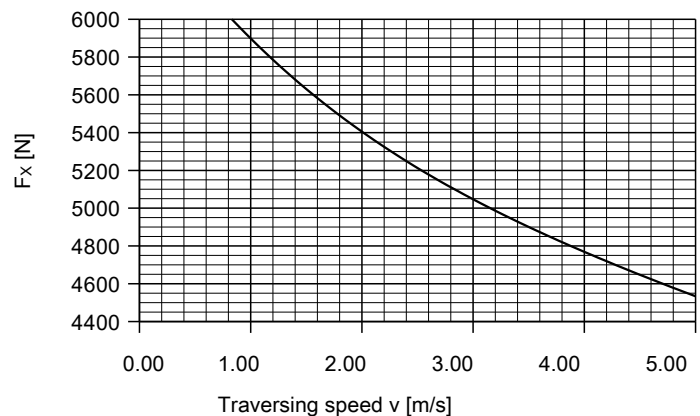

with toothed belt drive and double linear guide and a second independently travelling carriage (ZSSD)

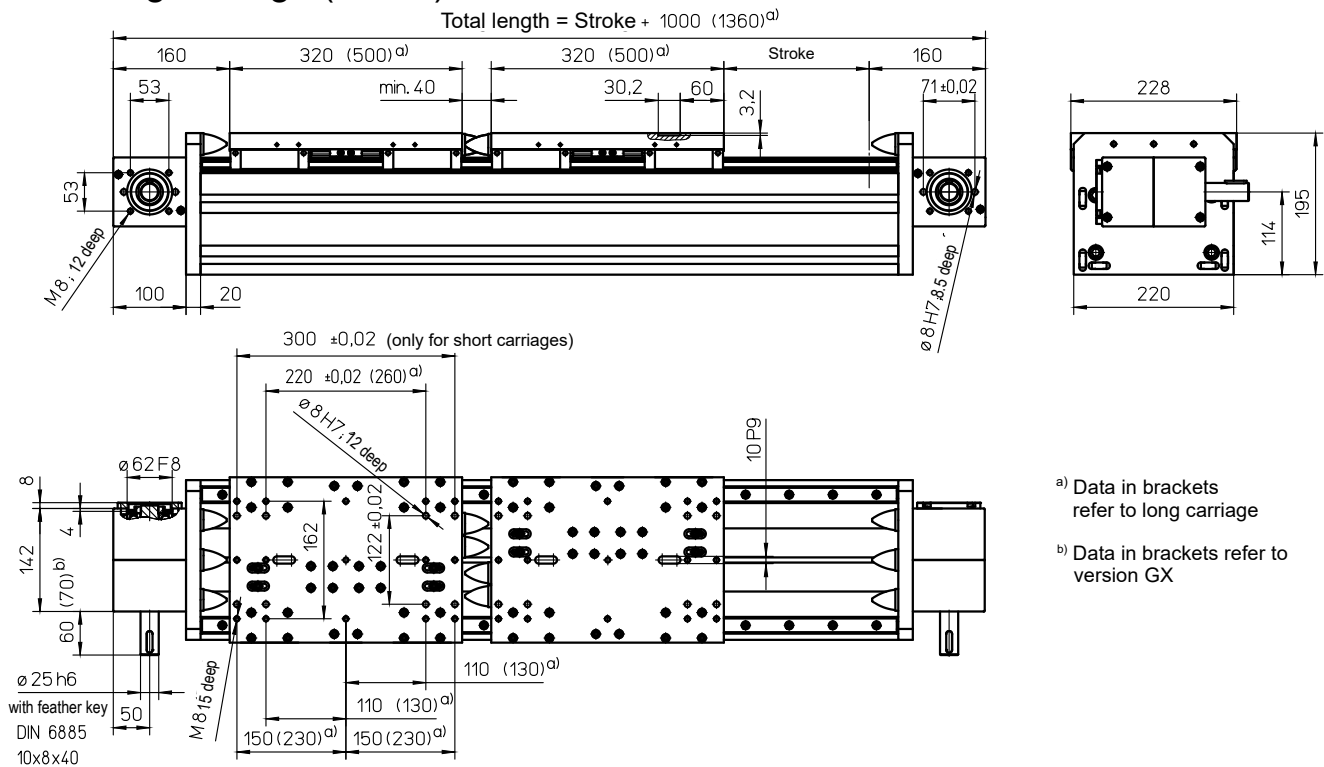

a) Data in brackets refer to long carriage
b) Data in brackets refer to version GX

Weights

	ZSSD
Basic length without stroke	61.30 kg
100 mm stroke:	4.10 kg
Entire carriage 320 mm:	9.30 kg
Entire carriage 500 mm:	11.90 kg
Max. total length: (longer on request)	8220 mm

Technical Data

	ZSSD
Max. speed:	5.00 m/s
Max. acceleration:	60 m/s ²
Repeat accuracy:	± 0,08 mm
Idle torque:	5.25 Nm
Moment of inertia:	1,55 · 10 ⁻² kgm ²
Drive element:	2 x Zahnriemen 40 AT10
Stroke per revolution:	240 mm

Forces and moments

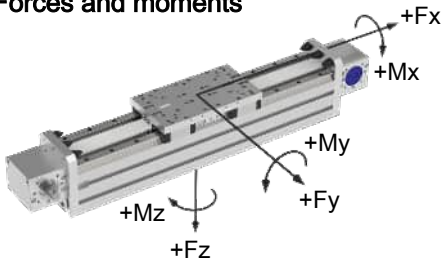

ZSSD	
Forces	Dynamic [N]
F _x ^{c)}	2800
F _y	12000
F _z	20000
Moments	Dynamic [Nm]
M _x	2500
M _y	8000 (12000)
M _z	6500 (10000)

^{c)} Maximum value (see diagram "F_x-v-Diagram")
Data in brackets refer to long carriage (500)

F_x - v - Diagram

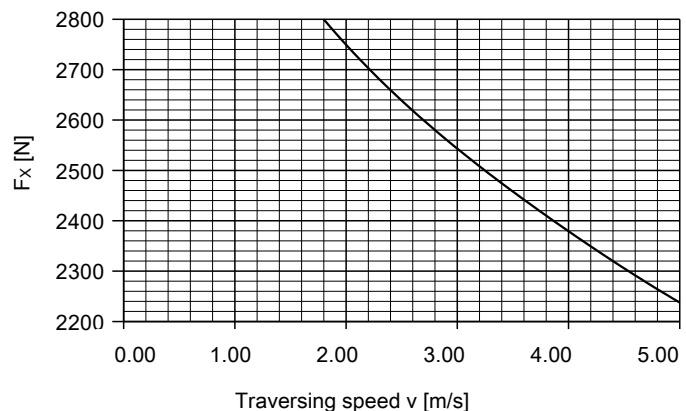

These data apply to each carriage.

with toothed belt drive and double linear guide (ASS)

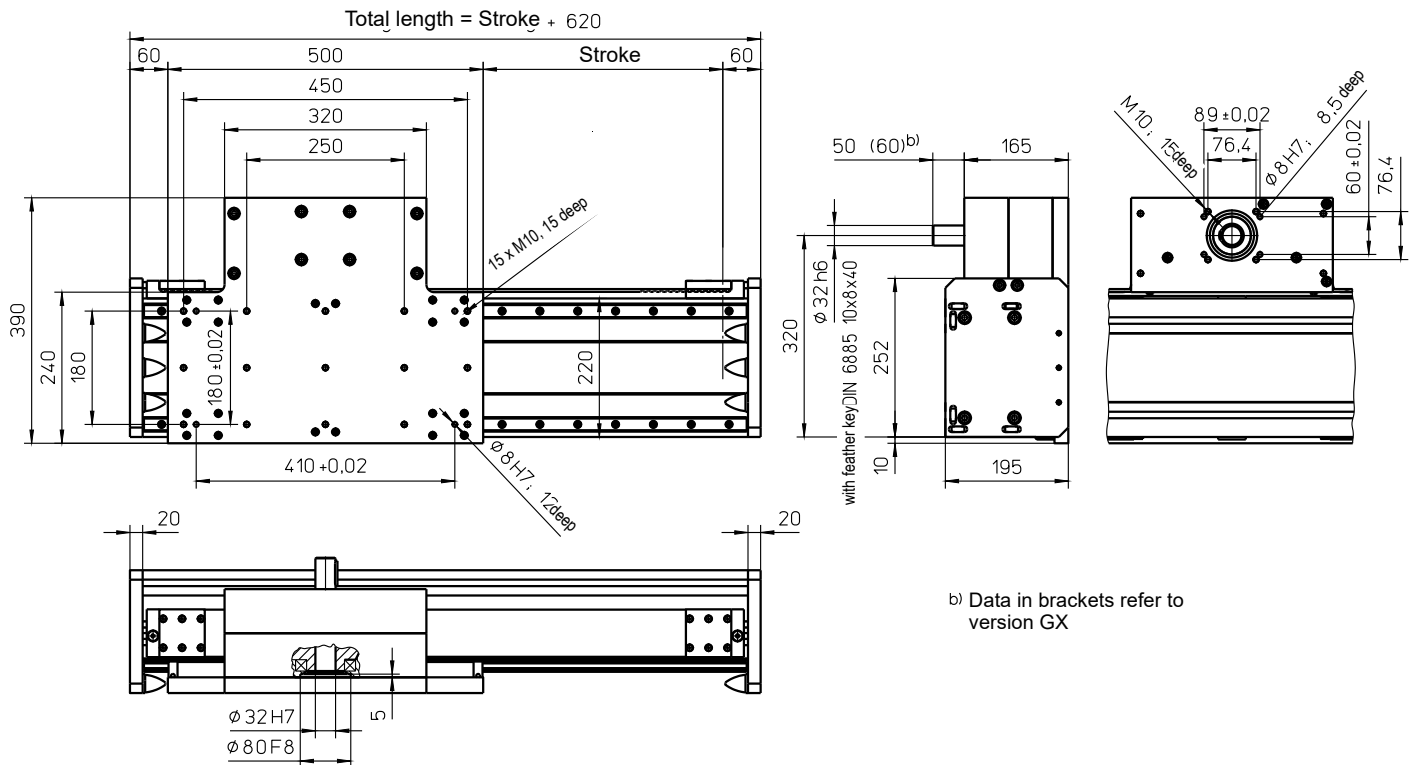

b) Data in brackets refer to version GX

Weights	ASS
Basic length without stroke:	63.90 kg
100 mm stroke:	4.10 kg
Entire carriage 500 mm:	31.70 kg

Max. total length: 8020 mm
(longer on request)

Technical Data	ASS
Max. speed:	5.00 m/s
Max. acceleration:	60 m/s ²
Repeat accuracy:	± 0.08 mm
Idle torque:	8.83 Nm
Moment of inertia: *	3.75 · 10 ⁻² kgm ²
Drive element:	Toothed belt 75 AT10-E
Stroke per revolution:	320 mm

Forces and moments

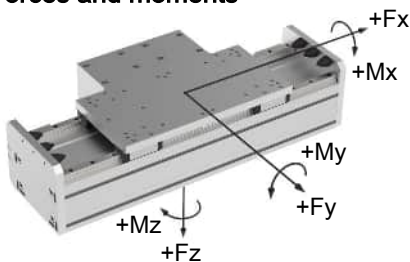

* (entire carriage traverses)

ASS	
Forces	Dynamic [N]
F_x^{c)}	6000
F_y	12000
F_z	20000
Moments	Dynamic [Nm]
M_x	2500
M_y	12000
M_z	10000

c) Maximum value (see diagram "F_x-v-Diagram")

F_x - v - Diagram

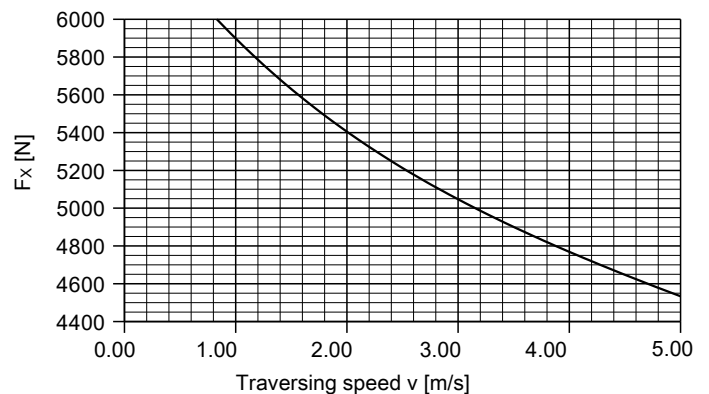

Note:

Only insert linear drive with drive housing facing upwards if you have a horizontal installation position.

with rack-and-pinion drive module 2 (helical)
and double linear guide (AZSS)

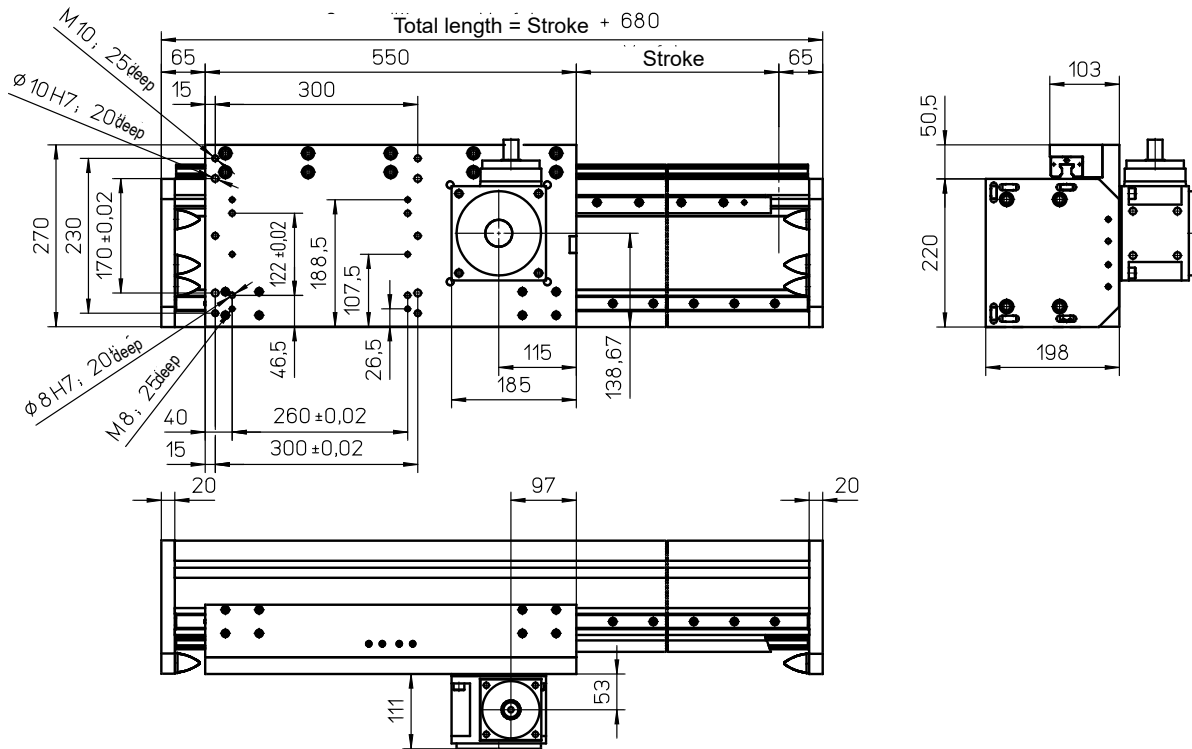

Weights

	AZSS
Basic length without stroke:	49.80 kg*
100 mm stroke:	4.60 kg
Carriage 550 mm:	18.10 kg
Gears D90 / D115:	10.35 / 16.70 kg
Max. total length: (longer on request)	8020 mm

Forces and moments

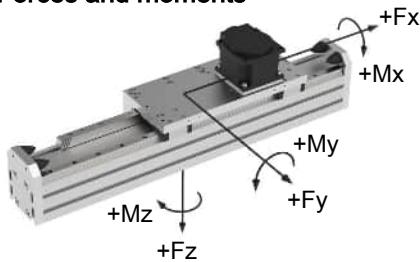

	AZSS-D90	AZSS-D115
Forces	Dynamic [N]	
F_x	3000-4000 **	5000-6000 **
F_y	20000	
F_z	20000	
Moments	Dynamic [Nm]	
M_x	4000	
M_y	8000	
M_z	8000	

Technical Data

	AZSS
Max. speed:	4.50 m/s (D90) / 4.00 m/s (D115)
Max. acceleration:	20 m/s ²
Repeat accuracy:	± 0.05 mm
Idle torque at drive pinion:	7.2 Nm
Rack and pinion:	Module 2 helical
Drive pinion:	Module 2, 30 teeth
Stroke per revolution:	200 mm
Servo-high-performance-gear:	DynaGear D90 / D115
Ratios:	5 / 10 / 15

	D90	D115
Load F_x	Dynamic [N]	
i = 5:1	4000	6000
i = 10:1		
i = 15:1	3000	5000

Preferred gear: D90
Efficiency of gears: > 96 %

Variants for gear mounting see page G29.

* inclusive standard gear

** depending on gear ratio (see table to right)

with rack-and-pinion drive module 3 (helical)
and double linear guide (AZSS)

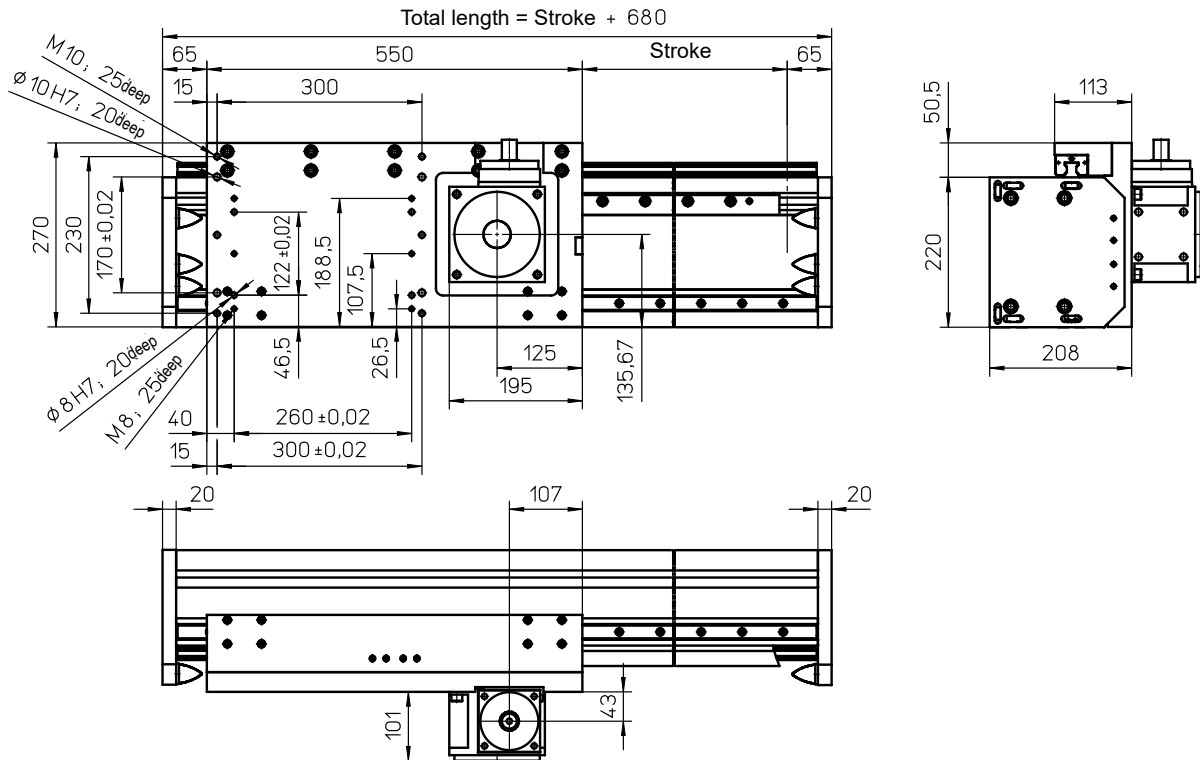

Weights

	AZSS
Basic length without stroke:	52.70 kg*
100 mm stroke:	4.80 kg
Carriage 550 mm:	20.40 kg
Gears D90 / D115:	10.35 / 16.65 kg
Max. total length: (longer on request)	8020 mm

Forces and moments

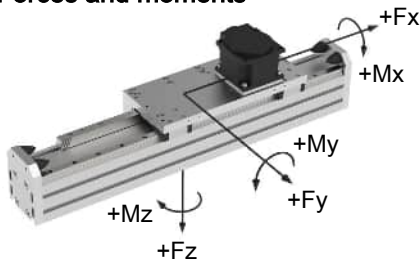

	AZSS-D90	AZSS-D115
Forces	Dynamic [N]	
F_x	3000-4000 **	5000-7500 **
F_y	20000	
F_z	20000	
Moments	Dynamic [Nm]	
M_x	4000	
M_y	8000	
M_z	8000	

Technical Data

	AZSS
Max. speed:	4.50 m/s (D90) / 4.00 m/s (D115)
Max. acceleration:	20 m/s ²
Repeat accuracy:	± 0.05 mm
Idle torque at drive pinion:	7.20 Nm
Rack and pinion:	Module 3 helical
Drive pinion:	Module 3, 20 teeth
Stroke per revolution:	200 mm
Servo-high-performance-gear:	DynaGear D90 / D115
Ratios:	5 / 10 / 15

	D90	D115
Load F_x	Dynamic [N]	
i = 5:1	4000	7500
i = 10:1		
i = 15:1	3000	5000

Preferred gear: D90
Efficiency of gears: > 96 %

Variants for gear mounting see page G29.

* inclusive standard gear

** depending on gear ratio (see table to right)

with rack-and-pinion drive module 2 (helical)
and double linear guide (AZSH)

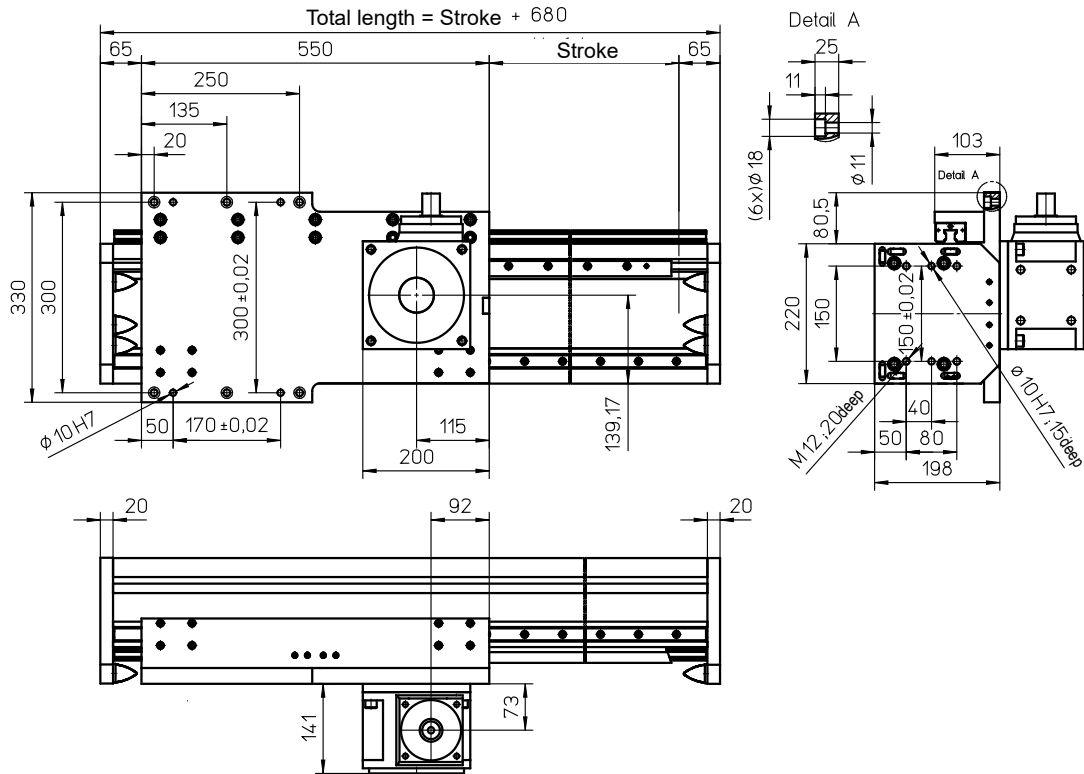

Weights

	AZSH
Basic length without stroke:	50.80 kg*
100 mm stroke:	4.60 kg
Carriage 550 mm:	19.10 kg
Gears D90 / D115:	10.35 / 16.70 kg

Max. total length: 8020 mm
(longer on request)

Forces and moments

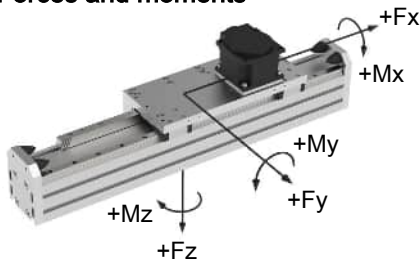

	AZSH-D90	AZSH-D115
Forces	Dynamic [N]	
F_x	3000-4000 **	5000-6000 **
F_y	20000	
F_z	20000	
Moments	Dynamic [Nm]	
M_x	4000	
M_y	8000	
M_z	8000	

Technical Data

	AZSH
Max. speed:	4.50 m/s (D90) / 4.00 m/s (D115)
Max. acceleration:	20 m/s ²
Repeat accuracy:	± 0.05 mm
Idle torque at drive pinion:	7.20 Nm
Rack and pinion:	Module 2 helical
Drive pinion:	Module 2, 30 teeth
Stroke per revolution:	200 mm
Servo-high-performance-gear:	DynaGear D90 / D115
Ratios:	5 / 10 / 15

	D90	D115
Load F_x	Dynamic [N]	
$i = 5:1$	4000	6000
$i = 10:1$		
$i = 15:1$	3000	5000

Preferred gear: D115
Efficiency of gears: > 96 %

Variants for gear mounting see page G29.

* inclusive standard gear

** depending on gear ratio (see table to right)

with rack-and-pinion drive module 3 (helical)
and double linear guide (AZSH)

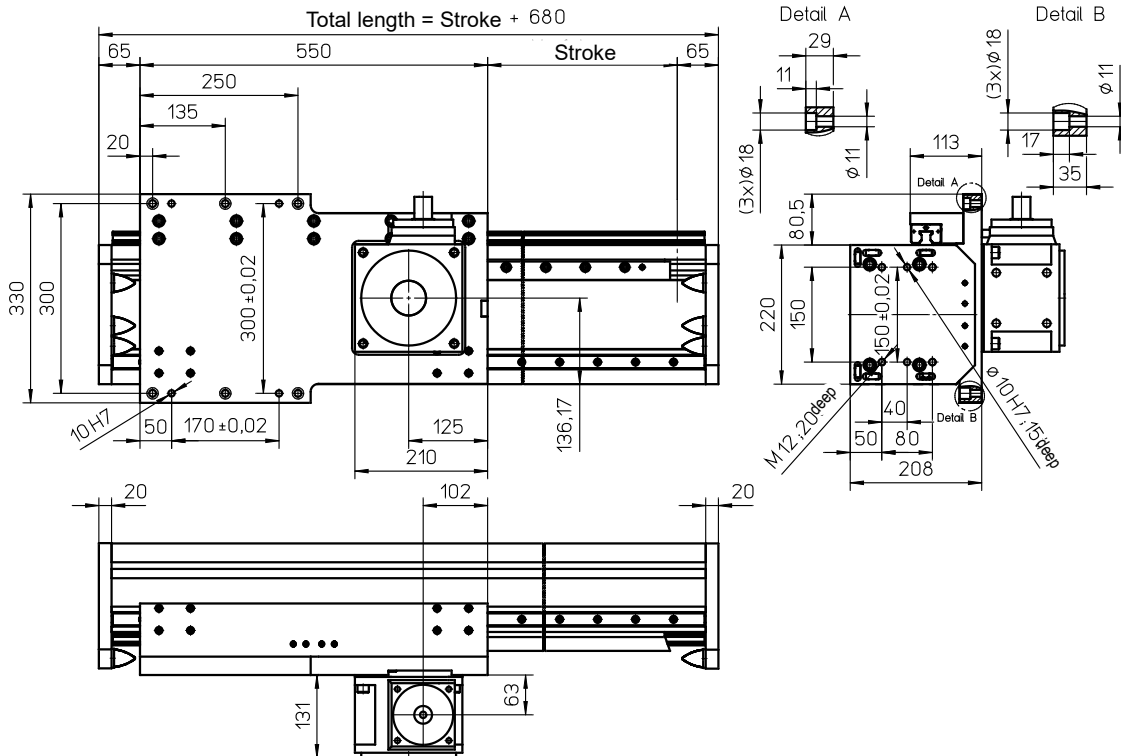

Weights

	AZSH
Basic length without stroke:	53.90 kg*
100 mm stroke:	4.80 kg
Carriage 550 mm:	21.60 kg
Gears D90 / D115:	10.35 / 16.65 kg
Max. total length: (longer on request)	8020 mm

Forces and moments

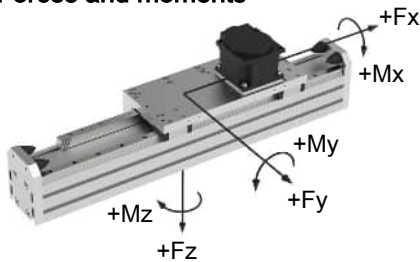

	AZSH-D90	AZSH-D115
Forces	Dynamic [N]	
F_x	3000-4000 **	5000-7500 **
F_y	20000	
F_z	20000	
Moments	Dynamic [Nm]	
M_x	4000	
M_y	8000	
M_z	8000	

Technical Data

	AZSH
Max. speed:	4.50 m/s (D90) / 4.00 m/s (D115)
Max. acceleration:	20 m/s ²
Repeat accuracy:	± 0.05 mm
Idle torque at drive pinion:	7.20 Nm
Rack and pinion:	Module 3 helical
Drive pinion:	Module 3, 20 teeth
Stroke per revolution:	200 mm
Servo-high-performance-gear:	DynaGear D90 / D115
Ratios:	5 / 10 / 15

	D90	D115
Load F_x	Dynamic [N]	
$i = 5:1$	4000	7500
$i = 10:1$		
$i = 15:1$	3000	5000

Preferred gear: D115
Efficiency of gears: > 96 %

Variants for gear mounting see page G29.

* inclusive standard gear

** depending on gear ratio (see table to right)

with toothed belt drive and double linear guide (ZSS)

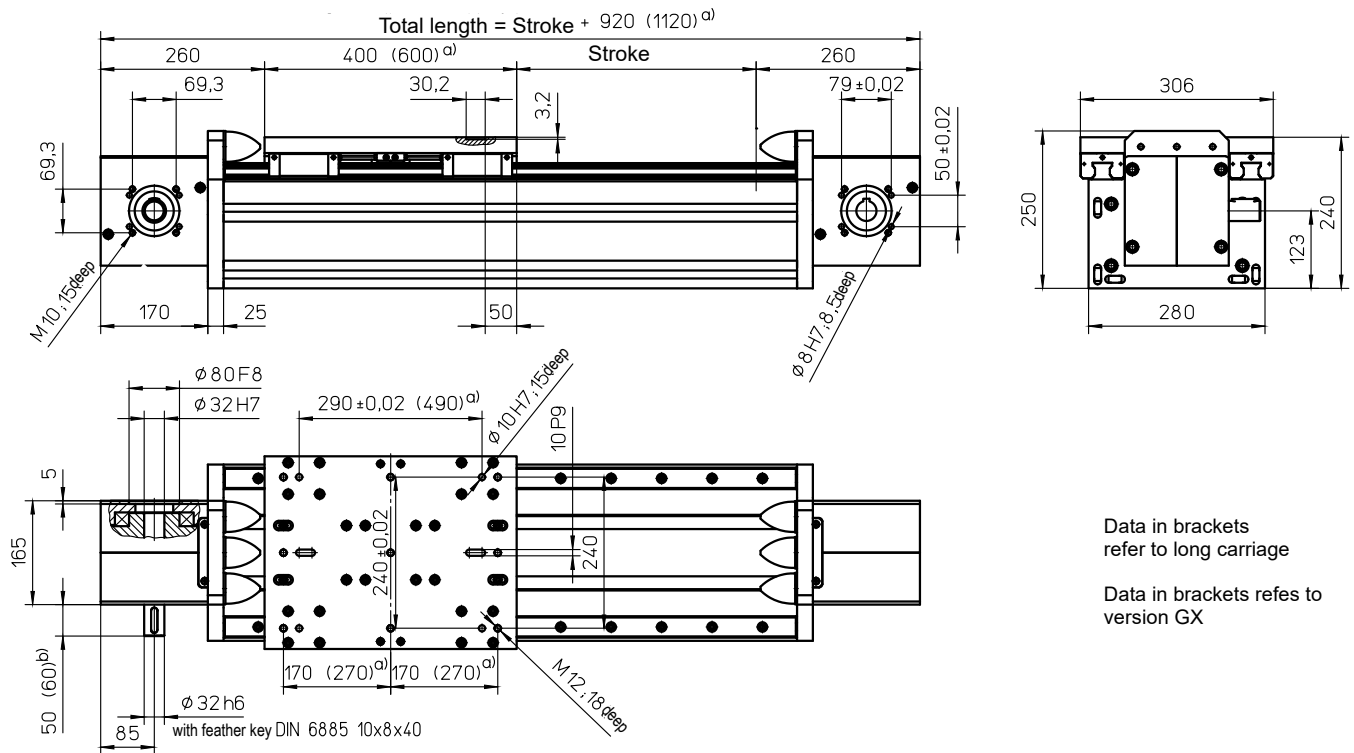

Data in brackets refer to long carriage

Data in brackets refer to version GX

Weights	ZSS
Basic length without stroke:	91.05 kg
100 mm stroke:	6.15 kg
Entire carriage 400 mm:	19.20 kg
Entire carriage 600 mm:	23.80 kg
Max. total length: (longer on request)	8370 mm

Technical Data	ZSS
Max. speed:	5.00 m/s
Max. acceleration:	60 m/s ²
Repeat accuracy:	± 0.08 mm
Idle torque:	11.00 Nm
Moment of inertia:	0.12 kgm ²
Drive element:	Toothed belt 75 ATS15
Stroke per revolution:	450 mm

Forces and moments

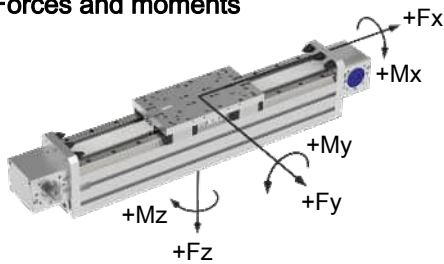

ZSS	
Forces	Dynamic [N]
F_x^{c)}	10000
F_y	20000
F_z	30000
Moments	Dynamic [Nm]
M_x	4000
M_y	15000 (25000)
M_z	12000 (20000)

^{c)} Maximum value (see diagram "F_x-v-Diagram")
Data in brackets refer to long carriage (600)

F_x - v - Diagram

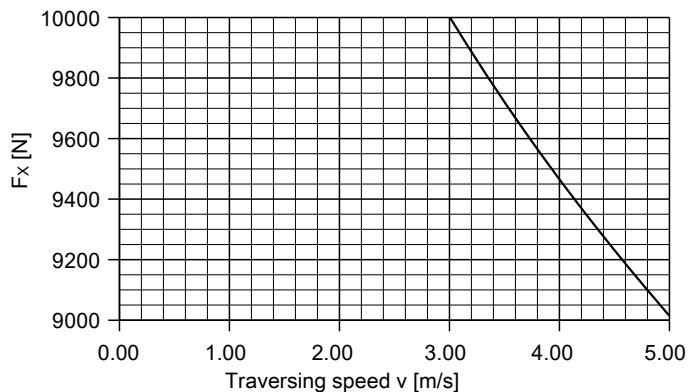

with toothed belt drive and double linear guide and a second independently travelling carriage (ZSSD)

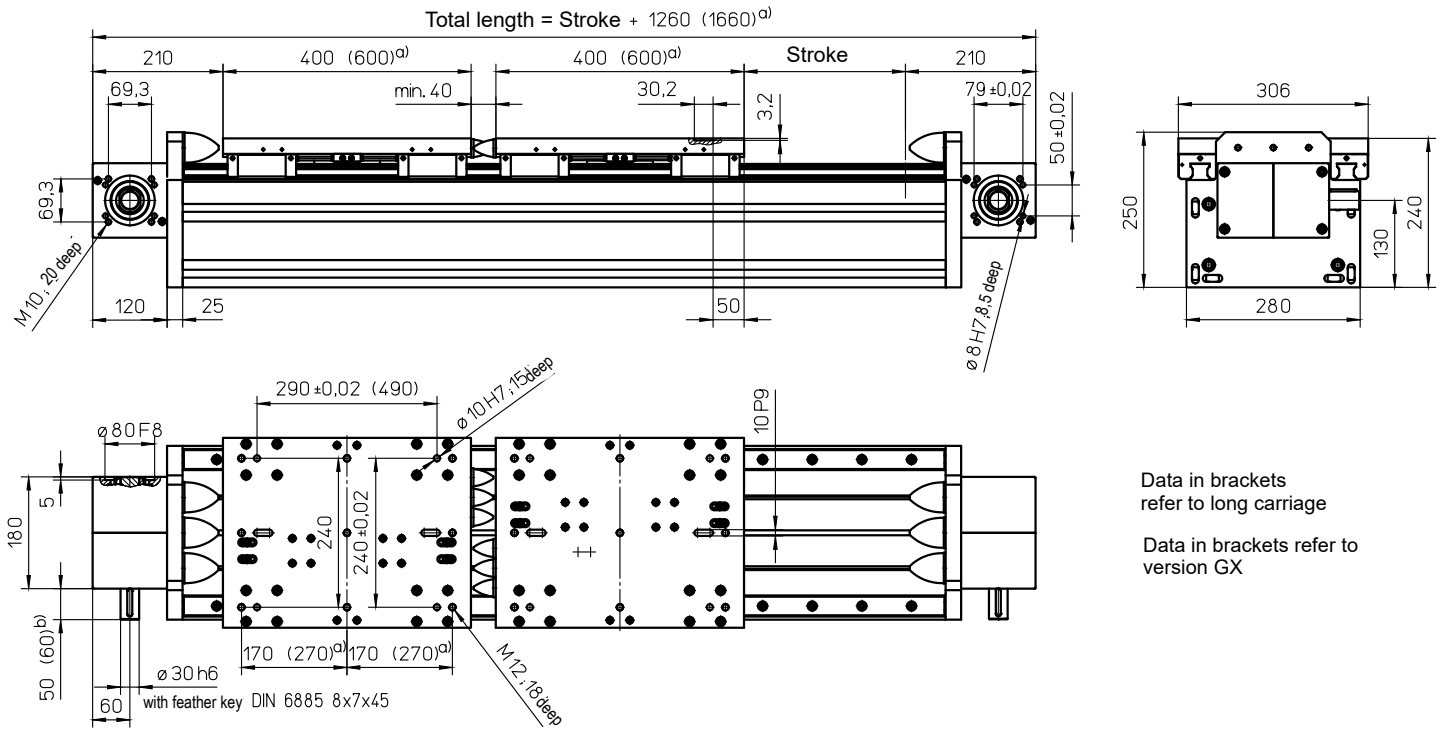

Weights	ZSSD
Basic length without stroke:	142.75 kg
100 mm stroke:	6.30 kg
Entire carriage 400 mm:	18.00 kg
Entire carriage 600 mm:	22.55 kg
Max. total length: (longer on request)	8270 mm

Technical Data	ZSSD
Max. speed:	5.00 m/s
Max. acceleration:	60 m/s ²
Repeat accuracy:	± 0,08 mm
Idle torque:	11.00 Nm
Moment of inertia:	4.50 · 10 ⁻² kgm ²
Drive element:	2 x Zahnriemen 50 ATL 10
Stroke per revolution:	300 mm

Forces and moments

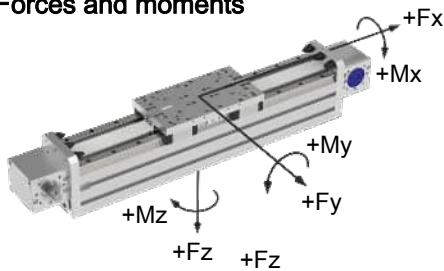

ZSSD	
Forces	Dynamic [N]
F_x^{c)}	4000
F_y	20000
F_z	30000
Moments	Dynamic [Nm]
M_x	4000
M_y	15000 (25000)
M_z	12000 (20000)

^{c)} Maximum value (see diagram "F_x-v-Diagram")
Data in brackets refer to long carriage (600)

F_x - v - Diagram

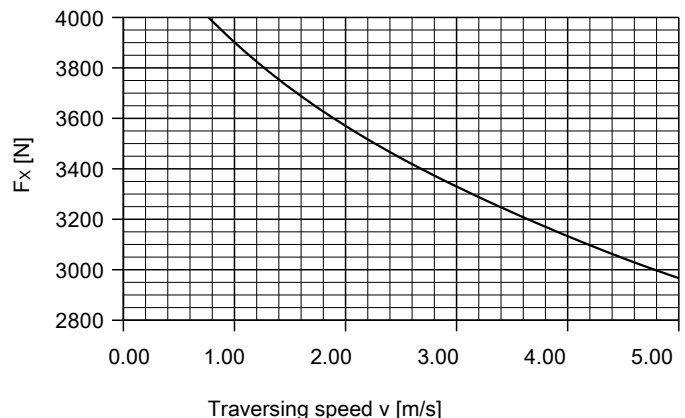

These data apply to each carriage.

with rack-and-pinion drive (helical) and double linear guide (AZSS)

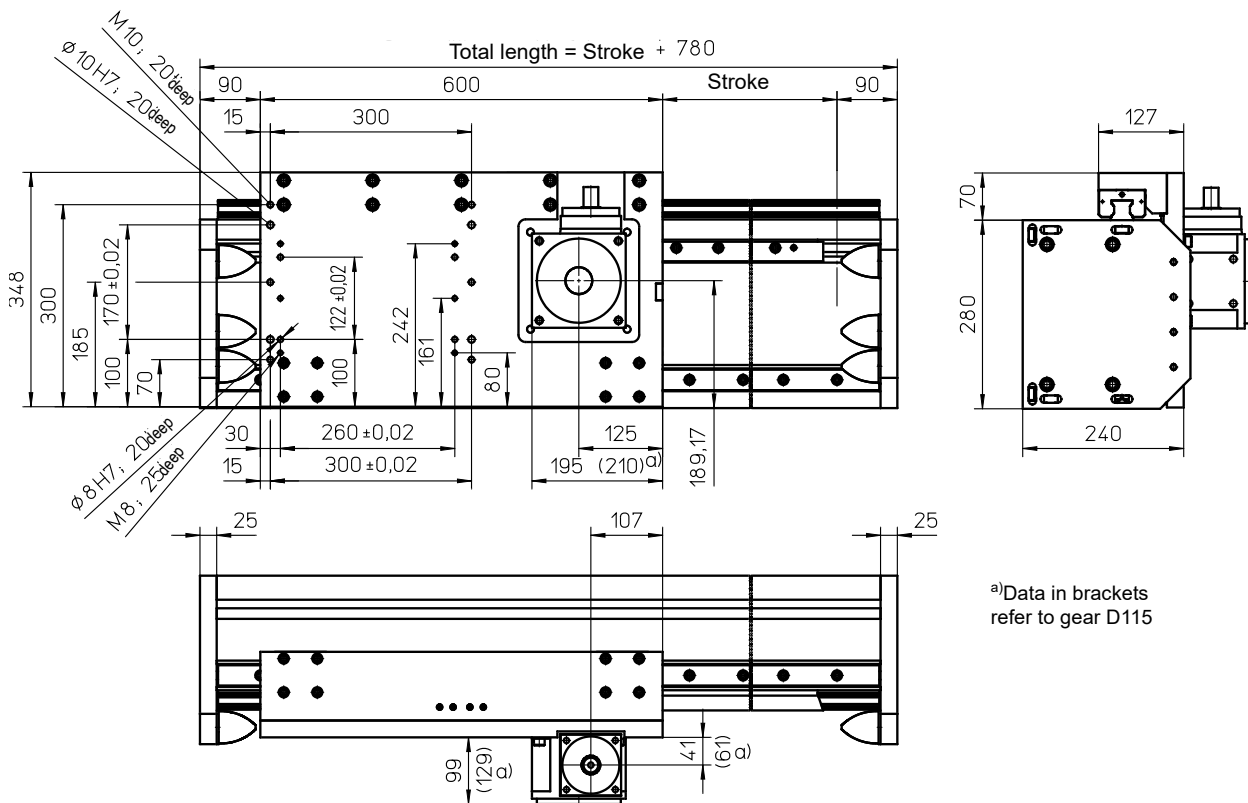

Weights

	AZSS
Basic length without stroke:	84.70 kg*
100 mm stroke:	6.95 kg
Carriage drive 600 mm:	27.80 kg
Gears D90 / D115:	10.35 / 16.65 kg

Max. total length: 8030 mm
(longer on request)

Forces and moments

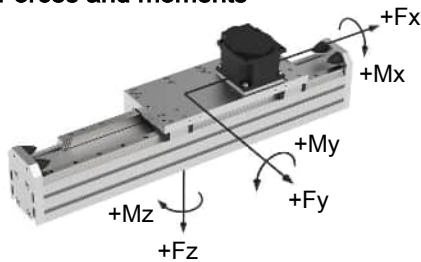

	AZSS-D90	AZSS-D115
Forces	Dynamic [N]	
F_x	3000-4000 **	5000-7500 **
F_y	25000	
F_z	25000	
Moments	Dynamic [Nm]	
M_x	8000	
M_y	16000	
M_z	16000	

Technical Data

	AZSS
Max. speed:	4.50 m/s (D90) / 4.00 m/s (D115)
Max. acceleration:	20 m/s ²
Repeat accuracy:	± 0.05 mm
Idle torque at drive pinion:	8.60 Nm
Rack and pinion:	Module 3 helical
Drive pinion:	Module 3, 20 teeth
Stroke per revolution:	200 mm
Servo-high-performance-gear:	DynaGear D90 / D115
Ratios:	5 / 10 / 15

	D90	D115
Load F_x	Dynamic [N]	
i = 5:1	4000	7500
i = 10:1		
i = 15:1	3000	5000

Preferred gear: D90
Efficiency of gears: > 96 %

Variants for gear mounting see page G29.

* inclusive standard gear

** depending on gear ratio (see table to right)

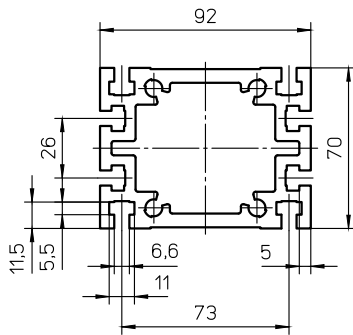

Profile Gamma 90

Specific mass [kg/m]	6.1
Surface measure [mm ²]	2260
Geometrical moment of inertia I _y [mm ⁴]	1373211
Geometrical moment of inertia I _z [mm ⁴]	2297416
Section modulus W _y [mm ³]	39234
Section modulus W _z [mm ³]	49943

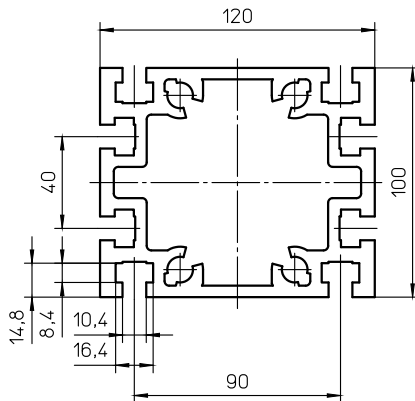

Profile Gamma 120

Specific mass [kg/m]	10.00
Surface measure [mm ²]	3703
Geometrical moment of inertia I _y [mm ⁴]	4632561
Geometrical moment of inertia I _z [mm ⁴]	6689038
Section modulus W _y [mm ³]	95651
Section modulus W _z [mm ³]	111484

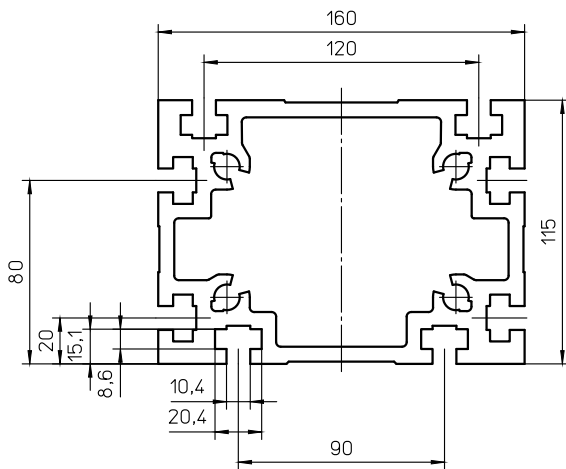

Profile Gamma 160

Specific mass [kg/m]	15.29
Surface measure [mm ²]	5663
Geometrical moment of inertia I _y [mm ⁴]	9540462
Geometrical moment of inertia I _z [mm ⁴]	18690276
Section modulus W _y [mm ³]	163634
Section modulus W _z [mm ³]	233628

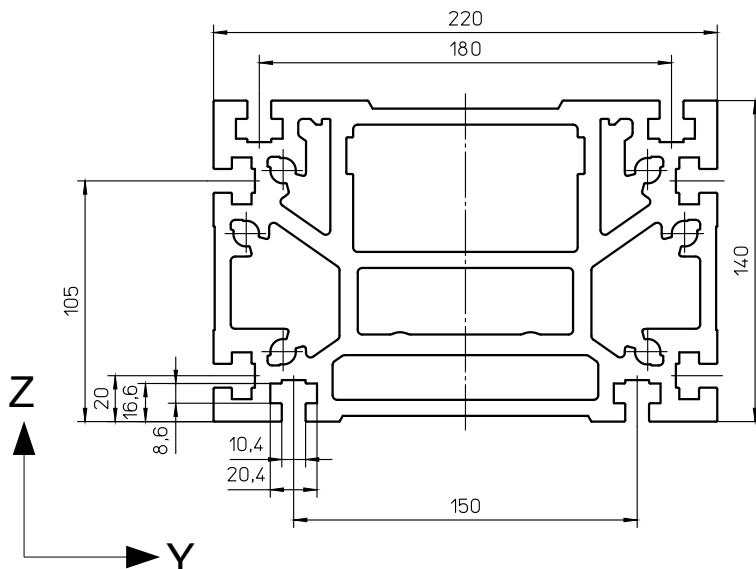

Profile Gamma 220

Specific mass [kg/m]	31.47
Surface measure [mm ²]	11655
Geometrical moment of inertia I _y [mm ⁴]	23604804
Geometrical moment of inertia I _z [mm ⁴]	60771950
Section modulus W _y [mm ³]	333301
Section modulus W _z [mm ³]	552472

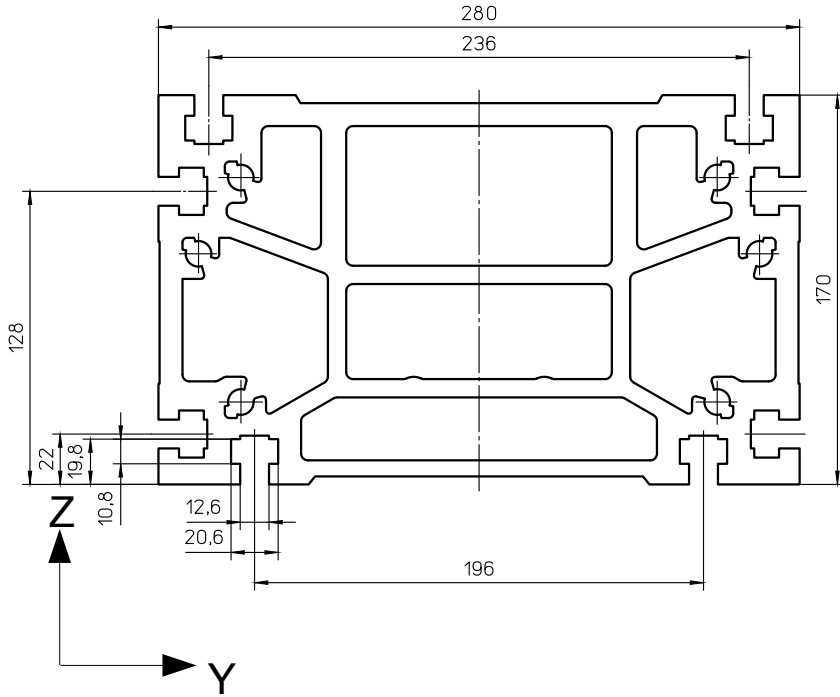

Profile Gamma 280

Specific mass [kg/m]	45.00
Surface measure [mm ²]	16668
Geometrical moment of inertia I _y [mm ⁴]	51584879
Geometrical moment of inertia I _z [mm ⁴]	145637924
Section modulus W _y [mm ³]	593375
Section modulus W _z [mm ³]	1040245

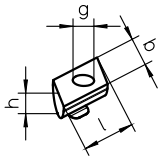
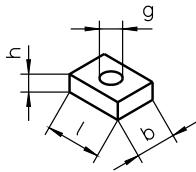

Portal-Linear Drive	NS	ID No.	l [mm]	b [mm]	h [mm]	g
Gamma 90	21	22955	20	10	5	M6
	18	23951	20	16	8	M5
Gamma 120	19	23950	20	16	8	M6
	20	23949	20	16	8	M8
	18	23951	20	16	8	M5
Gamma 160	19	23950	20	16	8	M6
	15	19211	25	18	8	M8
	6	10561	25	18	8	M10
	24	16772	25	17	9,5	M10
Gamma 220	18	23951	20	16	8	M5
	19	23950	20	16	8	M6
	15	19211	25	18	8	M8
	6	10561	25	18	8	M10
Gamma 280	24	16772	25	17	9,5	M10
	19	23950	20	16	8	M6
	15	19211	25	18	8	M8
	6	10561	25	18	8	M10
	24	16772	25	17	9,5	M10
	17	19722	30	20	10	M12

Example:

Gamma 160-ZSS-50 ATL10-240-1000-1620-AZ1-8NS6-1

Product

Unit size

Drive

Z = Toothed belt drive

0 = Without drive

A = Powered carriage

Guide system

S = Rail guide

0 = Without guide

Model

S = Standard (Horizontal)

SD = Standard double (Horizontal)

H = Lifting axis (Vertical)

Drive specifications

Width and type of toothed belt

Stroke per revolution

Stroke

Total length

Accessories

AZ1 = Drive shaft short, mounting side **C**

AZ2 = Drive shaft short, mounting side **D**

AZ6 = Drive shaft long, mounting side **C** and **D**

Further arrangements for drive shaft, see **page Z1**

EO2 / EO10 = Inductive limit switch NC with 2 m / 10 m cable fitted

ES2 / ES10 = Inductive limit switch NO with 2 m / 10 m cable fitted

EMS / EMB = Mechanical limit switch (S = Siemens, B = Balluff) fitted

NS = Sliding block 5 .. 17 (see Table on **page G27**)

Special design

0 = Standard

1 = Special (add specification description)

Further accessories (separate position)

MGK = Motor mounting and coupling (according to dimension sheet)

Example: Gamma 160-AZSS-M2-200-1000-1630-2EO2-8NS6-1

Product _____

Unit size _____

Drive _____

AZ = Rack-and-pinion drive

Guide system _____

S = Rail guide

Model _____

S = Standard (Horizontal)

H = Lifting axis (Vertical)

Drive specifications _____

Drive pinion module (M2 / M3)

Stroke per revolution _____

Stroke _____

Total length _____

Accessories _____

EO2 / EO10 = Inductive limit switch NC with 2m / 10m cable fitted

ES2 / ES10 = Inductive limit switch NO with 2m / 10m cable fitted

EMS / EMB = Mechanical limit switch (S = Siemens, B = Balluff) fitted

NS = Sliding block 5 .. 17 (see Table on page G27)

Special design _____

0 = Standard

1 = Special (add specification description)

Additional information

Gear size and ratio (D55 to D115 / i = 5 to i = 15)

Gear mounting (for example XD)

Gear mounting

Carriage „standard“

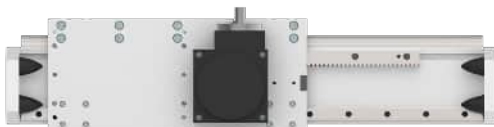

Gear side: B
Gear version (1L): X
With motor mounting side: D

Carriage „mirrored“



Gear side: A
Gear version (3L): L
With motor mounting side: D



Gear side: B
Gear version (1L): X
With motor mounting side: C



Gear side: A
Gear version (3L): L
With motor mounting side: C

Chapter S

Portal Linear Drive

HSB-sigma[®]

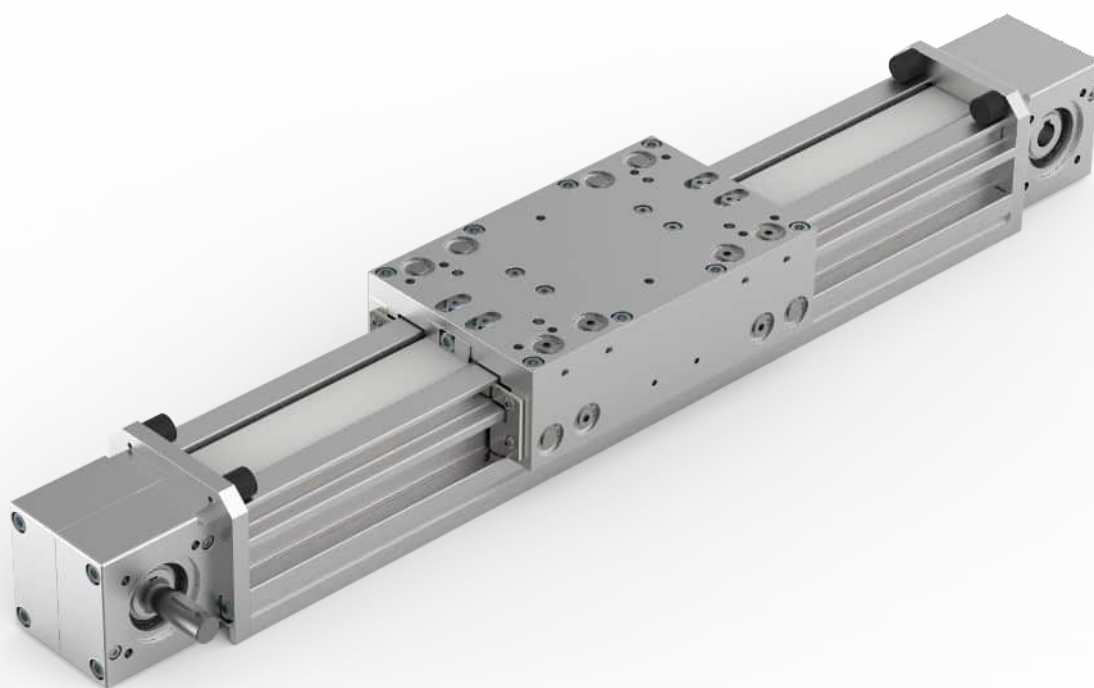

with toothed belt drive and roller guide (ZRS)

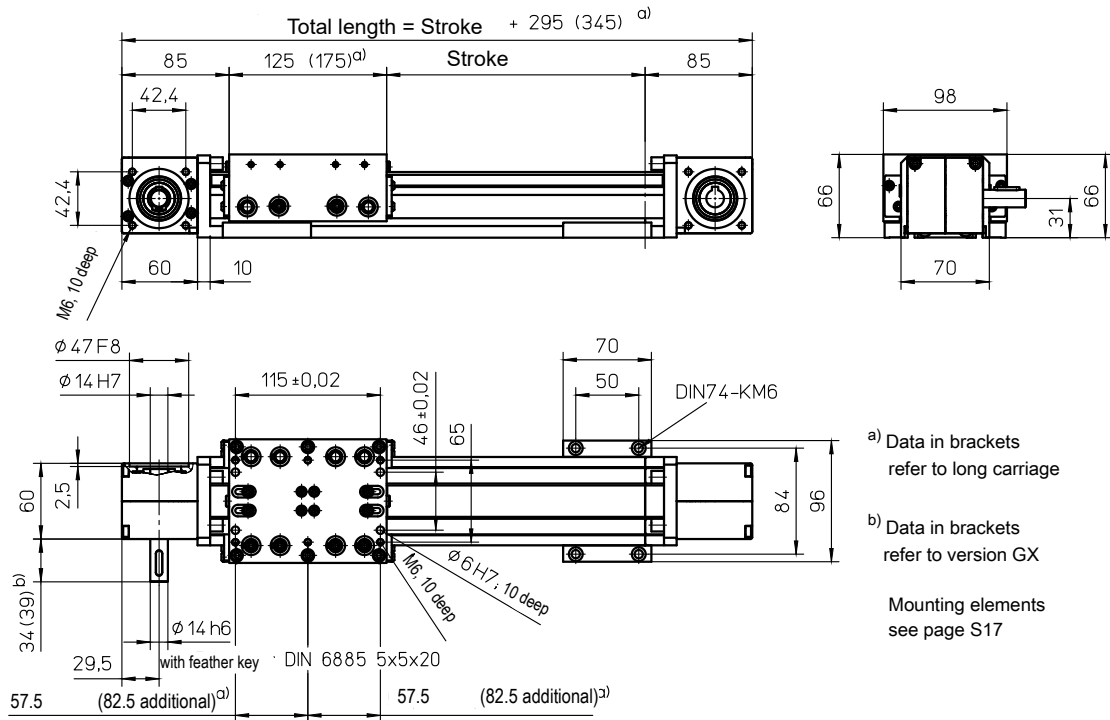

Weights

ZRS

Basic length without stroke:	3.05 kg
100 mm stroke:	0.40 kg
Entire carriage 125 mm:	1.20 kg
Entire carriage 175 mm:	1.35 kg
Max. total length: (longer on request)	8100 mm

Technical Data

ZRS

Max. speed:	6.25 m/s
Max. acceleration:	60 m/s ²
Repeat accuracy:	± 0.08 mm
Idle torque:	0.85 Nm
Moment of inertia:	6.70 · 10 ⁻⁴ kgm ²
Drive element:	Toothed belt 25 AT5-E
Stroke per revolution:	125 mm

Forces and moments

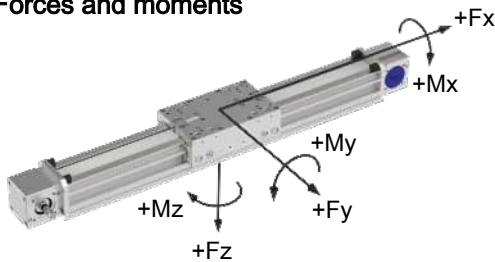

ZRS	
Forces	Dynamic [N]
$F_x^{c)}$	1050
F_y	1350
F_z	1850
$-F_z$	1200
Moments	Dynamic [Nm]
M_x	50
M_y	70 (120)
M_z	80 (110)

F_x - v - Diagram

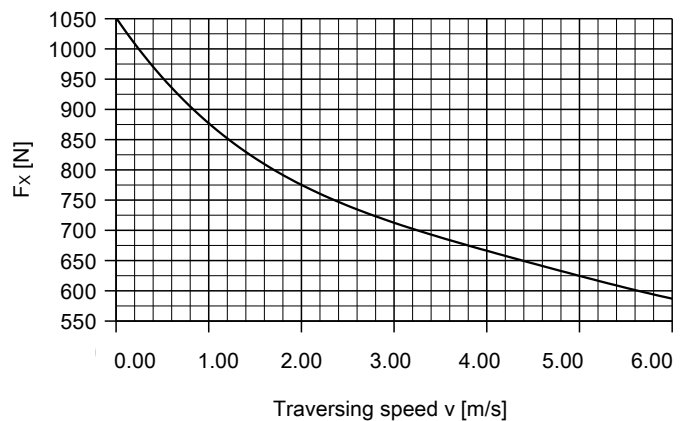

c) Maximum value (see diagram „ F_x -v-Diagram“)
Data in brackets refer to long carriage (175)

with toothed belt drive and roller guide (ARH)

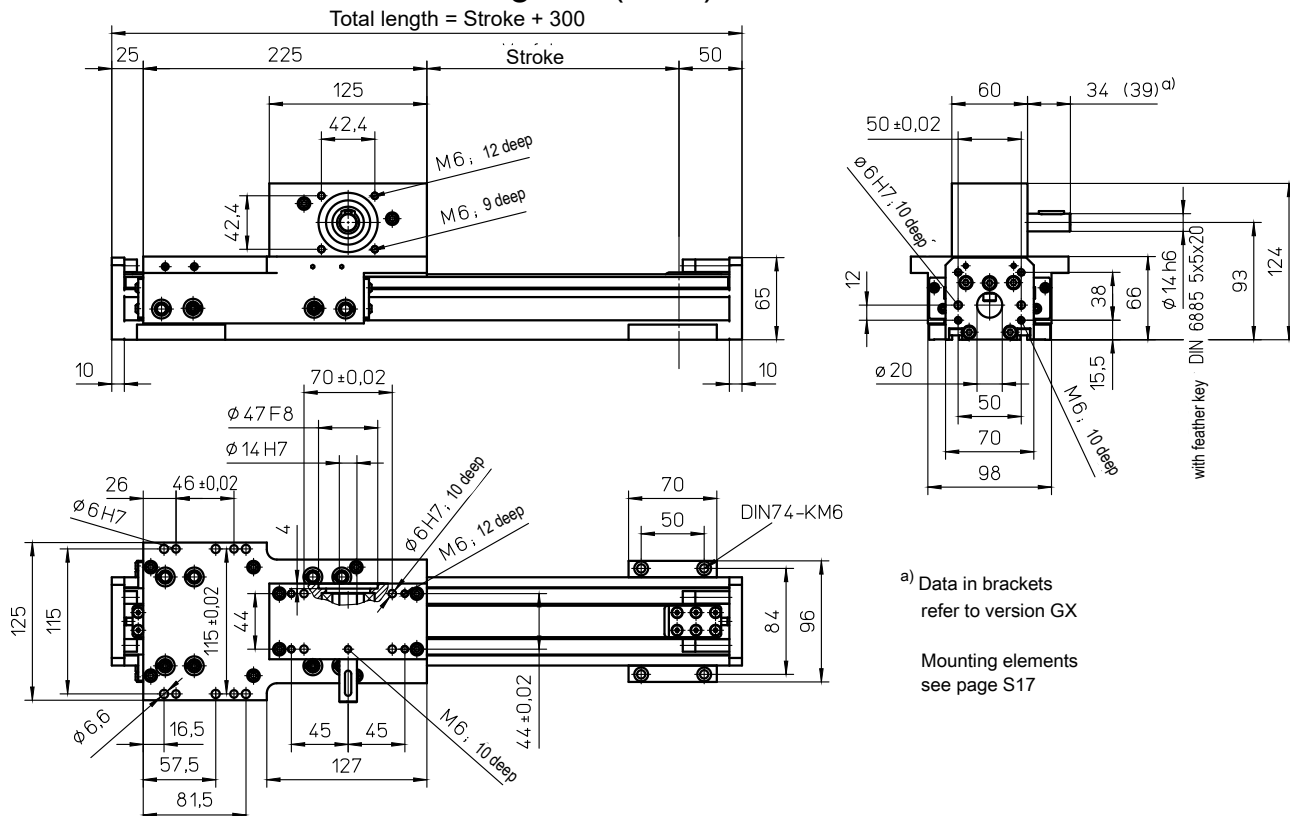

a) Data in brackets refer to version GX

Mounting elements see page S17

Weights

ARH

Basic length without stroke:	4.25 kg
100 mm stroke:	0.40 kg
Entire carriage 225 mm:	2.75 kg
Max. total length: (longer on request)	8000 mm

Technical Data

ARH

Max. speed:	6.25 m/s
Max. acceleration:	60 m/s ²
Repeat accuracy:	± 0.08 mm
Idle torque:	0.85 Nm
Moment of inertia: (rotatory)	5.37 · 10 ⁻⁵ kgm ²
Drive element:	Toothed belt 25 AT5-E
Stroke per revolution:	125 mm

Forces and moments

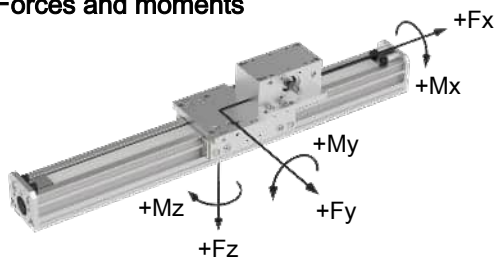

ARH	
Forces	Dynamic [N]
$F_x^{b)}$	1050
F_y	1350
F_z	1850
$-F_z$	1200
Moments	Dynamic [Nm]
M_x	50
M_y	120
M_z	110

b) Maximum value (see diagram „FX-v-Diagram“)

FX - v - Diagram

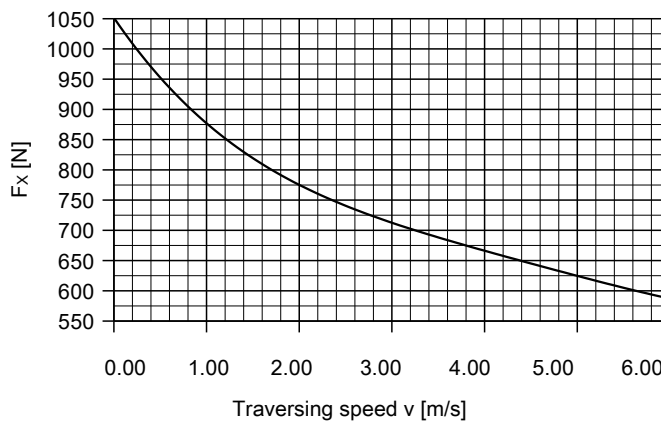

with toothed belt drive and roller guide (ARS)

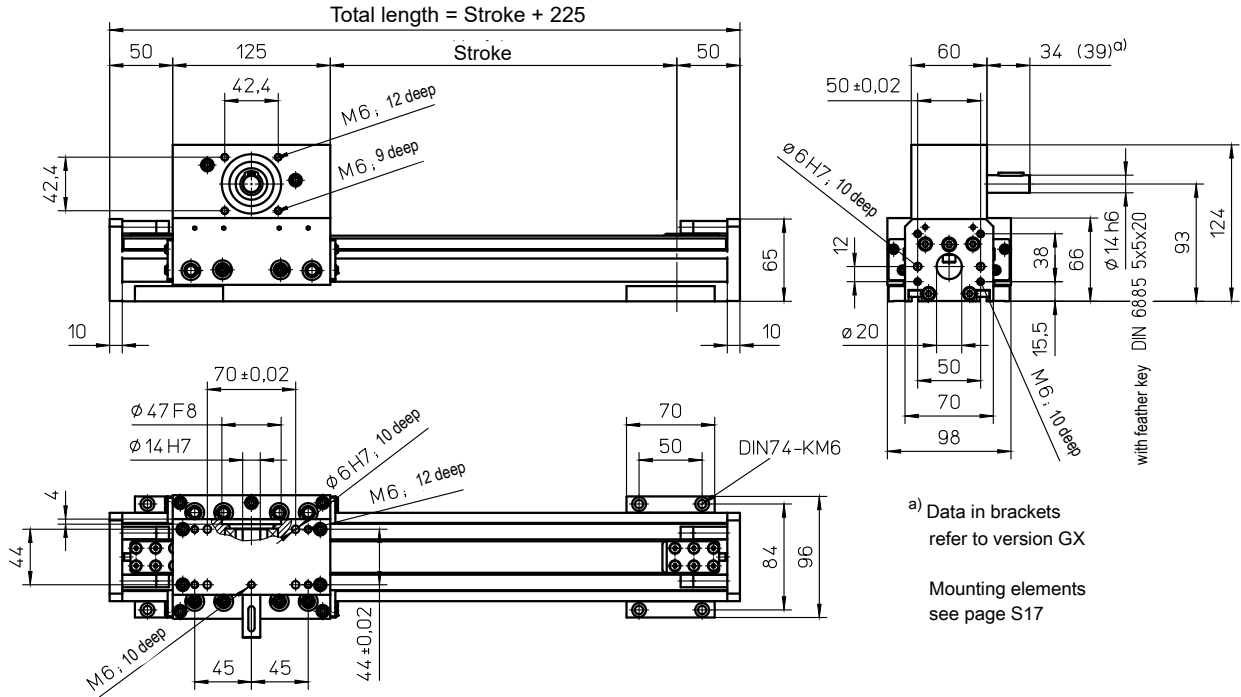

Weights ARS

Basic length without stroke:	3.50 kg
100 mm stroke:	0.40 kg
Entire carriage 125 mm:	2.30 kg
Max. total length:	8000 mm
(longer on request)	

Technical Data ARS

Max. speed:	6.25 m/s
Max. acceleration:	60 m/s ²
Repeat accuracy:	± 0.08 mm
Idle torque:	0.85 Nm
Moment of inertia:	5.37 · 10 ⁻⁵ kgm ²
(rotatory)	
Drive element:	Toothed belt 25 AT5-E
Stroke per revolution:	125 mm

Forces and moments

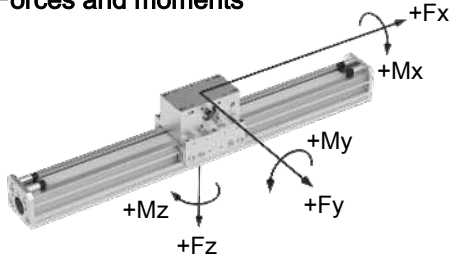

ARS	
Forces	Dynamic [N]
F _x ^{c)}	1050
F _y	1350
F _z	1850
-F _z	1200
Moments	Dynamic [Nm]
M _x	50
M _y	70
M _z	80

c) Maximum value (see diagram „FX-v-Diagram“)

FX - v - Diagram

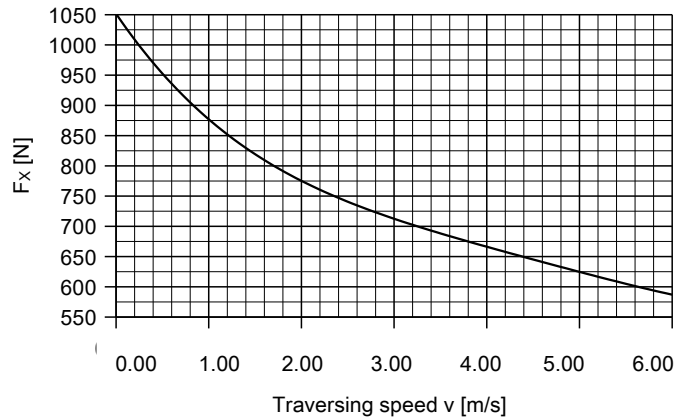

with toothed belt drive and roller guide (ZRS)

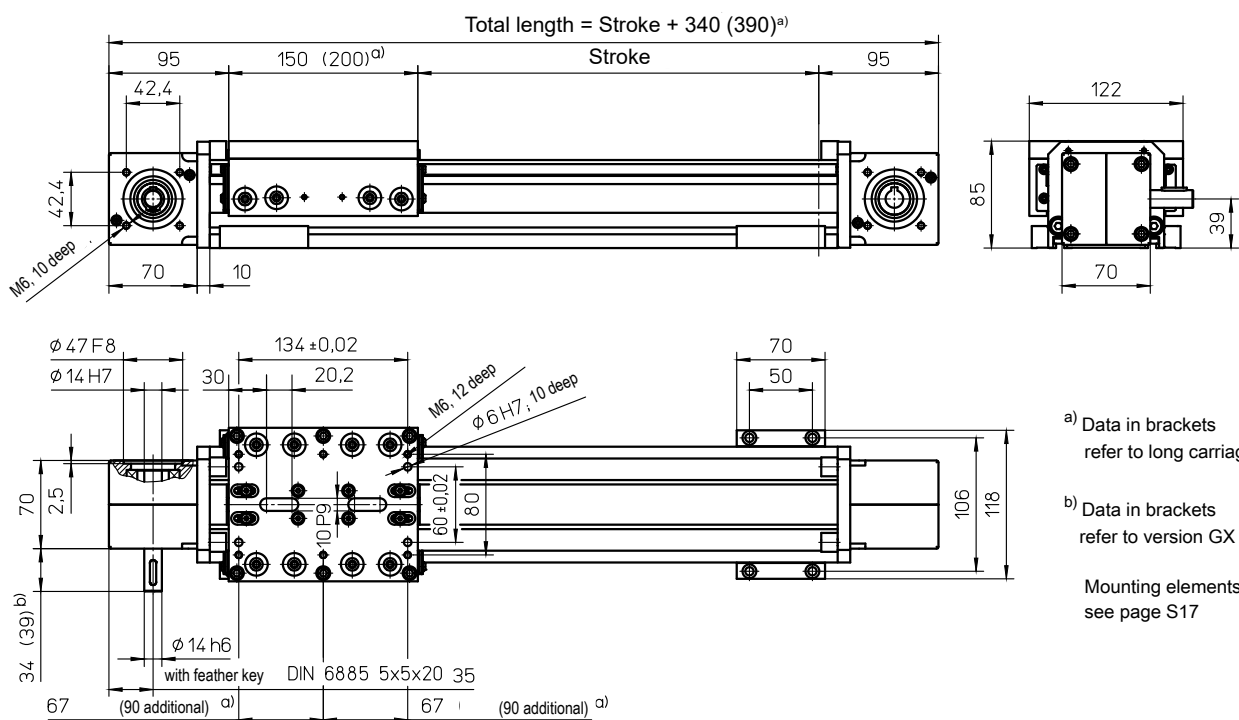

Weights

ZRS

Basic length without stroke:	5.10 kg
100 mm stroke:	0.65 kg
Entire carriage 150 mm:	2.00 kg
Entire carriage 200 mm:	2.40 kg
Max. total length: (longer on request)	8100 mm

Technical Data

ZRS

Max. speed:	8.00 m/s
Max. acceleration:	60 m/s ²
Repeat accuracy:	±0.08 mm
Idle torque:	3.20 Nm
Moment of inertia:	2.10 · 10 ⁻³ kgm ²
Drive element:	Toothed belt 32 AT5-E
Stroke per revolution:	175 mm

Forces and moments

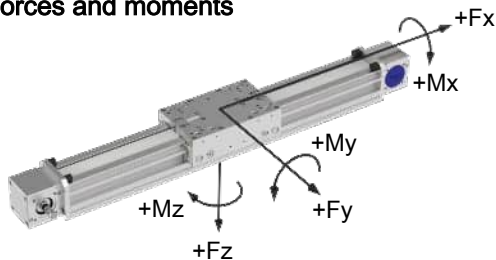

ZRS	
Forces	Dynamic [N]
$F_x^{c)}$	1300
F_y	2000
F_z	2500
$-F_z$	1500
Moments	Dynamic [Nm]
M_x	120
M_y	160 (230)
M_z	150 (200)

$F_x - v$ - Diagram

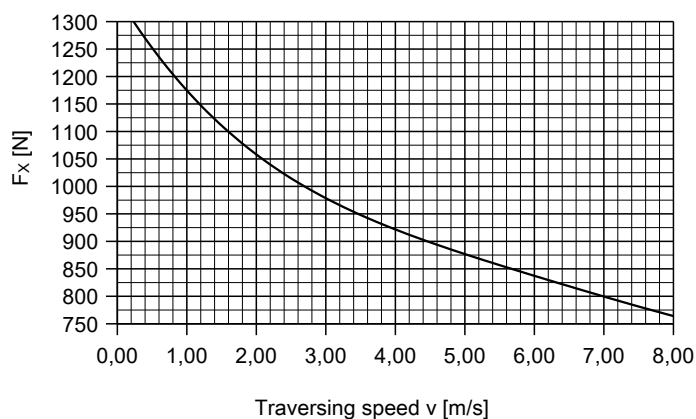

^{c)} Maximum value (see diagram „ $F_x - v$ -Diagram“)
 Data in brackets refer to long carriage (200)

with toothed belt drive and roller guide and a second independently travelling carriage (ZRSD)

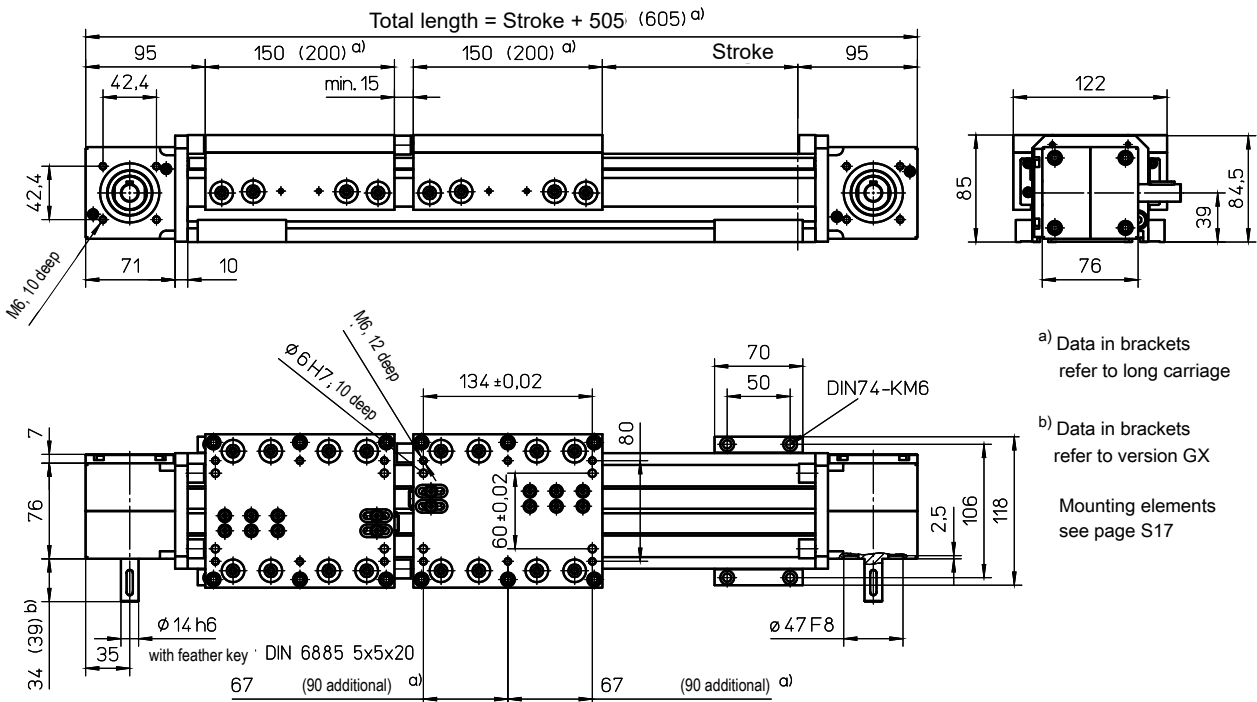

Weights

	ZRSD
Basic length without stroke:	8.40 kg
100 mm stroke:	0.65 kg
Entire carriage 150 mm:	1.80 kg
Entire carriage 200 mm:	2.15 kg
Max. total length: (longer on request)	8100 mm

Technical Data

	ZRSD
Max. speed:	8.00 m/s
Max. acceleration:	60 m/s ²
Repeat accuracy:	±0.08 mm
Idle torque:	3.20 Nm
Moment of inertia:	1.70 · 10 ⁻³ kgm ²
Drive element:	2 x Toothed belt 16 AT5-E
Stroke per revolution:	175 mm

Forces and moments

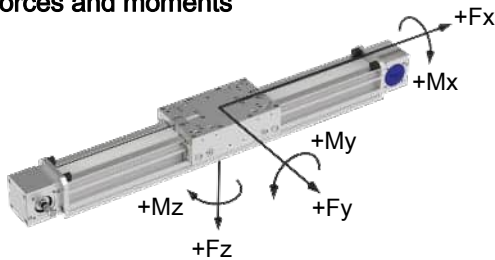

	ZRSD
Forces	Dynamic [N]
F_x^{c)}	650
F_y	2000
F_z	2500
-F_z	1500
Moments	Dynamic [Nm]
M_x	120
M_y	160 (230)
M_z	150 (200)

F_x - v - Diagram

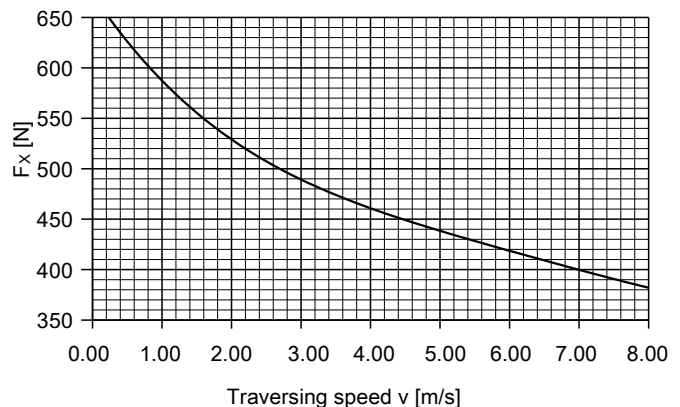

^{c)} Maximum value (see diagram „F_x-v-Diagram“)
Data in brackets refer to long carriage (200)

These data apply to each carriage.

with toothed belt drive and roller guide (ARH)

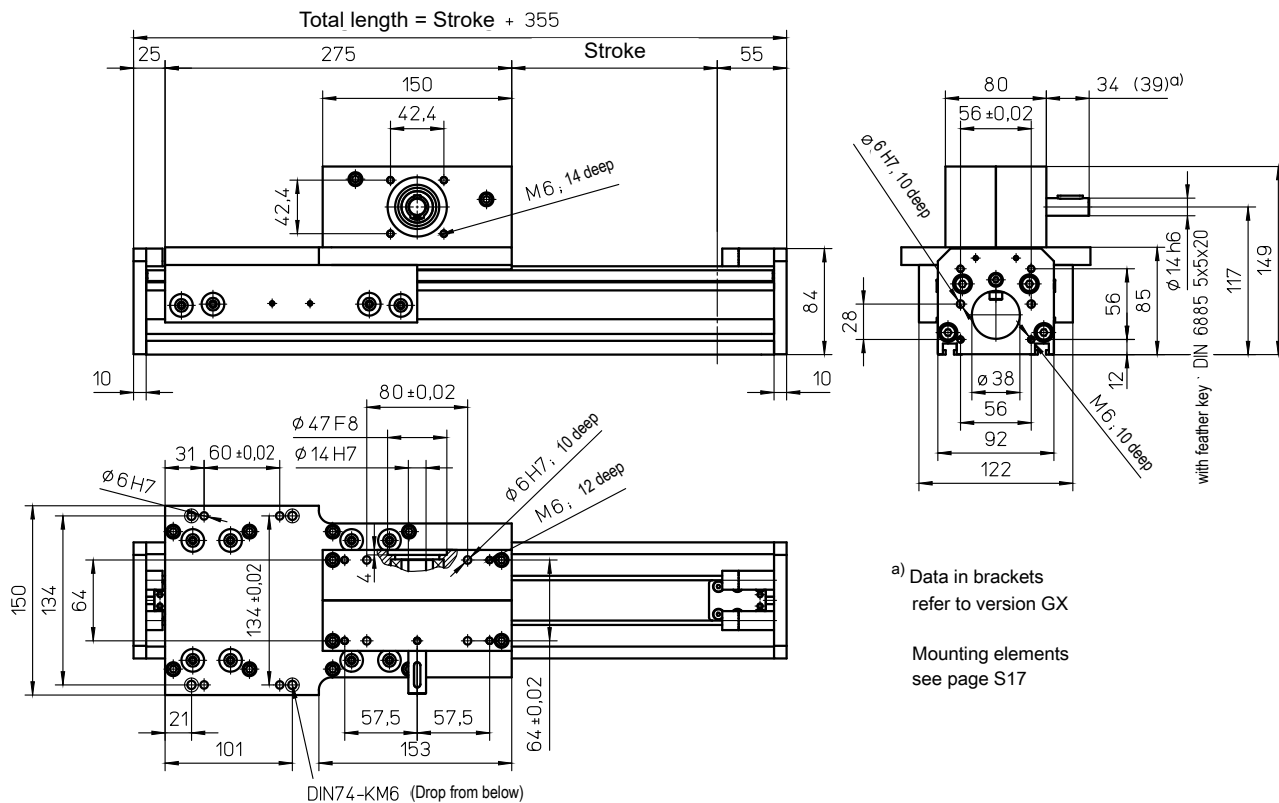

Weights

ARH

Basic length without stroke:	7.20 kg
100 mm stroke:	0.64 kg
Entire carriage 275 mm:	4.45 kg
Max. total length: (longer on request)	8000 mm

Technical Data

ARH

Max. speed:	7.0 m/s
Max. acceleration:	60 m/s ²
Repeat accuracy:	±0.08 mm
Idle torque:	2.30 Nm
Moment of inertia: (rotatory)	1.27 · 10 ⁻⁴ kgm ²
Drive element:	Toothed belt 32 AT5-E
Stroke per revolution:	150 mm

Forces and moments

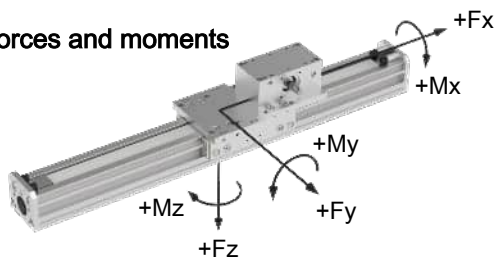

ARH	
Forces	Dynamic [N]
$F_x^{b)}$	1300
F_y	2000
F_z	2500
$-F_z$	1500
Moments	Dynamic [Nm]
M_x	120
M_y	230
M_z	200

b) Maximum value (see diagram „Fx-v-Diagram“)

Fx - v - Diagram

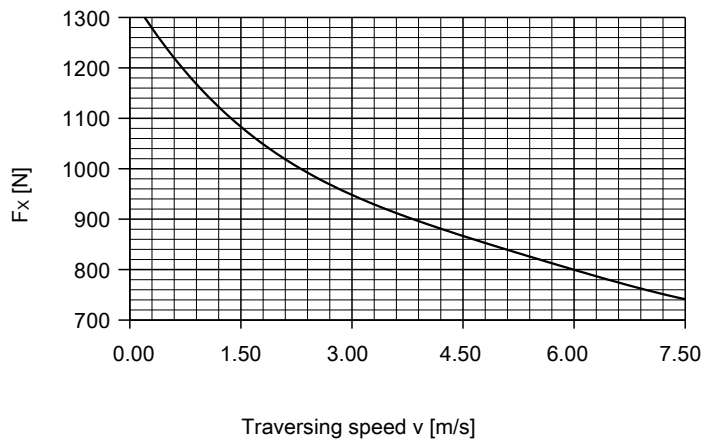

with toothed belt drive and roller guide (ARS)

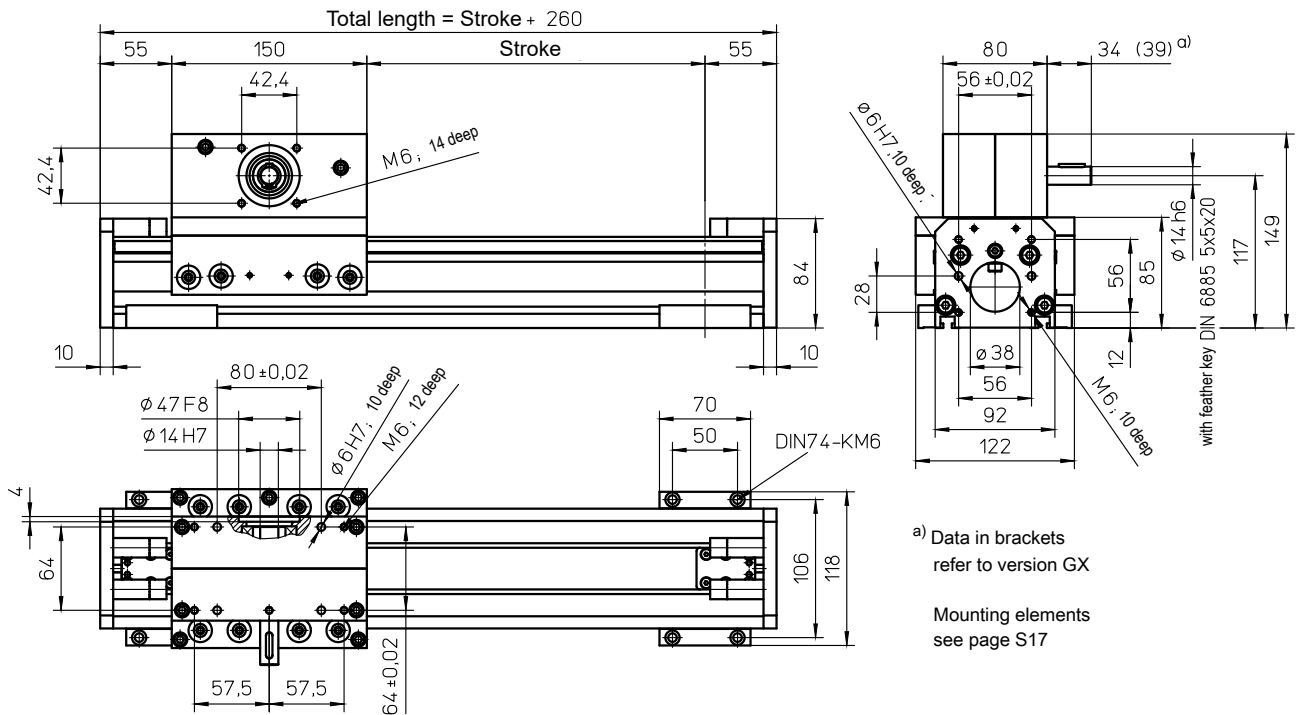

Weights

ARS

Basic length without stroke:	5.75 kg
100 mm stroke:	0.64 kg
Entire carriage 150 mm:	3.60 kg
Max. total length: (longer on request)	8000 mm

Technical Data

ARS

Max. speed:	7.50 m/s
Max. acceleration:	60 m/s ²
Repeat accuracy:	±0.08 mm
Idle torque:	2.30 Nm
Moment of inertia: (rotatory)	1.27 · 10 ⁻⁴ kgm ²
Drive element:	Toothed belt 32 AT5-E
Stroke per revolution:	150 mm

Forces and moments

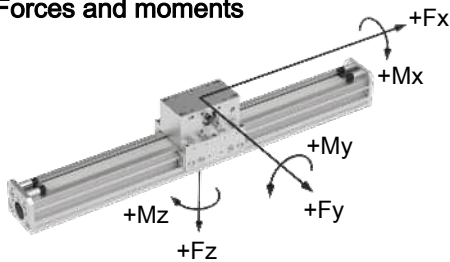

ARS	
Forces	Dynamic [N]
F _x ^{c)}	1300
F _y	2000
F _z	2500
-F _z	1500
Moments	Dynamic [Nm]
M _x	120
M _y	160
M _z	150

F_x - v - Diagram

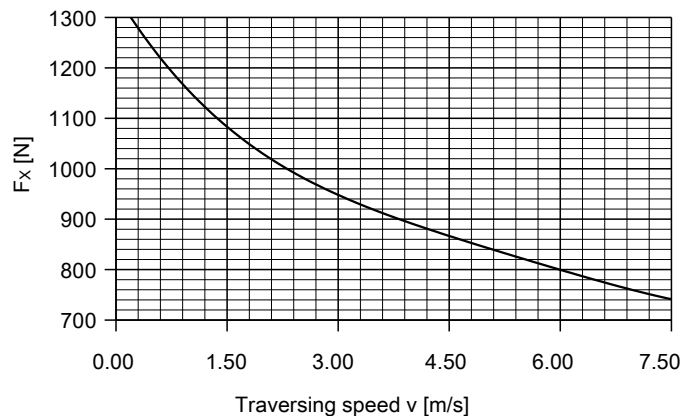

c) Maximum value (see diagram „F_x-v-Diagram“)

with toothed belt drive and roller guide (ZRS)

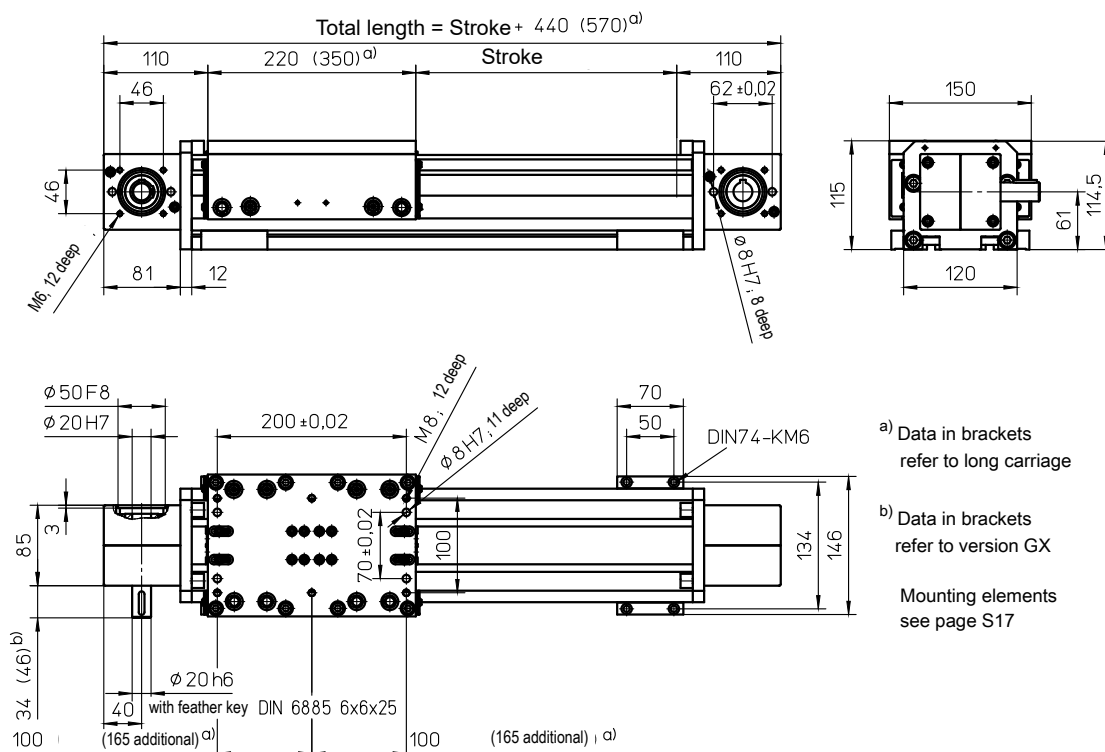

a) Data in brackets refer to long carriage
 b) Data in brackets refer to version GX
 Mounting elements see page S17

Weights

ZRS

Basic length without stroke:	10.90 kg
100 mm stroke:	1.20 kg
Entire carriage 220 mm:	3.85 kg
Entire carriage 350 mm:	5.40 kg
Max. total length: (longer on request)	8100 mm

Technical Data

ZRS

Max. speed:	8.00 m/s
Max. acceleration:	60 m/s ²
Repeat accuracy:	±0.08 mm
Idle torque:	3.00 Nm
Moment of inertia:	7.50 • 10 ⁻³ kgm ²
Drive element:	Toothed belt 40 AT10-E
Stroke per revolution:	200 mm

Forces and moments

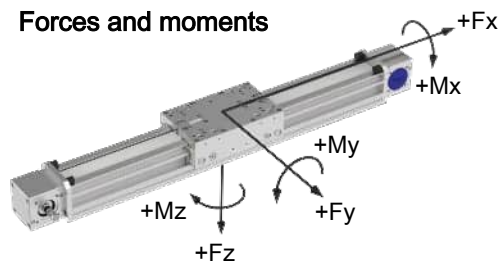

ZRS	
Forces	Dynamic [N]
$F_x^c)$	2800
F_y	2300
F_z	3000
$-F_z$	1800
Moments	Dynamic [Nm]
M_x	170
M_y	270 (400)
M_z	270 (400)

Fx - v - Diagram

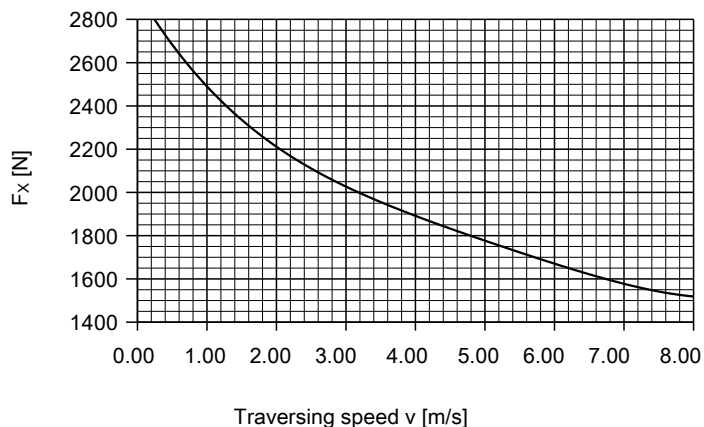

c) Maximum value (see diagram „Fx-v-Diagram“)
 Data in brackets refer to long carriage (350)

with toothed belt drive and roller guide and a second independently travelling carriage (ZRSD)

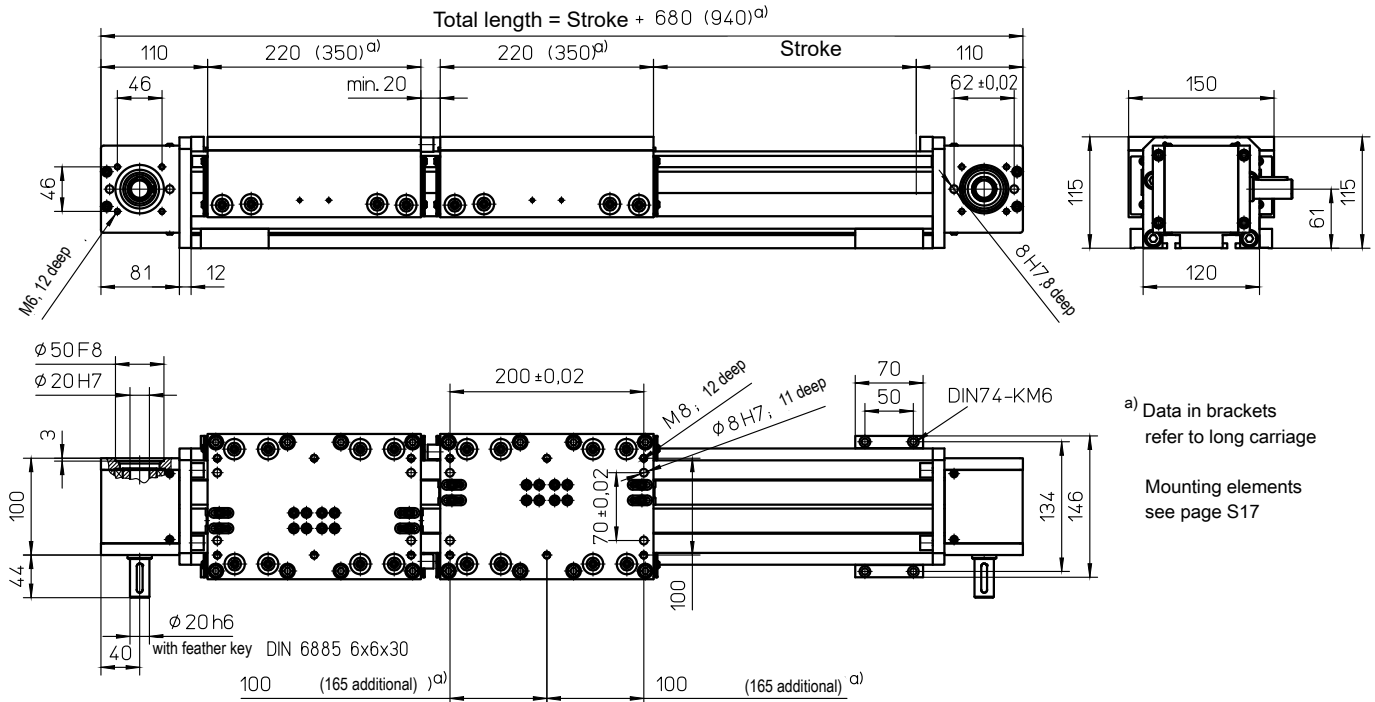

Weights

ZRSD

Basic length without stroke:	24.85 kg
100 mm stroke:	1.20 kg
Entire carriage 220 mm:	3.70 kg
Entire carriage 350 mm:	5.55 kg
Max. total length: (longer on request)	8100 mm

Technical Data

ZRSD

Max. speed:	8.00 m/s
Max. acceleration:	60 m/s ²
Repeat accuracy:	±0.08 mm
Idle torque:	3.00 Nm
Moment of inertia:	4.92 · 10 ⁻³ kgm ²
Drive element:	2 x Toothed belt 25 ATL10
Stroke per revolution:	200 mm

Forces and Moments

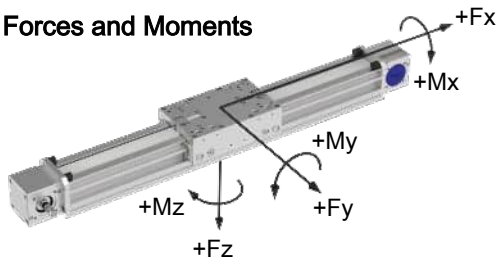

Forces	Dynamic [N]
F _x ^{b)}	1800
F _y	2300
F _z	3000
-F _z	1800
Moments	Dynamic [Nm]
M _x	170
M _y	270 (400)
M _z	270 (400)

F_x - v - Diagram

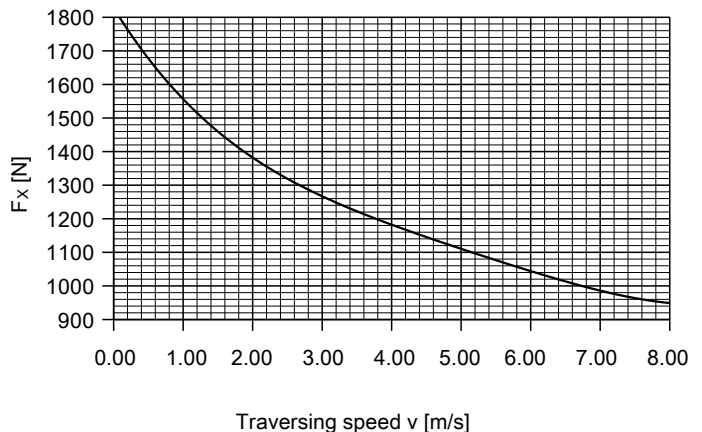

^{b)} Maximum value (see diagram „F_x-v-Diagram“)
Data in brackets refer to long carriage (350)

These data apply to each carriage.

with toothed belt drive and roller guide (ARS)

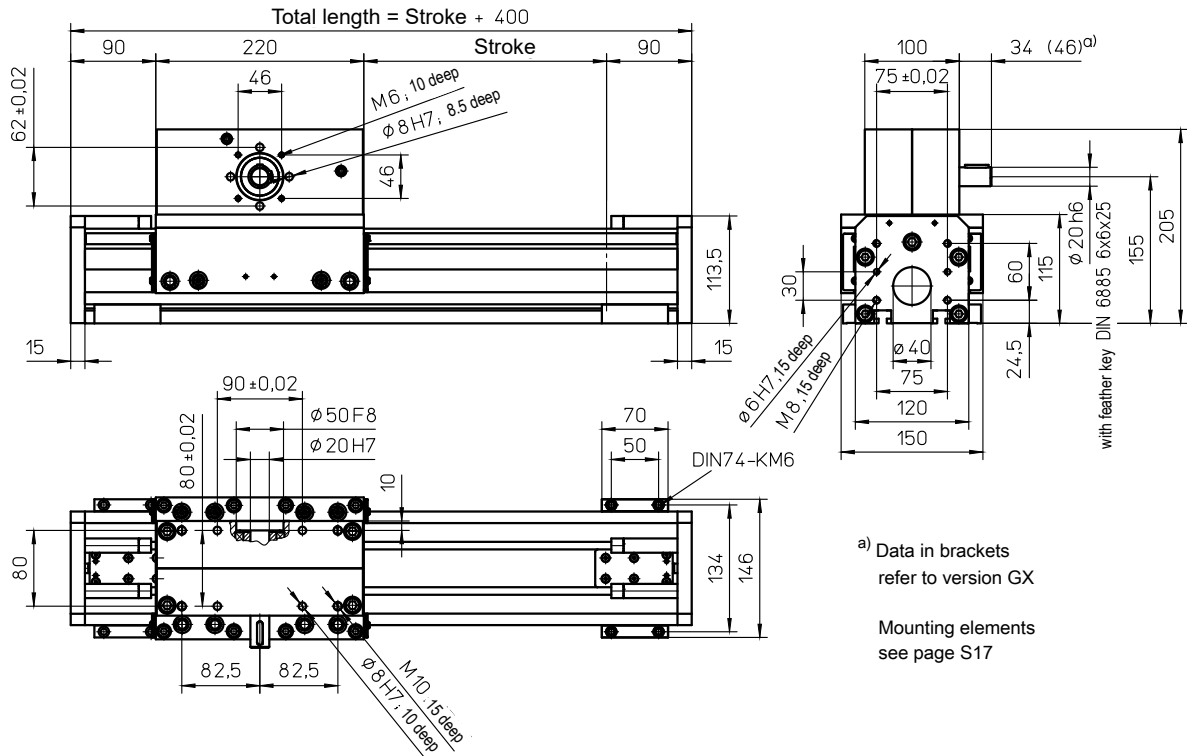

Weights

ARS

Basic length without stroke:	14.00 kg
100 mm stroke:	1.20 kg
Entire carriage 220 mm:	7.90 kg
Max. total length: (longer on request)	8000 mm

Technical Data

ARS

Max. speed:	8.00 m/s
Max. acceleration:	60 m/s ²
Repeat accuracy:	±0.08 mm
Idle torque:	3.80 Nm
Moment of inertia: (rotatory)	7.90 · 10 ⁻⁴ kgm ²
Drive element:	Toothed belt 40 AT10-E
Stroke per revolution:	240 mm

Forces and moments

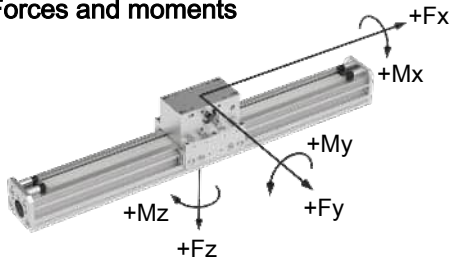

ARS	
Forces	Dynamic [N]
$F_x^{b)}$	3200
F_y	2300
F_z	3000
$-F_z$	1800
Moments	Dynamic [Nm]
M_x	170
M_y	270
M_z	270

$F_x - v$ - Diagram

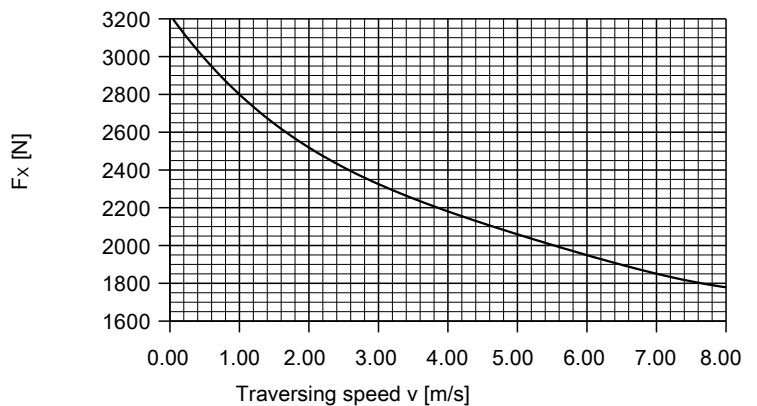

^{b)} Maximum value (see diagram „ F_x-v -Diagram“)

with toothed belt drive and roller guide (ZRS)

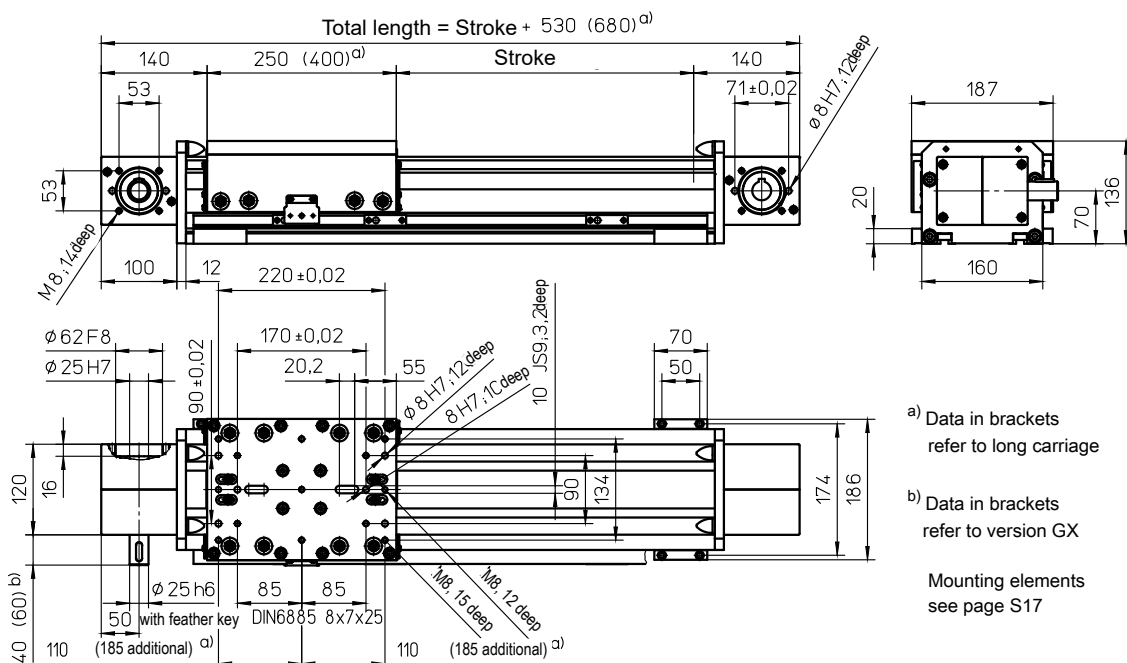

Weights

ZRS

Basic length without stroke:	17.65 kg
100 mm stroke:	1.67 kg
Entire carriage 250:	5.95 kg
Entire carriage 400 mm:	8.75 kg
Max. total length: (longer on request)	6100 mm

Technical Data

ZRS

Max. speed:	8.00 m/s
Max. acceleration:	60 m/s ²
Repeat accuracy:	±0.08 mm
Idle torque:	4.00 Nm
Moment of inertia:	1.23 · 10 ⁻² kgm ²
Drive element:	Toothed belt 50 ATL10
Stroke per revolution:	240 mm

Forces and moments

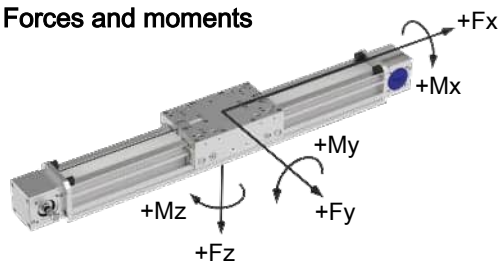

ZRS	
Forces	Dynamic [N]
F _x ^{c)}	4000
F _y	4500
F _z	6000
-F _z	4000
Moments	Dynamic [Nm]
M _x	500
M _y	700 (1000)
M _z	700 (1000)

F_x - v - Diagram

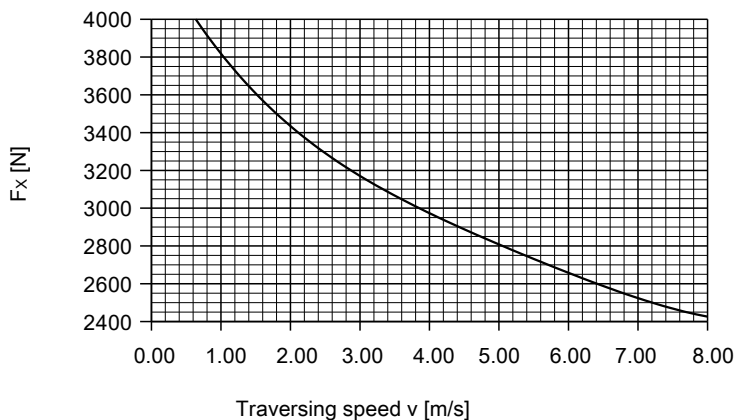

^{c)} Maximum value (see diagram „F_x-v-Diagram“)
Data in brackets refer to long carriage (400)

with toothed belt drive and roller guide and a second independently travelling carriage (ZRSD)

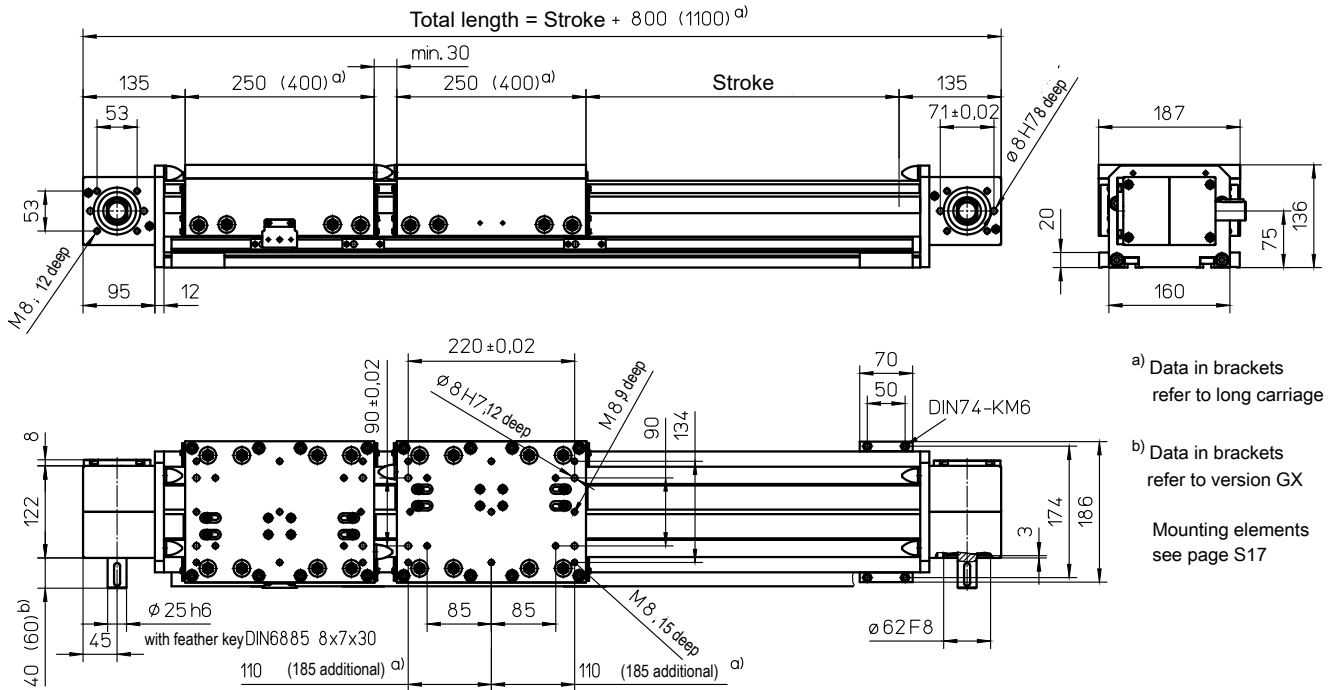

Weights

ZRSD

Basic length without stroke:	28.10 kg
100 mm stroke:	1.68 kg
Entire carriage 250 mm:	5.75 kg
Entire carriage 400 mm:	8.30 kg
Max. total length: (longer on request)	6100 mm

Technical data

ZRSD

Max. speed:	8.00 m/s
Max. acceleration:	60 m/s ²
Repeat accuracy:	±0.08 mm
Idle torque:	3.50 Nm
Moment of inertia:	7.16 · 10 ⁻³ kgm ²
Drive element:	2 x Toothed belt 32 AT10
Stroke per revolution:	210 mm

Forces and moments

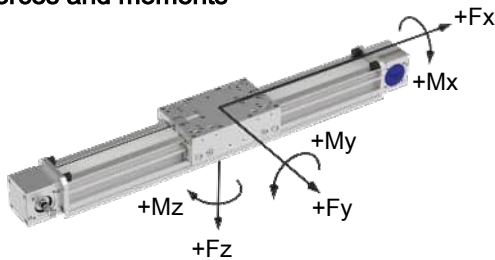

ZRSD	
Forces	Dynamic [N]
F _x ^{c)}	2300
F _y	4500
F _z	6000
-F _z	4000
Moments	Dynamic [Nm]
M _x	500
M _y	700 (1000)
M _z	700 (1000)

F_x - v - Diagram

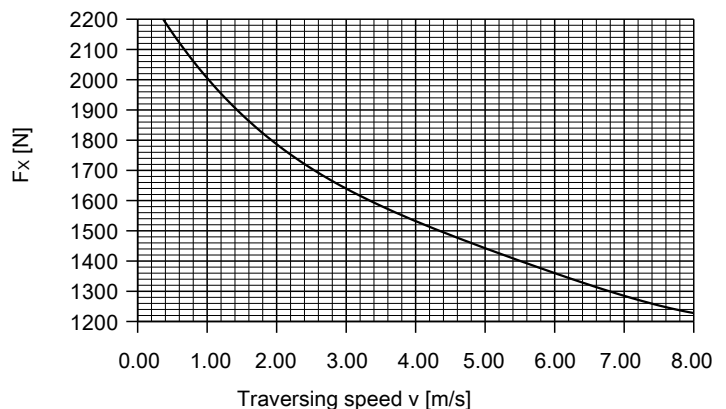

^{c)} Maximum value (see diagram „F_x-v-Diagram“)
Data in brackets refer to long carriage (400)

These data apply to each carriage.

with toothed belt drive an roller guide (ARH)

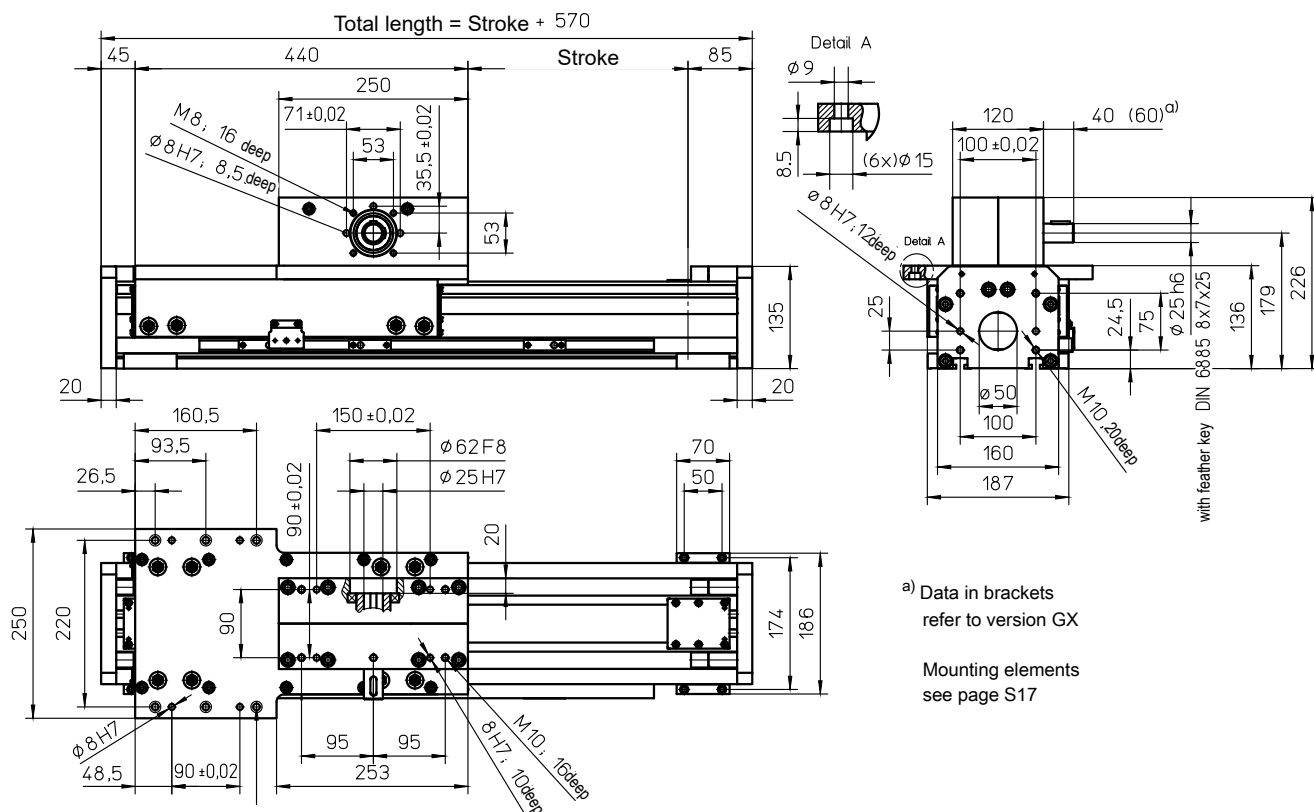

Weights

	ARH
Basic length without stroke:	27.30 kg
100 mm stroke:	1.63 kg
Entire carriage 440 mm:	14.65 kg
Max. total length: (longer on request)	6000 mm

Technical Data

	ARH
Max. speed:	8.00 m/s
Max. acceleration:	60 m/s ²
Repeat accuracy:	±0.08 mm
Idle torque:	4.20 Nm
Moment of inertia: (rotatory)	1.50 · 10 ⁻³ kgm ²
Drive element:	Toothed belt 50 AT10-E
Stroke per revolution:	240 mm

Forces and moments

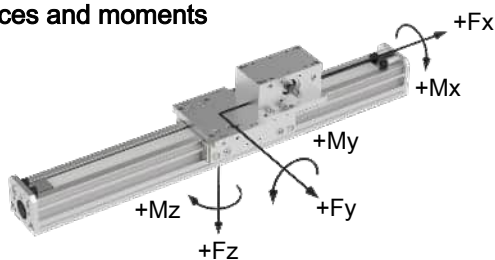

	ARH
Forces	Dynamic [N]
F _x ^{b)}	4000
F _y	4500
F _z	6000
-F _z	4000
Moments	Dynamic [Nm]
M _x	500
M _y	1000
M _z	1000

F_x - v - Diagram

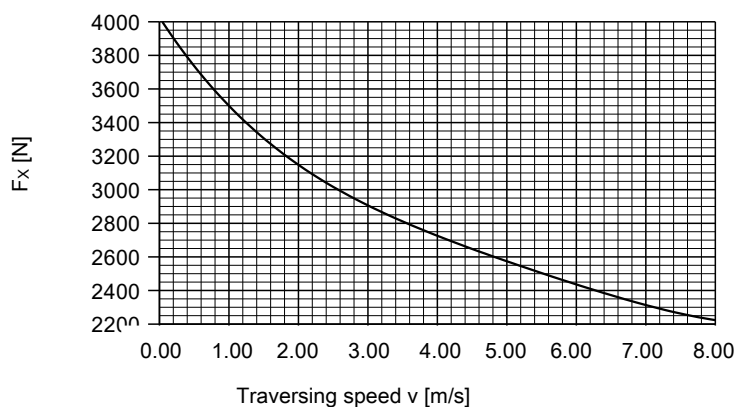

^{b)} Maximum value (see diagram „F_x-v-Diagram“)

with toothed belt drive and roller guide (ARS)

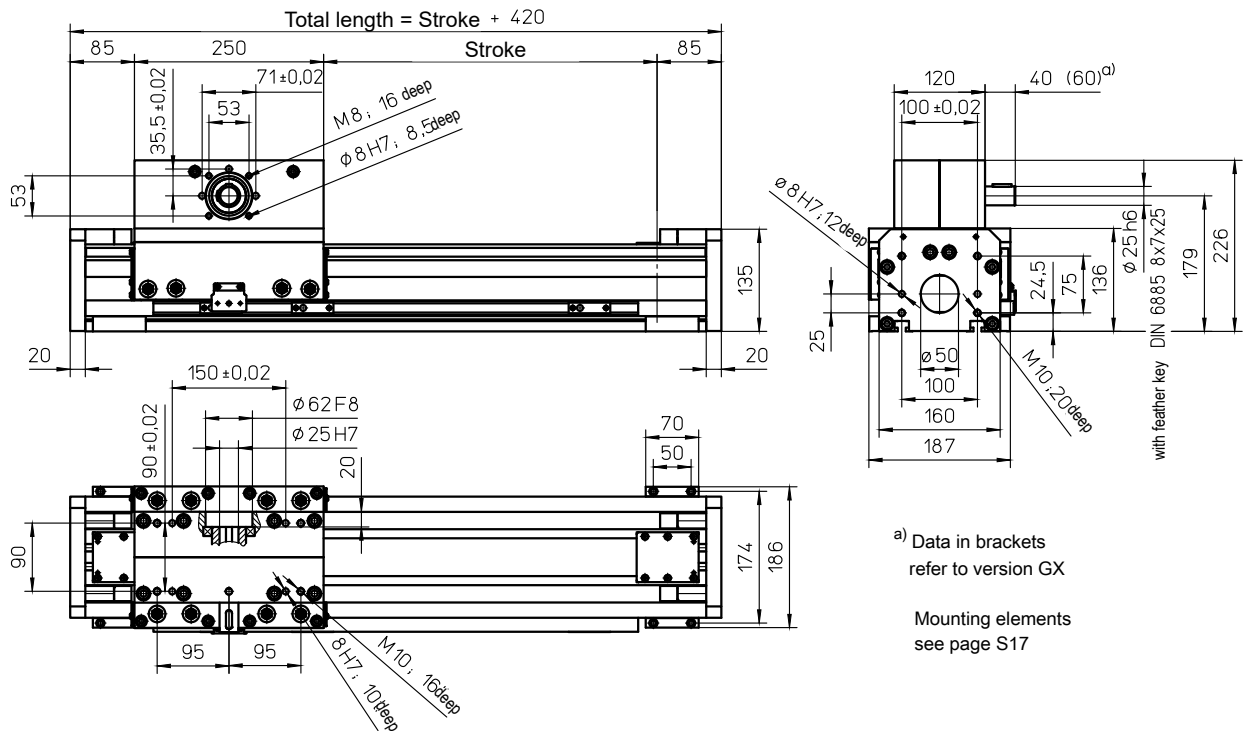

Weights

ARS

Basic length without stroke:	21.25 kg
100 mm stroke:	1.63 kg
Entire carriage 250 mm:	11.20 kg
Max. total length: (longer on request)	6000 mm

Technical Data

ARS

Max. speed:	8.00 m/s
Max. acceleration:	60 m/s ²
Repeat accuracy:	±0.08 mm
Idle torque:	4.20 Nm
Moment of inertia: (rotatory)	1.50 · 10 ⁻³ kgm ²
Drive element:	Toothed belt 50 AT10-E
Stroke per revolution:	240 mm

Forces and moments

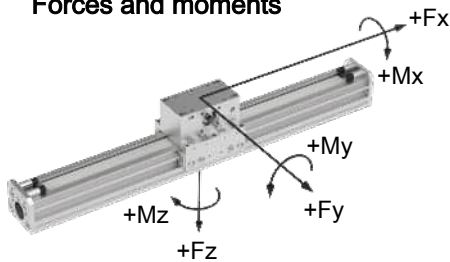

ARS	
Forces	Dynamic [N]
F _x ^{c)}	4000
F _y	4500
F _z	6000
-F _z	4000
Moments	Dynamic [Nm]
M _x	500
M _y	700
M _z	700

^{c)} Maximum value (see diagram „Fx-v-Diagram“)

Fx - v - Diagram

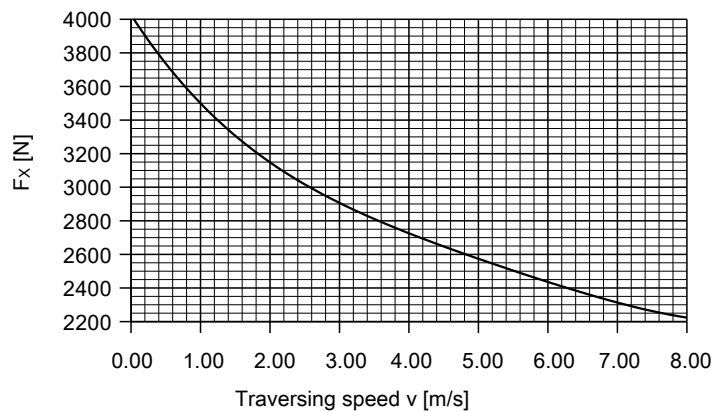

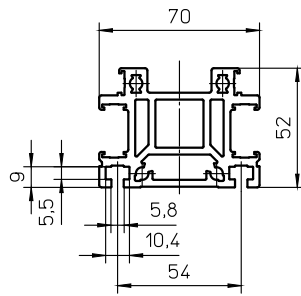

Profile Sigma 70

Specific mass [kg/m]	3.31
Surface measure [mm ²]	1227
Geometrical moment of inertia I _y [mm ⁴]	311463
Geometrical moment of inertia I _z [mm ⁴]	506501
Section modulus W _y [mm ³]	11006
Section modulus W _z [mm ³]	14471

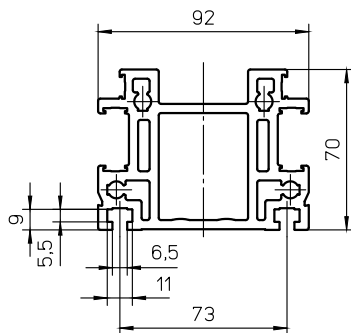

Profile Sigma 90

Specific mass [kg/m]	5.69
Surface measure [mm ²]	2108
Geometrical moment of inertia I _y [mm ⁴]	1011977
Geometrical moment of inertia I _z [mm ⁴]	1806496
Section modulus W _y [mm ³]	26583
Section modulus W _z [mm ³]	39272

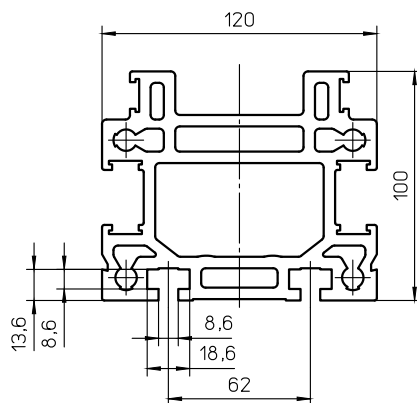

Profile Sigma 120

Specific mass [kg/m]	10.92
Surface measure [mm ²]	4044
Geometrical moment of inertia I _y [mm ⁴]	4001551
Geometrical moment of inertia I _z [mm ⁴]	5857612
Section modulus W _y [mm ³]	74232
Section modulus W _z [mm ³]	97627

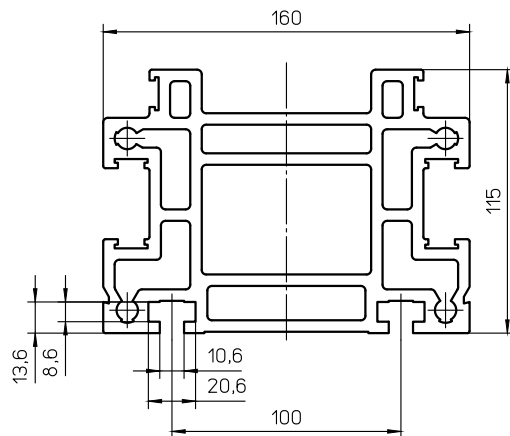

Profile Sigma 160

Specific mass [kg/m]	15.08
Surface measure [mm ²]	5583
Geometrical moment of inertia I _y [mm ⁴]	7080449
Geometrical moment of inertia I _z [mm ⁴]	14157096
Section modulus W _y [mm ³]	114660
Section modulus W _z [mm ³]	176964

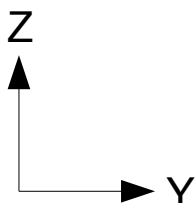

NS 2..21

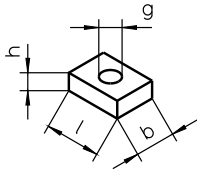

RM 2 / 6

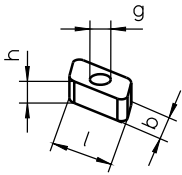

Linear drive	Page *	NS	ID No.	l [mm]	b [mm]	h [mm]	g
Sigma 70	E	2	10557	16	10	4	M5
Sigma 90	E	2	10557	16	10	4	M5
		21	22955	20	10	5	M6
Sigma 120	E	RM2	15370	10	6	4	M4
		19	10559	18	14	6	M8
		20	10560	20	14	8	M8
Sigma 160	E	10	16499	20	13	6	M6
		6	10561	25	18	8	M10
		20	23949	20	16	8	M8
		RM6	15372	18	10	8	M6

BL 1 / 2

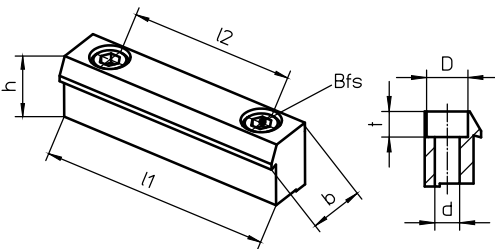

Linear drive	BL	ID No.	l1 [mm]	l2 [mm]	b [mm]	h [mm]	Bfs	D [mm]	d [mm]	t [mm]
Sigma 70	11	25267	70	50	13	12	M6	11	6,6	6,8
Sigma 90	1	10552	70	50	15	17,5	M6	11	6,6	6,8
Sigma 120	2	10553	70	50	15	20	M6	11	6,6	6,8
Sigma 160	2	10553	70	50	15	20	M6	11	6,6	6,8

* For further information on pages C – E, see page Z1
 Bfs = Mounting screw DIN 912 / ISO 4762

Example:

Sigma 120-ZRS-40 AT10-200-1000-1440-AZ1-6NS5-1

Product

Size

Drive

Z = Toothed belt drive

0 = Without drive

A = Powered carriage

Guide system

R = Roller guide

Model

ZRS = Standard (Horizontal)

ZRSD = Standard double (Horizontal)

ARH = Lifting axis (Vertical)

ARS = Standard (Horizontal)

Drive specifications

Width of toothed belt and tooth pitch

Stroke per revolution

Stroke

Total length

Accessories

AZ1 = Drive shaft short, mounting side **C**

AZ2 = Drive shaft short, mounting side **D**

AZ6 = Drive shaft long, mounting side **C** and **D**

Further arrangements for drive shaft, see **page Z1**

EO2 / EO10 = Inductive limit switch with 2 m/10 m cable fitted

ES2 / ES10 = Inductive limit switch with 2 m/10 m cable fitted

EMS / EMB = Mechanical limit switch (S = Siemens, B = Balluff) fitted

BL = Mounting bracket

NS / RM = Sliding block 2 .. 10 / Rhomb nut 2 .. 6 (See Table on **page S17**)

Special design

0 = Standard

1 = Special (add specification description)

Further accessories (separate position)

MGK = Motor mounting and coupling (according to dimension sheet)

Chapter Z

Accessories

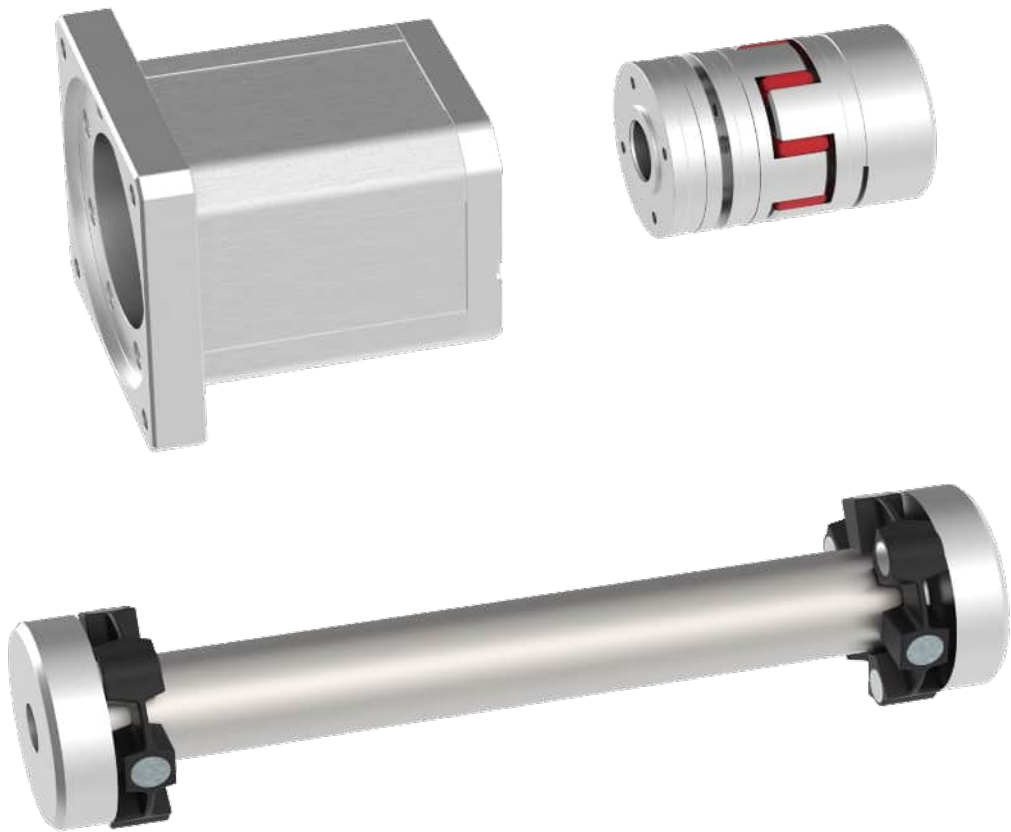

Ordering code for limit switch positions, limit switch type (EN),
lubrication ports and drive shafts (AZ) and wiper versions

Limit switch position

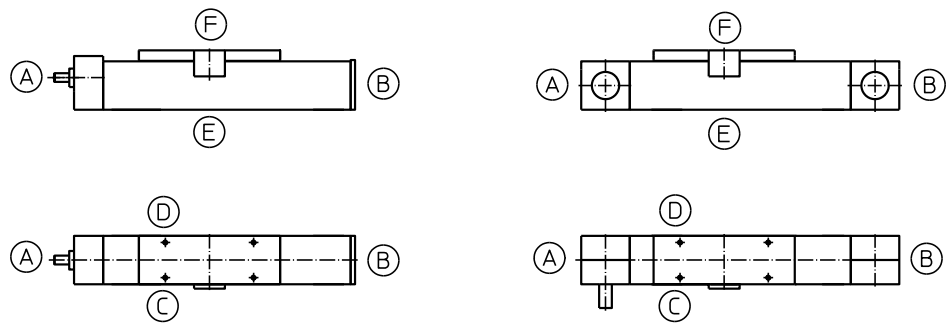

Limit switch types (EN)

- EO2 = Inductive proximity switch "Normally Closed" with 2 m cable (33003)
- EO10 = Inductive proximity switch "Normally Closed" with 10 m cable (10401)
- ES2 = Inductive proximity switch "Normally Open" with 10 m cable (10402)
- ES10 = Inductive proximity switch "Normally Open" with 2 m cable (10403)
- EMS / EMB = Mechanical limit switch "normally closed" (S = Siemens, B = Balluff; without cable)

Insofar as there are no other specifications provided, the limit switches are fitted as follows (standard):

1. Switch: **EO2** NC with 2 m cable on page C, pos. A, cable exit at A
Switching point = Mechanical end position
2. Switch: **EO2** NC with 2 m cable on page C, pos. B, cable exit at B
Switching point = Mechanical end position
3. Switch: **ES2** NO with 2 m cable on page C, pos. A, cable exit at A
Switching point = Directly beside first switch (as reference)

Lubrication ports

Standard Beta, Delta-C and Alpha: Lubricating nipple M8x1, page C + D
(exception: Delta = M6; Beta 40, Beta 70-C-ARS-ASS = drive in lubrication nipple)

Drive shafts (AZ)

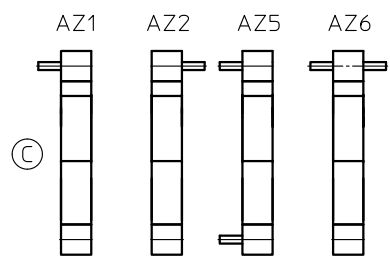

Wiper versions

(Design is based on carriage plate)

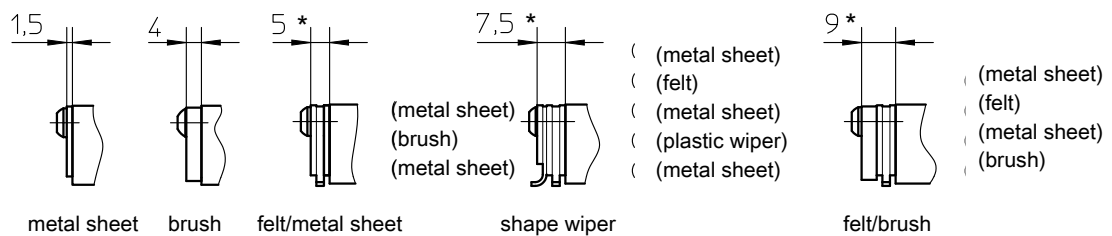

* Bei Beta 165(-C) und Beta 180(-C) + 2 mm

Deflection belt drive mounting (URT)

URT can be turned 90° when mounted

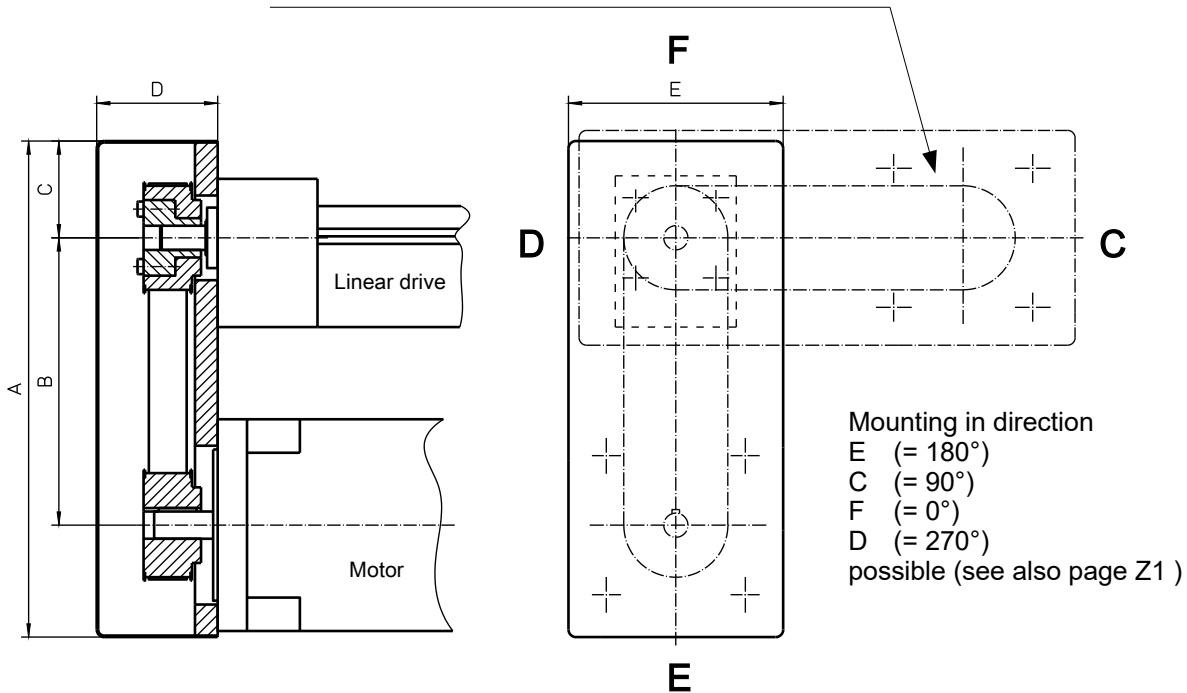

Linear drive version			URT version	A	B*	C	D	E
Beta 40 Beta 50-C	Delta 90 Delta 110		URT 1	195	105 ±10	41	45	90
Beta 60 Beta 70-C	Delta 145-C	Alpha 15-B	URT 2	238	120 ±10	46	52	102
Beta 80(-C) Beta 100-D Beta 110 Beta 120-C Beta 140(-C) Beta 165(-C) Beta 180(-C)	Delta 200 Delta 240	Alpha 20-B Alpha 30-B Alpha 35-B	URT 3	328	190 ±10	64	80	142

* Centre distance B: depending on ratio and toothed belt

Possible gear ratios:

$i = 1:1$

$i = 2:1$

$i = 3:1^{**}$

Note: Depending on the motor shaft diameter and necessary drive moment, all ratios may not be possible

** maximum possible motor shaft diameter with shaft without feather key:

URT 1: not possible

URT 2: 11

URT 3: 15

Motor mounting shown in direction E (= 180°) (dashed C (= 90°))

Bevel gear mounting (KRG)

Unit size	Gear types	Version	Ratio	b	l2	l3	l4	n	s	t
Beta 40	V065	E0N0, K0N0	1:1 ... 3:1	65	11	53	95	42	M6	54
Beta 50-C	V065	E0N0, K0N0	1:1 ... 3:1	65	11	53	95	42	M6	54
Beta 60	V065	E0N0, K0N0	1:1 ... 3:1	65	16	58	100	42	M6	54
Beta 60-SGV	V065	E0N0, K0N0	1:1 ... 3:1	65	16	58	100	42	M6	54
Beta 70-C	V065	E0N0, K0N0	1:1 ... 3:1	65	16	58	100	42	M6	54
Beta 80	V090	E0N0, K0N0	1:1 ... 6:1	90	20	75	130	55	M8	75
Beta 100-D	V090	E0N0, K0N0	1:1 ... 6:1	90	20	75	130	55	M8	75
Beta 110	V090	E0N0, K0N0	1:1 ... 6:1	90	20	75	130	55	M8	75
Beta 110-C-SGV	V120	E0N0, K0N0	1:1 ... 6:1	120	30	102	174	75	M10	100
Beta 120-C	V120	E0N0, K0N0	1:1 ... 6:1	120	30	102	174	75	M10	100
Beta 140(-C)	V090	E0N0, K0N0	1:1 ... 6:1	90	20	75	130	55	M8	75
Beta 165(-C)	V120	E0N0, K0N0	1:1 ... 6:1	120	30	102	174	75	M10	100
Beta 180(-C)	V120	E0N0, K0N0	1:1 ... 6:1	120	30	102	174	75	M10	100
Delta 90	V065	E0N0, K0N0	1:1 ... 3:1	65	16	58	100	42	M6	54
Delta 110-C	V065	E0N0, K0N0	1:1 ... 3:1	65	18	58	100	42	M6	54
Delta 145-C	V090	B0,C0,G0,H0	1:1 ... 6:1	90	94	149	204	55	M8	75
Delta 200	V120	B0,C0,G0,H0	1:1 ... 6:1	120	112	184	256	75	M10	100
Delta 240(-C)	V120	B0,C0,G0,H0	1:1 ... 6:1	120	112	184	256	75	M10	100
Alpha 15-B-155	V065	E0N0, K0N0	1:1 ... 3:1	65	16	58	100	42	M6	54
Alpha 20-B-225	V090	E0N0, K0N0	1:1 ... 6:1	90	20	75	130	55	M8	75
Alpha 30-B-325	V090	E0N0, K0N0	1:1 ... 6:1	90	20	75	130	55	M8	75
Alpha 35-B-455	V120	E0N0, K0N0	1:1 ... 6:1	120	30	102	174	75	M10	100

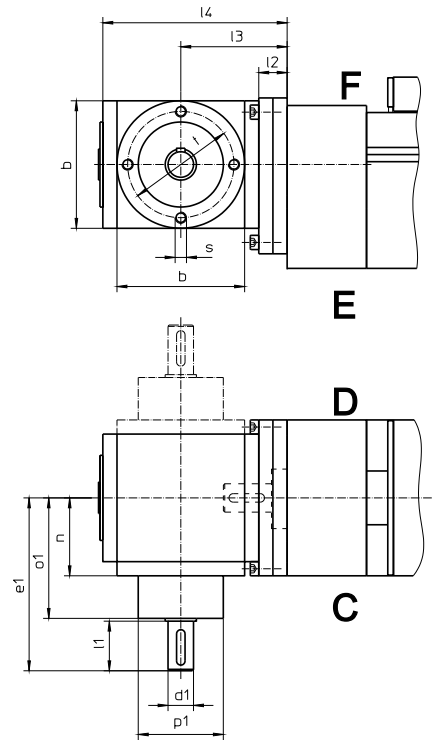

Motor mounting side "C", "D", "E" or "F" (see also page Z1)

Ratio	1:1 – 2:1					3:1					4:1					5:1 – 6:1					
	d1	l1	e1	o1	p1	d1	l1	e1	o1	p1	d1	l1	e1	o1	p1	d1	l1	e1	o1	p1	
Beta 40	12	26	100	72	44	12	26	100	72	44											
Beta 50-C	12	26	100	72	44	12	26	100	72	44											
Beta 60	12	26	100	72	44	12	26	100	72	44											
Beta 60-SGV	12	26	100	72	44	12	26	100	72	44											
Beta 70-C	12	26	100	72	44	12	26	100	72	44											
Beta 80	18	35	122	85	60	12	35	122	85	60	12	35	132	95	60	12	35	132	95	60	60
Beta 100-D	18	35	122	85	60	12	35	122	85	60	12	35	132	95	60	12	35	132	95	60	60
Beta 110	18	35	122	85	60	12	35	122	85	60	12	35	132	95	60	12	35	132	95	60	60
Beta 110-C-SGV	25	45	162	115	80	20	45	162	115	80	20	45	172	125	80	15	35	162	125	70	70
Beta 120-C	25	45	162	115	80	20	45	162	115	80	20	45	172	125	80	15	35	162	125	70	70
Beta 140(-C)	18	35	122	85	60	12	35	122	85	60	12	35	132	95	60	12	35	132	95	60	60
Beta 165(-C)	25	45	162	115	80	20	45	162	115	80	20	45	172	125	80	15	35	162	125	70	70
Beta 180(-C)	25	45	162	115	80	20	45	162	115	80	20	45	172	125	80	15	35	162	125	70	70
Delta 90	12	26	100	72	44	12	26	100	72	44											
Delta 110-C	12	26	100	72	44	12	26	100	72	44											
Delta 145-C	18	35	122	85	60	12	35	122	85	60	12	35	132	95	60	12	35	132	95	60	60
Delta 200	25	45	162	115	80	20	45	162	115	80	20	45	172	125	80	15	35	162	125	70	70
Delta 240(-C)	25	45	162	115	80	20	45	162	115	80	20	45	172	125	80	15	35	162	125	70	70
Alpha 15-B-155	12	26	100	72	44	12	26	100	72	44											
Alpha 20-B-225	18	35	122	85	60	12	35	122	85	60	12	35	132	95	60	12	35	132	95	60	60
Alpha 30-B-325	18	35	122	85	60	12	35	122	85	60	12	35	132	95	60	12	35	132	95	60	60
Alpha 35-B-455	25	45	162	115	80	20	45	162	115	80	20	45	172	125	80	15	35	162	125	70	70

All bevel gears are lubricated for life with synthetic oil (lubrication B0). Maximum duty cycle 40 %.

For a longer duty cycle, please order "lubrication B1" and specify mounting position. Angular play <20 minutes.

Versions:

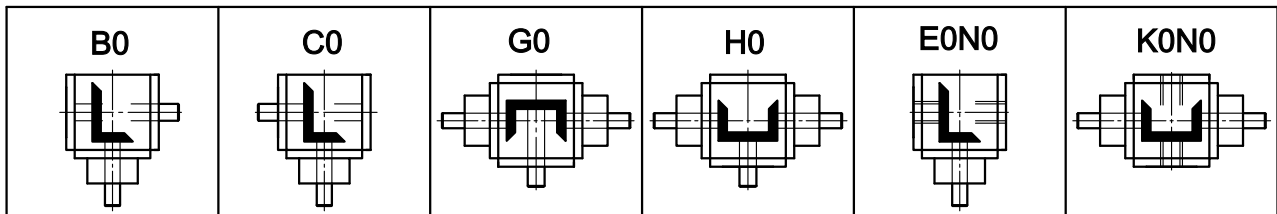

(Pay attention to diameter of sleeve shaft of version E0N0 / K0N0.)

Allowed output nominal torque (Nm) at input rotation speed 3000 min⁻¹

Atek-Gears

Gear	Ratio i							Ø Sleeve shafts of Version E0N0 / K0N0
	1:1	1,5:1	2:1	3:1	4:1	5:1	6:1	
065	10	10	10	10	-	-	-	12
090	27	25	23	23	23	23	23	18
120	66	61	56	58	60	60	54	25

Nidec Graessner-Gears

Power Gear	Ratio i					
	1:1	1,5:1	2:1	3:1	4:1	5:1
P54	15	15	12	12	-	-
P75	45	45	42	33	28	25
P90	78	78	68	54	52	40
P110	150	150	150	120	100	85

At allowed values there are only limited** thermal limiting performances considered.
This applies to both producers.
Details see documentation of producers (Atek and Nidec Graessner).

** switch-on time ED = 40 %, rotation speed 3000 U/min, ambient temperature 20 °C

Joint shaft mounting (GX)

Toothed belt drive

Threaded spindle drive

Dimension AA = Centre distance between mechanical linear drives

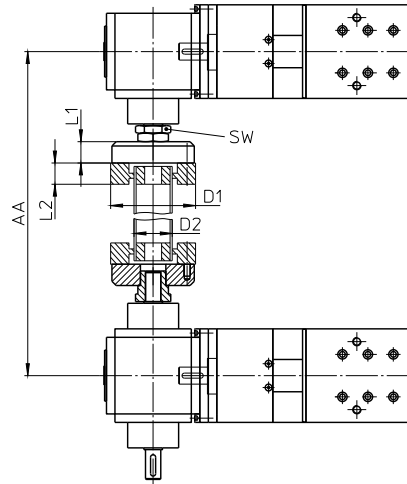
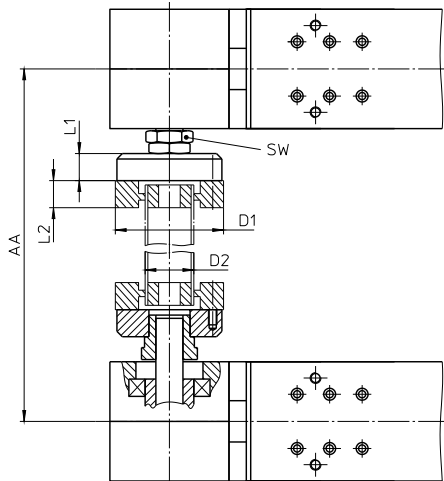

Linear Drive	Size	Moment max. [Nm]	AA min.	SW
Beta 40-ZSS	GX1	8	159	22
Beta 50-C-ZRS	GX1	12	169	22
Beta 60-ZSS	GX2	22	201	27
Beta 60-SSS	GX2		281	22
Beta 60-SGV	GX2		281	22
Beta 70-C-ZRS-ZSS	GX2	31	211	27
Beta 70-C-SRS-SSS	GX2		281	27
Beta 80-ZRS-ZSS	GX2	47	231	27
Beta 80-SRS-SSS	GX2		325	36
Beta 80-C-ZRS-ZSS	GX4	74	241	36
Beta 100-ZRS-ZSS	GX4	89	261	36
Beta 100-D-ZSS	GX4	38	261	36
Beta 100-D-SSS	GX4		331	36
Beta 110-ZRS-ZSS	GX4 / GX8*	191	293 / 323	46
Beta 110-SRS-SSS	GX4		331	36
Beta 120-ZRS-ZSS	GX4 / GX8*	153	303 / 333	46
Beta 120-C-ZSS	GX4 / GX8*	229	303 / 333	46
Beta 120-C-SSS	GX4		395	46
Beta 140-ZRS-ZSS	GX4 / GX8*	140	323 / 353	46
Beta 140-SRS-SSS	GX4		331	36
Beta 140-C-ZSS	GX4 / GX8*	140	323 / 353	46
Beta 140-C-SSS	GX4		331	36
Beta 165-ZSS	GX16	700	398	55
Beta 165(-C)-SGV / -SSF	GX8		435	46
Beta 165-SSS	GX8		435	46
Beta 180-ZSS	GX8 / GX16*	306	393 / 413	55
Beta 180-SSS	GX8		435	46
Beta 180-C-ZSS	GX8 / GX16*	370	393 / 413	55
Beta 180-C-SSS	GX8		435	46

Linear Drive	Size	Moment max. [Nm]	AA min.	SW
Gamma 90-ZSS	GX4	77	241	36
Gamma 90-ZSSD	GX2	37	235	36
Gamma 120-ZSS	GX4	90	261	36
Gamma 120-ZSSD	GX4	57	264	36
Gamma 160-ZSS	GX4 / GX8*	153	303 / 333	46
Gamma 160-ZSSD	GX4	74	305	46
Gamma 220-ZSS	GX8 / GX16*	306	393 / 413	55
Gamma 220-ZSSD	GX4 / GX8*	107	325 / 377	46
Gamma 280-ZSS	GX16	450	398	55
Gamma 280-ZSSD	GX8 / GX16*	300	393 / 409	50
Sigma 70-ZRS	GX2	22	201	27
Sigma 90-ZRS	GX2	36	211	27
Sigma 90-ZRSD	GX2	18	217	27
Sigma 120-ZRS	GX4	89	246	36
Sigma 120-ZRSD	GX4	57	264	36
Sigma 160-ZRS	GX4 / GX8*	153	303 / 333	46
Sigma 160-ZRSD	GX4	77	303 / 333	46

Size	D1	D2		L1	L2
		St	VA		
GX1	57	30x2	30x2.0	20	24
GX2	88	40x2,5	40x2.5	20	24
GX4	100	45x2,5	44,5x1.5	25	28
GX8	125	60x2,5	60,3x1.6	30	32
GX16	155	70x1,5	70,0x2.0	50	35

* The larger version is to be selected where necessary.

This table is a selection. More sizes and combinations on request.

Pillow bearing drawing

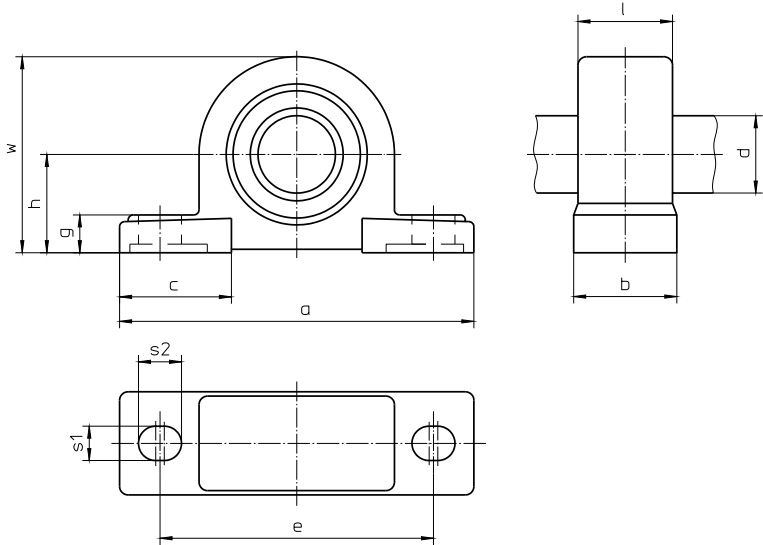

For Joint shaft	a	b	c	d	e	g	h	l	s1	s2	w	Weight GX-shaft in kg			
												Length 500 mm complete		100 mm tube	
												St	VA	St	VA
GX1	167	48	54	30	127	19	47,6	43	17	21	92	1.20	1.21	0.14	0.14
GX2	190	54	60	40	146	20	54	50	17	22	106	2.37	2.42	0.23	0.23
GX4	206	60	65	45	159	22	57,2	55	20	25	114	3.56	3.11	0.26	0.16
GX8	265	70	77	60	203	27	76,2	65	25	29	150	6.08	5.55	0.35	0.23
GX16	292	78	85	70	232	30	88,9	64	25	31	175	11.03	11.37	0.26	0.34

Joint shaft diagram

Depends on length and revolution

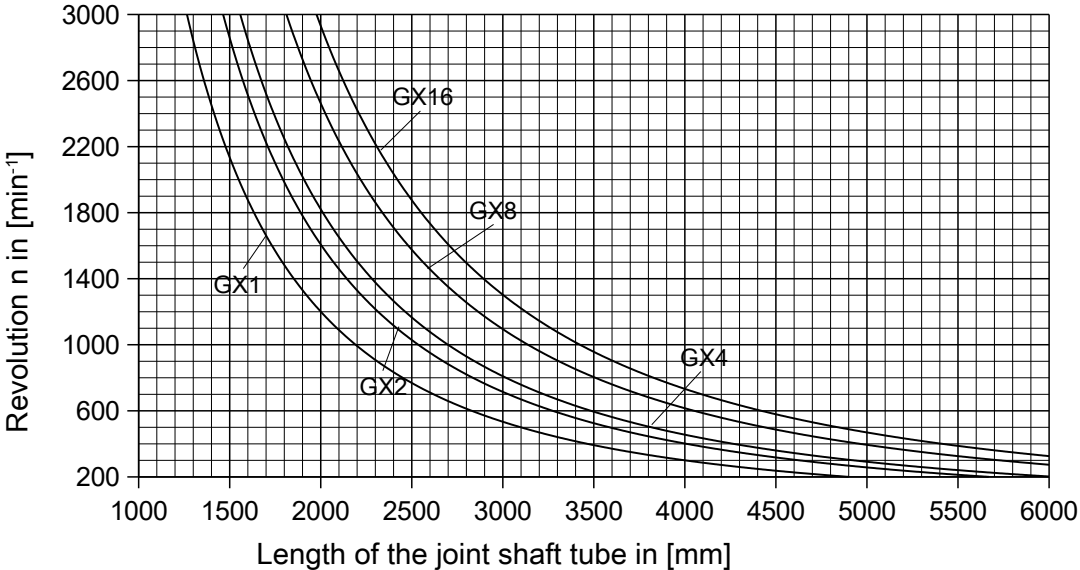

Motor mounting, coupling (MGK)

Standard motor mounting (3-part)

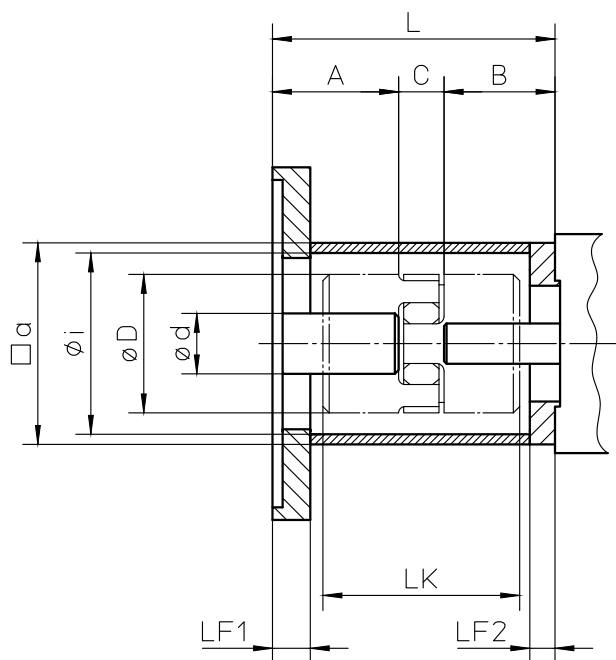

Gr.	α	ϕ_i	LF1	LF2
55	55	46	15	8
80	80	69	15	10
110	110	88	20	15

$$L = A + B + C$$

- A = Length of drive shaft of motor/gear
- B = Length of drive journal of mechanical linear drive
- C = See Table for Coupling Sizes

Size of coupling

	9	12	14	19	24	28
C	10	12	13	16	18	20
ϕd_{max}	11	12	16 (14)	20	28	38
ϕD	20	25	30	40	55	65
LK	30	34	35 (50)	66	78	90

Clamping hub and clamping ring (from size 14) possible.
Dimensions in brackets apply for clamping ring.

Chapter X

Custom Designs

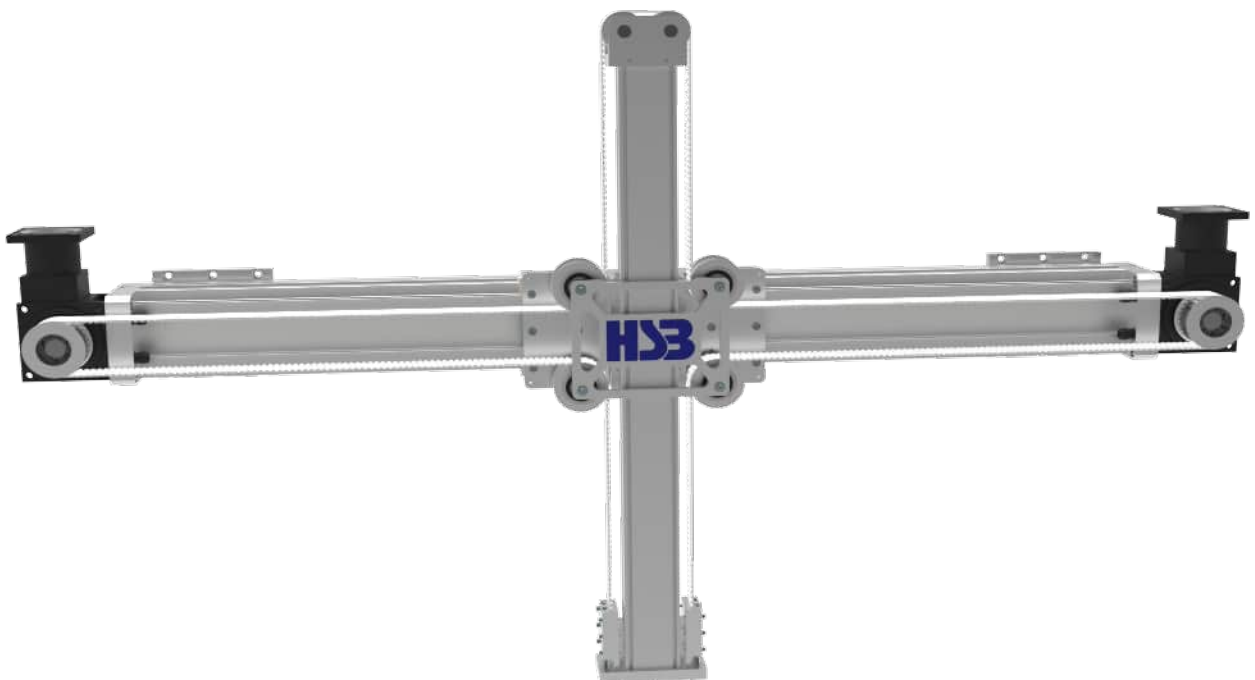

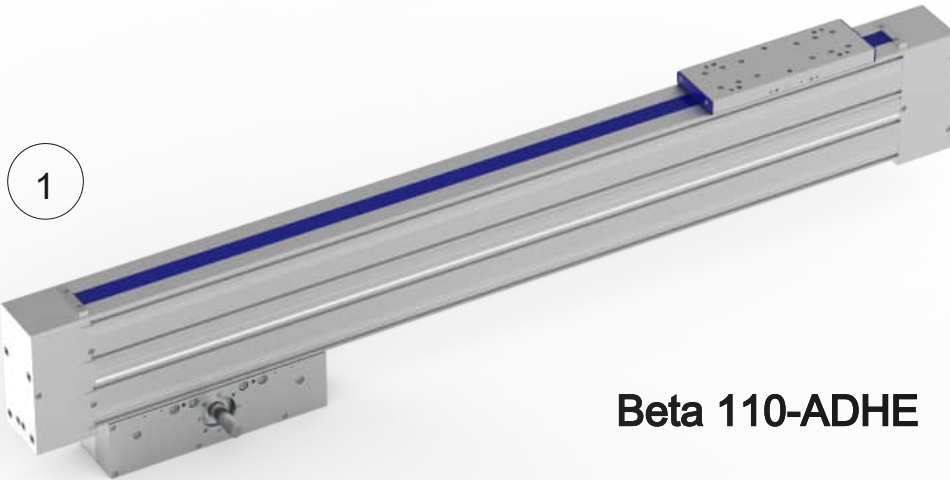

Beta 110-ADHE

The ADHE design (driven carriage, duplex unit) is currently available in sizes 50 and 110 but can in principle be supplied in the HSB-beta® series sizes.

The lower carriage with the gearbox/motor detects that the profile tube and the top carriage are travelling. There is therefore a relative/ double stroke action. An outrigger can be attached to the upper carriage and thereby e.g. a spray lance with a single profile length of the linear unit can be immersed into a tool by the doubled stroke.

The upper linear unit with the single carriage is enclosed by the covering strip.



Beta 100-D-ASS Rotator

The HSB-beta®-ARS-ASS versions are often used with a vertical axis.

The carriage and drive are upright and the profile tube runs vertically.

The gripper/attachments often also need to rotate.

This can be implemented very simply with the HSB rotator.

A top and bottom-mounted tube is fed through the rear cavity of the profile.

A servo motor is attached at the top by a timing belt drive (or motor mounting)

while the gripper or attachment can be attached to the adapter plate on the bottom.

HSB-beta®

3

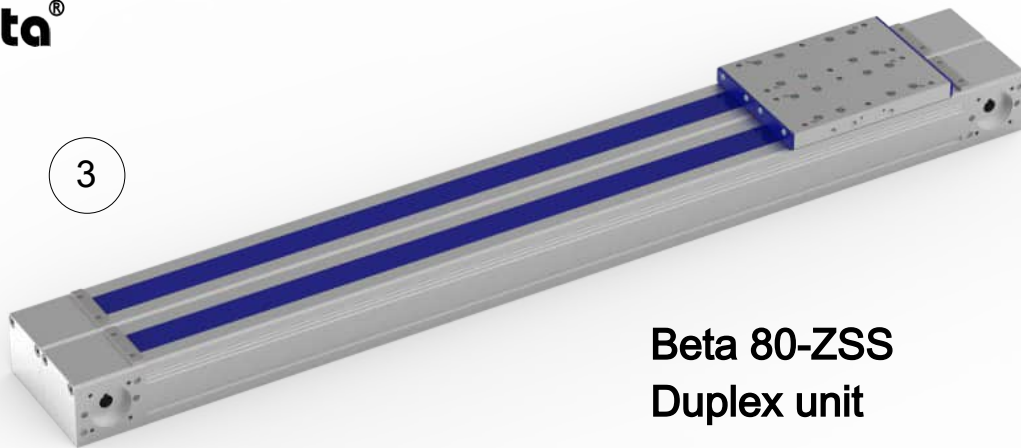
**Beta 80-ZSS
Duplex unit**

4

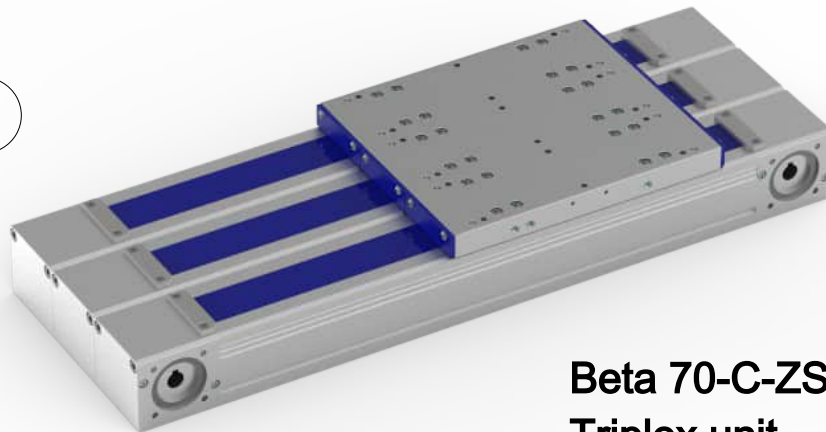
**Beta 70-C-ZSS
Triplex unit**

With a spindle or toothed belt drive, all HSB-beta® series sizes can be converted into duplex/triplex or multiple units.

Profiles are screwed/glued together. The result is a broad, flat linear unit. A shared carriage plate allows large torques to be accommodated in the M_x direction. With a shared drive (toothed belt units) it is possible to generate greater thrust forces.

Counter-acting movements can be implemented with single carriage plates.

If different spindle pitches are used it is possible to realise different speeds from the same engine speed.

HSB-delta®

5

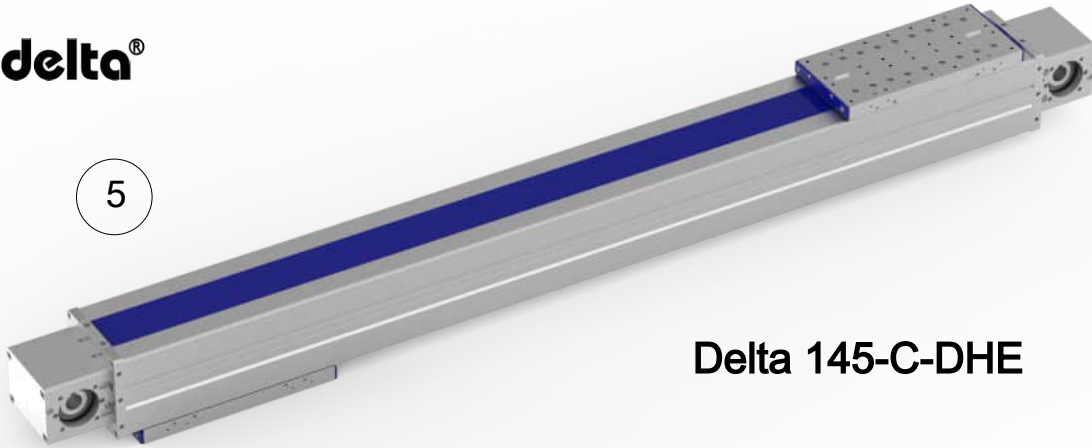

Delta 145-C-DHE

The DHE (double stroke unit) is currently available for the 145 size but other HSB-delta® series sizes are possible in principle.

In this case, along with the flat design and large transferable torques, an optimum ratio of stroke to overall length was required due to the duplex design of the HSB-delta® series.

HSB-kappa®

6

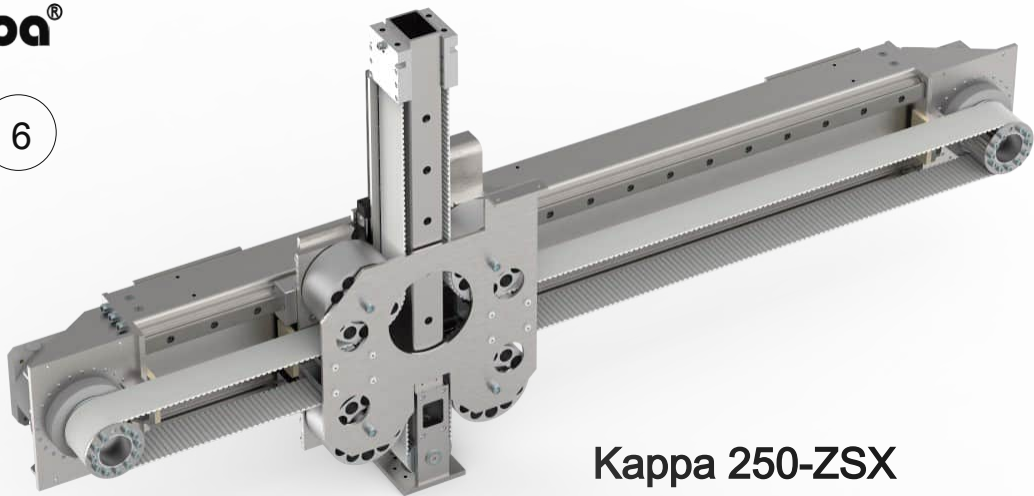

Kappa 250-ZSX

The linear units of the HSB-kappa® series are a particular highlight of HSB Automation GmbH.

The function principle is well known and some of our competitors supply and build this concept as a small system. The challenge for HSB Automation GmbH lay not in the system itself but in the parameters to be achieved:

it needed to move a mass of up to 100 kg horizontally by 2000 mm and vertically by 600 mm with 30 strokes/ minute. All components had to be non-rusting since it was for the food industry.

To save mass and weight in the vertical axis conventional linear units were out of the question. The drive which had to be co-transported (gearbox and servomotor with brake) overstressed every system. We therefore opted for the system with two vertical motors and a toothed belt.

Chapter TL

Technology

Linear

Linear Tables

HSB-alpha®

Mechanical Linear Drive

HSB-beta®

Compact Module

HSB-delta®

Portal Linear Drive

HSB-gamma®

Portal Linear Drive

HSB-sigma®

Examples of multi-axis systems

Type **HB-beta**[®]

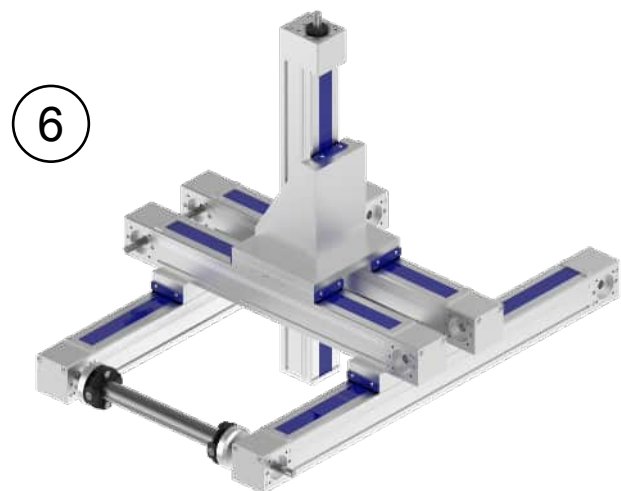
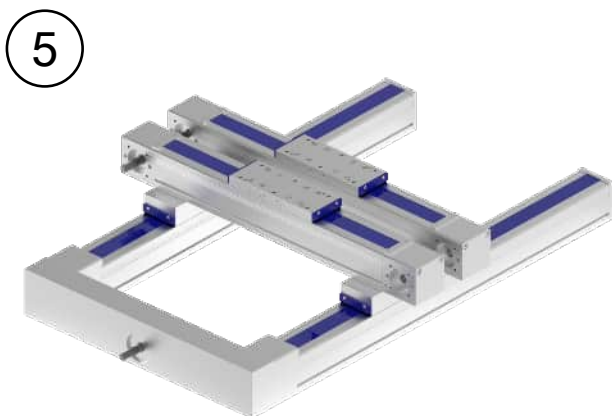
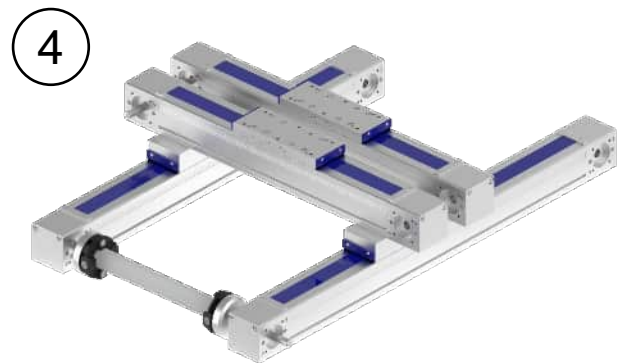
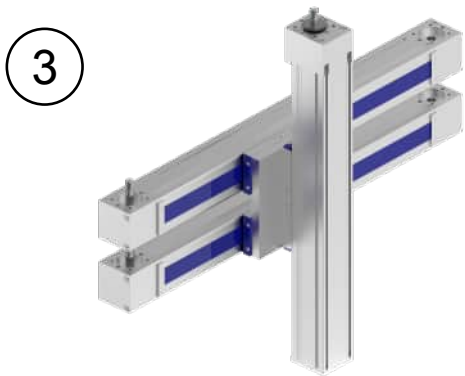

Types **HB-delta**[®] and **HB-alpha**[®]

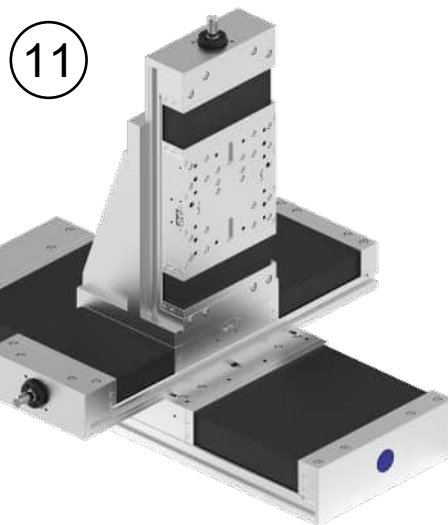
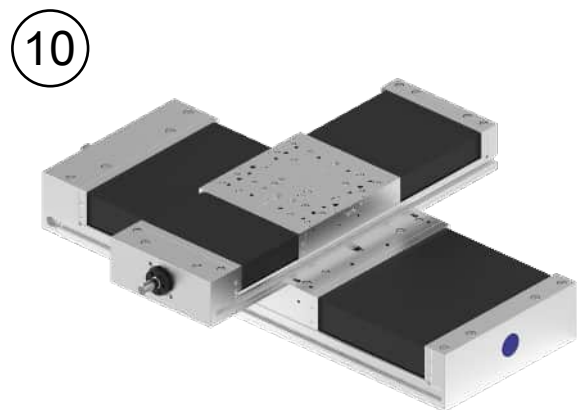
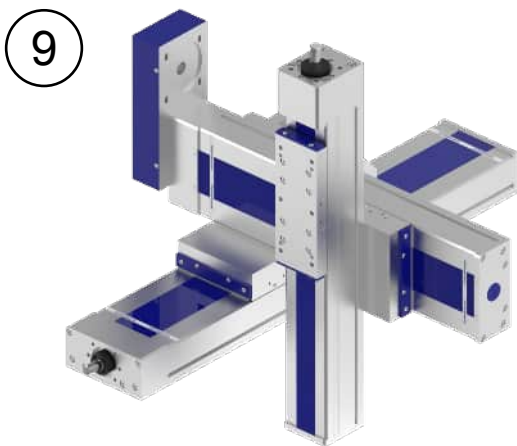
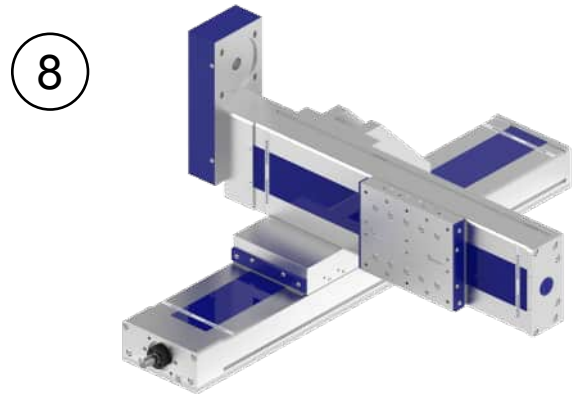
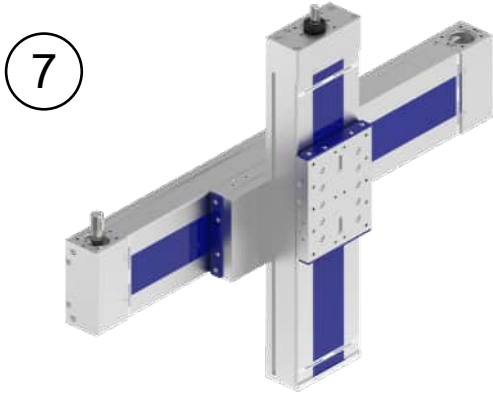

Mechanical Linear Drives

HB-beta®

with spindle drive or toothed belt drive
with rail guide or roller guide

Compact Modules

HB-delta®

with spindle drive or toothed belt drive
with rail guide

Linear Tables

HB-alpha®

with spindle drive
with rail guide

Portal Linear Drive

HB-gamma®

with rack-and-pinion drive or toothed belt drive
with rail guide

Portal Linear Drive

HB-sigma®

with toothed belt drive
with roller guide

Customised solutions

In accordance with customer requirements (e.g.: ex-protection according to Atex, corrosion-resistant, clean room compatible, toothed belt linear drive right/left, etc.) .

Handling systems

For the most varied of industries

Accessories

Fixing parts, proximity switches, gears, motor mountings, couplings, belt drives with various gear ratios

Selection criteria for the guide system

Roller guide

Smooth travel thanks to optimum rolling characteristics
Low noise thanks to quiet rolling
High moment acceptance thanks to optimum load transmission into profile
Large stroke lengths possible without a problem
Low maintenance due to long-life lubrication of rollers
Low-cost alternative to rail guide

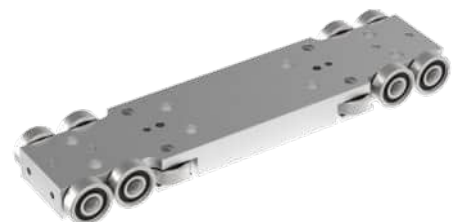

Rail guide

High load capacity of guide
Longer service life
High level of guiding accuracy

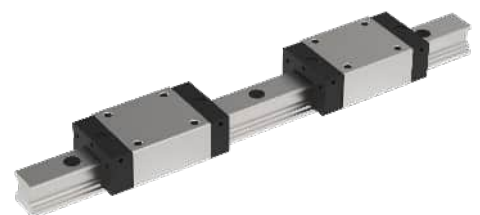

Further information regarding the performance overview

All specifications refer to the standard configuration. The values given for special designs may deviate considerably. The loads specified are the maximum single loads possible for the entire system. If there are different loads (several different forces or moments), the single permissible loads are lower. There may be elastic deformations which will influence the level of accuracy. For mechanical linear drives with roller guides, the static load rating (C_{stat}) applies for static loads.

Repeat accuracy is defined as the ability of the mechanical linear drive to once again return to the same actual position under the same conditions. Conditions such as temperature, load, speed, deceleration and direction of travel may influence the repeat accuracy.

Mechanical Linear Drives with Screw Drive

For calculating service life, the guide and screw drive load ratings are used. Please contact us for further information. The idle torques refer to the respective standard configurations (not double nut or low-backlash single nut) and are measured at a very low speed ($\approx 0 \text{ min}^{-1}$). Production and assembly tolerances vary by $\pm 20 \%$.

The permissible deflection of the linear axis is 0.2 mm/m (1 mm maximum).

For special applications trapezoidal screw drives optional stand for disposal. When used, please ask our technical sales specialists and clarify the exact use.

Mechanical Linear Drives with Toothed Belt Drive

For calculating service life, the guide load ratings are used. Please contact us for further information.

The idle torques refer to the respective standard configurations and are measured at a very low speed ($\approx 0 \text{ min}^{-1}$). Production and assembly tolerances vary by $\pm 20\%$.

The specification for load F_x is the maximum value permitted for low speeds. Please contact us for the maximum value at higher speeds.

The permissible deflection of the linear axis is 0.5 mm/m (2.5 mm maximum).

It is generally recommended to change the toothed belt after 5 to 7 years, as the base material (PU) ages. A theoretical service life calculation is not possible.

Running performance and noise

Contingent on the production tolerances in the used components (e.g. screw or toothed belt drive, guide, mounting, etc.), the running behaviour and noise development for linear drives and linear tables can vary enormously even with the same units. Using customised solutions, such as for example longer spindle supports or damping, the running behaviour can be changed for the better.

Straightness and torsion

All aluminium profiles used for the linear devices and the linear tables are extruded profiles.

The straightness and torsion of these profiles may deviate as a result of the manufacturing process.

The permissible deviations in accordance with DIN 17615 are, however, generally far from exceeded.

However, it may be necessary to align the linear drives using suitable levelling elements or

fix them to a mounting surface machined with sufficient accuracy in order to achieve the desired guiding accuracy.

Better tolerances of 0.1 mm / 1000 mm can thus be achieved.

Stroke length

The stroke length specified in the ordering code refers to the maximum permissible stroke.

Acceleration-, braking distances or possible overrun must be taken into consideration here.

We reserve the right to make technical changes to all products!

Drive Dimensions for Mechanical Linear Drives

with screw drive or toothed belt drive

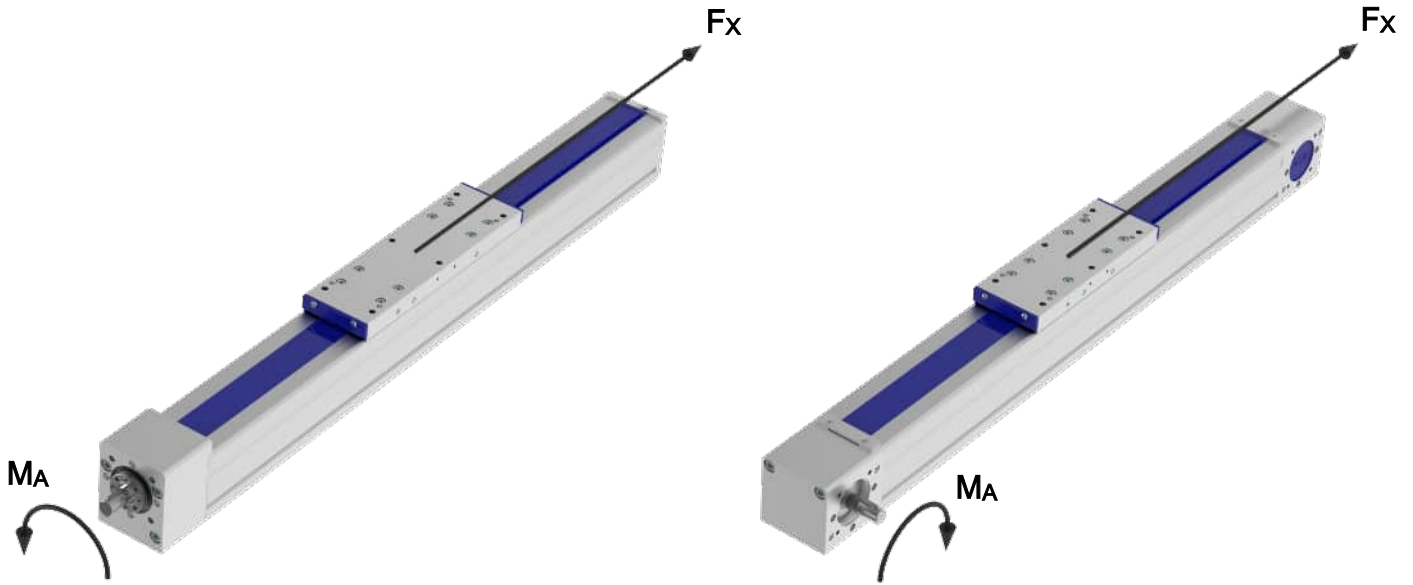

Required drive torque* M_A [Nm]:

$$M_A = M_{load} + M_{idle}$$

Definitions:

- M_A : Required drive torque [Nm]
 M_{load} : Load torque [Nm]
 M_{idle} : See data sheets [Nm]
 F_x : Feed force in horizontal application [N]
 Feed force in vertical application [N]

$$M_{load} = \frac{F_x \cdot p}{2 \cdot \pi \cdot 1000}$$

$$F_x = m \cdot g \cdot \mu + m \cdot a$$

$$F_x = m \cdot (g + a)$$

- | | | |
|---------|---|--------------------------|
| μ : | Friction coefficient for linear guide | $\mu = 0.006$ |
| | Friction coefficient for roller guide | $\mu = 0.002$ |
| | Friction coefficient for sliding guide | $\mu = 0.1$ |
| g : | Gravitational acceleration [m/s ²] | $g = 9.81 \text{ m/s}^2$ |
| a : | Acceleration [m/s ²] | |
| m : | Transport weight [kg] | |
| p : | Spindle pitch [mm] (screw drive) or stroke per revolution [mm] (toothed belt drive) | |

* (rough estimate)

Basics for Calculating the Forces and Moments

Forces (**F**) result if

a mass (**m**) being accelerated (**a**).

a mass (**m**) being accelerated due to gravity (**a**).

This means:

$$\mathbf{F_x , F_y = m \cdot a}$$

$$\mathbf{F_z = m \cdot (g + a)}$$

(vertical applications)

A moment is caused by a force (**F**) acting upon a lever arm (**l**).

This means a force is acting off-centre.

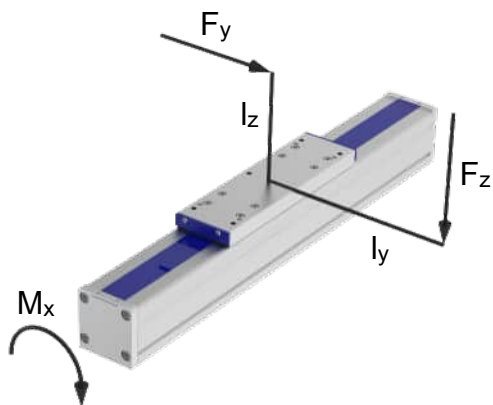

$$\mathbf{M_x = F_y \cdot l_z \text{ oder } F_z \cdot l_y}$$

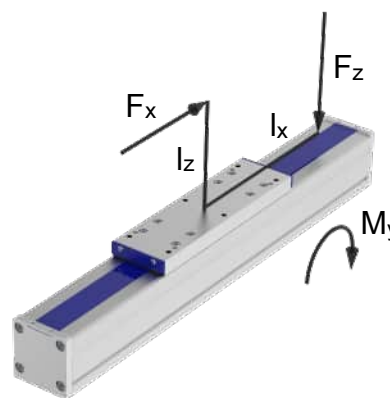

$$\mathbf{M_y = F_x \cdot l_z}$$

$$\mathbf{M_y = F_z \cdot l_x}$$

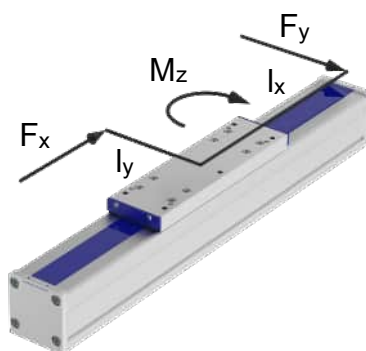

$$\mathbf{M_z = F_x \cdot l_y}$$

$$\mathbf{M_z = F_y \cdot l_x}$$

In most of the applications, there are combinations of these forces.

The resulting end forces must always be smaller than the permitted values.

For calculating service life, the actual forces are used.

(See following pages)

Forces at the roller guide

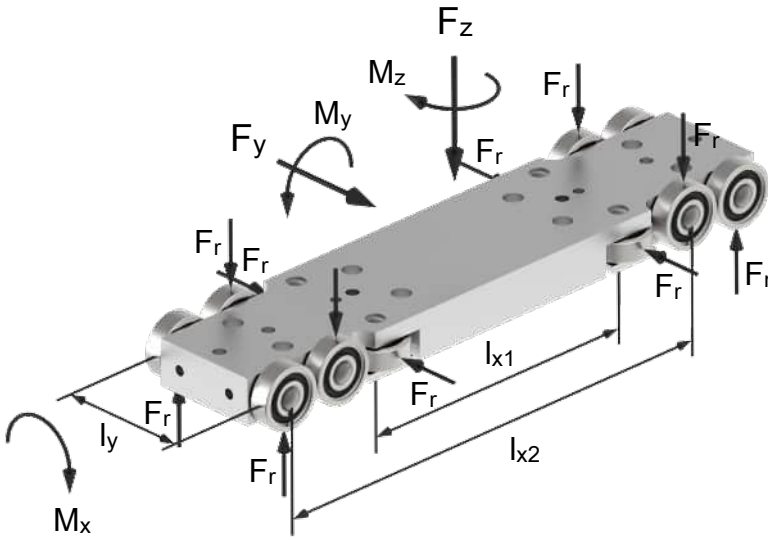

- F_x : Force in feed direction
- F_y : Force in Y direction
- F_z : Force in Z direction
- M_x : Moment for longitudinal axis (X)
- M_y : Moment for lateral axis (Y)
- M_z : Moment for vertical axis (Z)
- F_r : Force on the roller
- l_y : Guiding distance in y direction (see Table on page TL11)
- l_{x1} : Guiding distance in x direction (see Table on page TL11)
- l_{x2} : Guiding distance in x direction (see Table on page TL11)

Direction of force F_y

F_y shared by 2 rollers

$$F_r = F_y \cdot 0.5$$

Direction of force F_z

+ F_z and - F_z shared by 4 rollers

$$F_r = F_z \cdot 0.25$$

Moment M_x

M_x shared by 2 rollers

$$F_r = M_x / l_y \cdot 0.5$$

Moment M_y

M_y shared by 2 rollers

$$F_r = M_y / l_{x2} \cdot 0.5$$

Moment M_z

M_z shared by 1 roller

$$F_r = M_z / l_{x1} \cdot 1$$

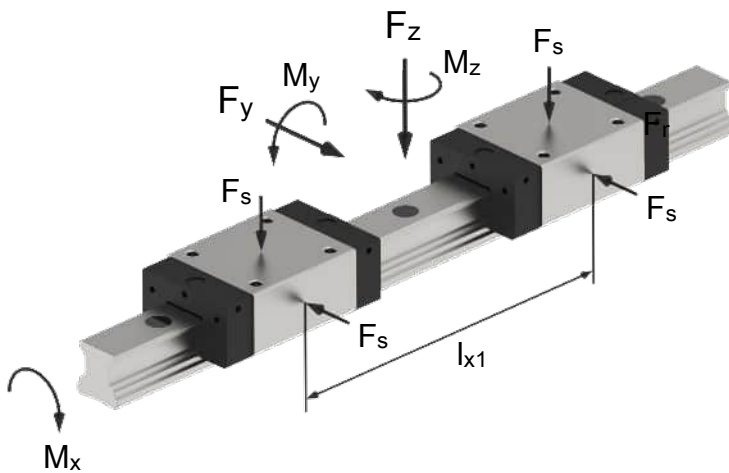

- F_x** : Force in feed direction
- F_y** : Force in Y direction
- F_z** : Force in Z direction
- M_x** : Moment for longitudinal axis (X)
- M_y** : Moment for lateral axis (Y)
- M_z** : Moment for vertical axis (Z)
- M_t** : Permissible dynamic moment for the guide carriage
(see Table on page TL12)
- C** : Dynamic load rating (**C_{dyn}**) for the guide carriage
(see Table on page TL12)
- F_s** : Force on a carriage
- l_{x1}** : Guiding distance in x direction
(see Table on page TL12)

Direction of force F_y

F_y shared by 2 carriages

$$F_s = F_y \cdot 0.5$$

Direction of force F_z

F_z shared by 2 carriages

$$F_s = F_z \cdot 0.5$$

Moment M_x

M_x shared by 2 carriages
With combined external load (F_z and F_y)
in combination with a torsional moment

$$F_s = |F_z| + |F_y| + C \cdot (|M_x| / M_t) \cdot 0.5$$

Moment M_y

M_y shared by 2 carriages
(with opposite direction of force)

$$F_s = M_y / l_{x1} \cdot 1$$

Moment M_z

M_z shared by 2 carriages
(with opposite direction of force)

$$F_s = M_z / l_{x1} \cdot 1$$

Forces at the double rail guide

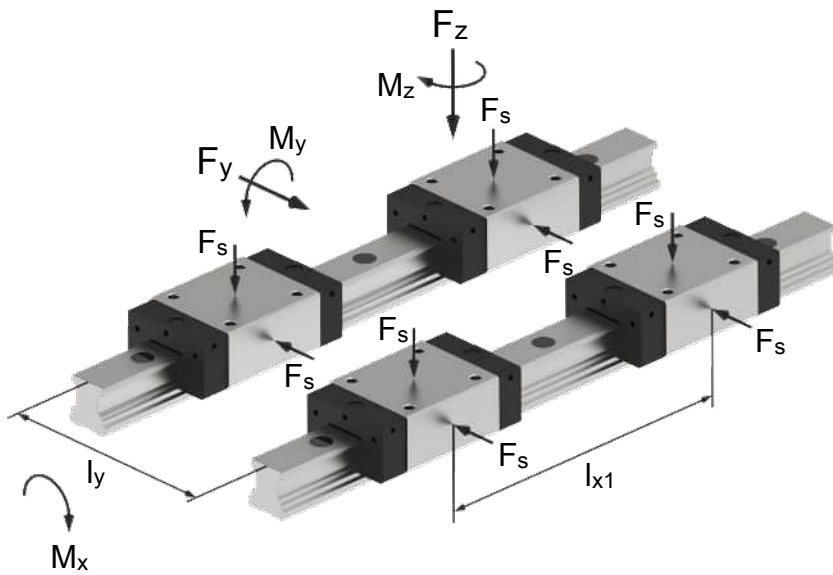

- F_x : Force in feed direction
- F_y : Force in Y direction
- F_z : Force in Z direction
- M_x : Moment for longitudinal axis (X)
- M_y : Moment for lateral axis (Y)
- M_z : Moment for vertical axis (Z)
- F_s : Force on a carriage
- l_y : Guiding distance in y direction (see Table on page TL12)
- l_{x1} : Guiding distance in x direction (see Table on page TL12)

Direction of force F_y

F_y shared by 4 carriages

$$F_s = F_y \cdot 0.25$$

Direction of force F_z

F_z shared by 4 carriages

$$F_s = F_z \cdot 0.25$$

Moment M_x

M_x shared by 4 carriages
(2 per opposite direction of force)

$$F_s = M_x / l_y \cdot 0.5$$

Moment M_y

M_y shared by 4 carriages
(2 per opposite direction of force)

$$F_s = M_y / l_{x1} \cdot 0.5$$

Moment M_z

M_z shared by 4 carriages
(2 per opposite direction of force)

$$F_s = M_z / l_{x1} \cdot 0.5$$

Service Life of Roller, Rail Guide and Ball Screw

It is primarily the guide values for the mechanical linear drive that are used when calculating nominal service life. The ball screw must also be taken into consideration for the drive with ball screw spindle. With the multitude of parameters crucial for the service life of the entire mechanical linear drive (forces and moments, taking into consideration directions and possible combinations, lead to a moderate load (F_m); ambient conditions, duty cycle...), the following simplified formulae only serve as an initial estimate.

1. Moderate load of the guide or ball screw

$$F_m = (F_1^3 \cdot q_1 / 100 + F_2^3 \cdot q_2 / 100 + F_n^3 \cdot q_n / 100)^{1/3}$$

2. Nominal service life of the roller guide

$$L = (C / F)^3 \cdot 10^5 \cdot R$$

$$F = F_m + F_v$$

3. Nominal service life of the sliding guide

$$L = (C / F)^3 \cdot 10^5$$

$$F = F_m + F_v$$

4. Nominal service life of the ball screw

$$L_{KGT} = (C_{KGT} / F)^3 \cdot 10^6$$

$$F = F_m + F_v \text{ (} F_v \text{ only with double nut (MM); approx. 10 \%)}$$

Definitions

F_m : Moderate load [N] of guide or ball screw

F_1, F_2, F_n : Stepped single load [N]

q_1, q_2, q_n : Stroke rate for F_1, F_2, F_n [%]

L : Nominal service life of guide [m]

C : Dynamic load rating of guide (C_{dyn}) [N] (see Table on pages TL11 and TL12)

R : Factor for roller guide size

Beta 50 ... Beta 80 + Sigma 70: $R = 0,625$; Beta 80-C + Sigma 90: $R = 0,75$;

Beta 100 + 110 + Sigma 120: $R = 0,87$;

Beta 120 + 140 + Sigma 160: $R = 1,1$;

Delta 90: $R = 0,595$ (Y) und $R = 0,625$ (Z)

F : Equivalent load [N] for guide or ball screw

F_v : Pretensioning [N] (3 % of C_{dyn} , 5 % for roller guide (see Table on pages TL11 and TL12)

L_{KGT} : Nominal service life of the ball screw [revolutions]

C_{KGT} : Dynamic load rating of the ball screw (C_{dyn}) [N] (see Table on page TL13)

Technical Data for Mounted Guides

Static and dynamic load ratings of the roller guides

Unit size	Size (∅) [mm]	Number of supporting rollers for Fz	Number of supporting rollers for Fy	Load rating per roller C _{stat} [N]	Load rating per roller C _{dyn} [N]	Guide distance* in direction x [mm]		Guide distance in direction y [mm]
						lx1	lx2	ly
Beta 50-C	20	4	2	850	1500	86 (136)	86 (136)	30.5
Beta 50-C-ARS						82	81	
Beta 70-C	20	4	2	850	1500	74 (124)	138.5 (188.5)	41.5
Beta 70-C-ARS						120	182	
Beta 80	20	4	2	850	1500	95 (155)	156.5 (216.5)	42.5
Beta 80-ARS						155	216.5	
Beta 80-C	24	4	-	1240	2750	-	148.5 (208.5)	42.4
		-	2	2300	4200	75 (135)	-	-
Beta 80-C-ARS	24	4	-	1240	2750	-	208.5	42.4
		-	2	2300	4200	135	-	-
Beta 100	28	4	2	1850	3200	136 (256)	223 (343)	47
Beta 110	28	4	2	1850	3200	175 (355)	262 (442)	66
Beta 110-ARS						253	340	
Beta 120	35	4	2	2590	5280	148 (328)	148 (328)	70
Beta 140	35	4	2	2590	5280	202 (382)	202 (382)	98
Beta 140-ARS						192 (272)	192 (272)	
Delta 90	20	4	-	790	1830	-	100 (180)	54.4
	19	-	2	1370	2700	100 (180)	-	-
Sigma 70	20	4	4	850	1500	67 (117)	71 (121.5)	57
Sigma 90	24	4	4	1240	2750	76 (126)	99 (149)	77
Sigma 120	28	4	4	1850	3200	130 (260)	160.5 (290)	99
Sigma 160	35	4	4	2590	5280	145 (295)	177.5 (327.5)	135

The pretensioning per roller is approx. 5 %.

* () = Data for long entire carriage, Beta ARS and Sigma ARH

Dynamic load ratings of the rail guides (THK and Rex = Rexroth)

Unit size	Size	Number of rails	Number of guiding carriages per carriage	Load rating per carriage C _{dyn} [N] THK / Rex	Pretensioning F _v [N] THK / Rex	M _t [Nm] THK / Rex	Guide distance* in direction x [mm]		Guide distance in direction y [mm]
							lx1	ly	
Beta 40	12	1	2	3175 / 2310	-	18,3 / 13,7	83 (163)	-	
Beta 60-ZSS	15	1	2	11270 / 9860	564 / 620	127 / 95	102 (152)	-	
Beta 60-SSS	15	1	2	11270 / 9860	564 / 620	127 / 95	118 (168)	-	
Beta 70-C-ZSS	15	1	2	11270 / 9860	564 / 620	127 / 95	120 (170)	-	
Beta 70-C-SSS	15	1	2	11270 / 9860	564 / 620	127 / 95	124 (174)	-	
Beta 70-C-ASS	15	1	2	11270 / 9860	564 / 620	127 / 95	164	-	
Beta 80-ZSS	20	1	2	17700 / 23400	885 / 1500	286 / 300	131 (191)	-	
Beta 80-SSS	20	1	2	17700 / 23400	885 / 1500	286 / 300	128 (188)	-	
Beta 80-C	25	1	2	25160 / 28600	1258 / 1820	447 / 410	122 (182)	-	
Beta 80-C-ASS	25	1	2	25160 / 28600	1258 / 1820	447 / 410	172	-	
Beta 100	20	1	2	17700 / 23400	885 / 1500	286 / 300	152 (272)	-	
Beta 100-D-ZSS	15	2	4	11270 / 9860	564 / 620	-	150 (210)	56	
Beta 100-D-ASS	15	2	4	11270 / 9860	564 / 620	-	192	56	
Beta 100-D-SSS	15	2	4	11270 / 9860	564 / 620	-	141 (201)	56	

Technical Data for Mounted Guides

Dynamic load ratings of the rail guides (THK and Rex = Rexroth)

Unit size	Size	Number of rails	Number of guiding carriages per carriage	Load rating per carriage C_{dyn} [N] THK / Rex	Pretensioning F_v [N] THK / Rex	M_t [Nm] THK / Rex	Guide distance* in	
							direction x [mm] lx1	direction y [mm] ly
Beta 110	25	1	2	25160 / 28600	1258 / 1820	447 / 410	203 (383)	-
Beta 110-ASS	25	1	2	25160 / 28600	1258 / 1820	447 / 410	315	-
Beta 120-ZSS	25	1	2	25160 / 28600	1258 / 1820	447 / 410	142 (322)	-
Beta 120-C	30	1	2	35557 / 36500	1778 / 2540	686 / 630	184 (364)	-
Beta 140	15	2	4	11270 / 9860	564 / 620	-	180 (360)	72
Beta 140-ASS	15	2	4	11270 / 9860	564 / 620	-	242 (322)	72
Beta 140-C-ZSS	20	2	4	17700 / 23400	885 / 1500	-	220 (400)	76
Beta 140-C-ASS	20	2	4	17700 / 23400	885 / 1500	-	220 (300)	76
Beta 140-C-SSS	20	2	4	17700 / 23400	885 / 1500	-	210 (390)	76
Beta 165-ZSS	35	1	2	49447 / 51800	2472 / 3350	1214 / 1010	198 (398)	-
Beta 165-SSS	35	1	2	49447 / 51800	2472 / 3350	1214 / 1010	228 (428)	-
Beta 165-C-SSF	30L	2	4	43018 / 46000	2151 / 3200	-	280	128
Beta 180-ZSS	20	2	4	17700 / 23400	885 / 1500	-	176 (396)	84
Beta 180-ASS	20	2	4	17700 / 23400	885 / 1500	-	310	84
Beta 180-SSS	20	2	4	17700 / 23400	885 / 1500	-	233 (453)	84
Beta 180-C-ZSS	25	2	4	25160 / 28600	1258 / 1820	-	272 (492)	84
Beta 180-C-ASS	25	2	4	25160 / 28600	1258 / 1820	-	307	84
Beta 180-C-SSS	25	2	4	25160 / 28600	1258 / 1820	-	233 (453)	84
Delta 110-C	15	2	4	11270 / 9860	564 / 620	-	75 (195)	66
Delta 145-C	20	2	4	17700 / 23400	885 / 1500	-	87 (207)	87
Delta 200	25	2	4	25160 / 28600	1258 / 1820	-	144 (294)	126
Delta 240(-C)	25	2	4	25160 / 28600	1258 / 1820	-	159 (279)	150
Alpha 15B	15	2	4	11270 / 9860	564 / 620	-	94 (164)	105
Alpha 20B	20	2	4	17700 / 23400	885 / 1500	-	143 (243)	160
Alpha 30B	30	2	4	35557 / 36500	1778 / 2540	-	205 (335)	240
Alpha 35B	35L	2	4	57860 / 66700	2893 / 4450	-	286 (436)	336
Gamma 90-ZSS	15	2	4	11270 / 9860	564 / 620	-	135 (285)	73
Gamma 90-ZSSD	15	2	4	11270 / 9860	564 / 620	-	75	73
Gamma 90-ASH	15	2	4	11270 / 9860	564 / 620	-	265	73
Gamma 90-AZS.	15	2	4	11270 / 9860	564 / 620	-	255	90
Gamma 120-ZSS	20	2	4	17700 / 23400	885 / 1500	-	170 (320)	90
Gamma 120-ZSSD	20	2	4	17700 / 23400	885 / 1500	-	80	104
Gamma 120-ASH	20	2	4	17700 / 23400	885 / 1500	-	320	90
Gamma 120-AZS.	20	2	4	17700 / 23400	885 / 1500	-	320	115
Gamma 160-ZSS	25	2	4	25160 / 28600	1258 / 1820	-	208 (408)	120
Gamma 160-ZSSD	25	2	4	25160 / 28600	1258 / 1820	-	208 (408)	120
Gamma 160-ASH	25	2	4	25160 / 28600	1258 / 1820	-	408	120
Gamma 160-AZS.	25	2	4	25160 / 28600	1258 / 1820	-	402	151
Gamma 220-ZSS	25L	2	4	29208 / 37300	1460 / 2430	-	210 (390)	180
Gamma 220-ZSSD	25L	2	4	29208 / 37300	1460 / 2430	-	210 (390)	180
Gamma 220-ASS	25L	2	4	29208 / 37300	1460 / 2430	-	390	180
Gamma 220-AZS.	25L	2	4	29208 / 37300	1460 / 2430	-	440	196
Gamma 280-ZSS	35	2	4	49447 / 51800	2472 / 3350	-	275 (475)	236
Gamma 280-ZSSD	35	2	4	49447 / 51800	2472 / 3350	-	275 (475)	236
Gamma 280-AZSS	35	2	4	49447 / 51800	2472 / 3350	-	480	253

Technical Data for Mounted Ball Screws

Dynamic load ratings for ball screw

Unit size		Nominal Ø [mm]	Pitch P [mm]	C _{dyn} RH [N]	C _{dyn} LH [N]
Beta 40 Beta 50-C	Delta 90	12	5	3800	1907
			10	4300	-
Beta 70-C	Delta 110-C	16	5	12800	14800
			10	14300	-
			20	8100	-
			40	8500	-
Beta 60 Beta 80 Beta 100-D	Delta 145-C	20	5	14600	21000
			10	13500	-
			20	11500	-
			50	12300	-
Beta 80-SGV Beta 110 Beta 140(-C)		25	5	16100	19100
			10	15100	-
			25	15800	-
			50	14500	-
Beta 110-C-SGV Beta 120-C Beta 180(-C)	Delta 200 Delta 240(-C)	32	5	26200	25900
			10	33100	-
			20	30200	-
			40	15200	-
			60	18400	-
Beta 110-C-SGV Beta 165		40	5	34900	34900
			10	60000	60000
			20	45500	-
			40	44400	-
Beta 165-C-SGV		50	10	95600	-
			20	57500	-
Beta 165-C-SSF		50	10	95600	-
			20	116500	-
Alpha 15B		20	5	14600	17200
			10	13500	-
			20	11500	-
			50	12300	-
Alpha 20B		25	5	16100	19100
			10	15100	-
			25	15800	-
			50	14500	-
Alpha 30B		32	5	26200	25900
			10	33100	-
			20	30200	-
			40	15200	-
Alpha 35B		40	5	34900	34900
			10	60000	60000
			20	45500	-
			40	44400	-

(Dynamic load rating for ball screw nut in accordance with DIN 69051, 1989)

Maximum Drive Torques

Unit size	F _{Max} [N]	Stroke/revol. [mm]	M _{load} [Nm]	M _{idle} [Nm]	M _{total} [Nm]
Beta 40-Z..	500	100	7.96	0.30	8.26
Beta 40-S..	1000	10	1.59	0.40	1.99
Beta 50-C-ZRS	700	110	12.25	0.40	12.65
Beta 50-C-ARS	700	110	12.25	1.50	13.75
Beta 50-C-SRS	1000	10	1.59	0.30	1.89
Beta 60-ZSS	850	160	21.65	1.10	22.75
Beta 60-SGV-SSS	4000	50	31.83	0.70	32.53
Beta 70-C-Z..	1100	175	30.64	1.20	31.84
Beta 70-C-A..	900	220	31.51	1.00	32.51
Beta 70-C-S..	2000	40	12.73	0.40	13.13
Beta 80-Z..	1350	220	47.27	1.50	48.77
Beta 80-A..	1000	220	35.01	1.50	36.51
Beta 80-S..	4000	50	31.83	0.80	32.63
Beta 80-SGV	6000	50	47.75	1.00	48.75
Beta 80-C-Z..	2200	210	73.53	1.80	75.33
Beta 80-C-A..	1300	220	45.52	1.80	47.32
Beta 100-Z..	2800	200	89.13	2.50	91.63
Beta 100-D-ZSS	1500	160	38.20	5.00	43.20
Beta 100-D-ASS	2200	240	84.03	2.50	86.53
Beta 100-D-SSS	4000	50	31.83	1.30	33.13
Beta 110-Z..	4000	300	190.99	3.50	194.49
Beta 110-A..	2000	300	95.49	3.50	98.99
Beta 110-S..	6000	50	47.75	1.50	49.25
Beta 110-C-SGV (KGT 40xx)	16000	40	101.86	1.50	103.36
Beta 110-C-SGV (KGT 32xx)	12000	60	114.59	1.50	116.09
Beta 120-Z..	4000	240	152.79	3.20	155.99
Beta 120-C-ZSS	4800	300	229.18	4.50	233.68
Beta 120-C-SSS	12000	60	114.59	2.00	116.59
Beta 140-Z..	4000	220	140.06	3.50	143.56
Beta 140-A..	2500	240	95.49	3.50	98.99
Beta 140-S..	6000	50	47.75	1.50	49.25
Beta 140-C-ZSS	4000	220	140.06	3.50	143.56
Beta 140-C-ASS	2500	240	95.49	3.50	98.99
Beta 140-C-SSS	6000	50	47.75	1.50	49.25
Beta 165-ZSS	10000	450	716.20	12.00	728.20
Beta 165-SSS	18000	40	114.59	3.00	117.59
Beta 165-SGV	18000	40	114.59	3.00	117.59
Beta 165-C-SGV	25000	20	79.58	3.20	82.78
Beta 165-C-SSF	25000	20	79.58	3.20	82.78
Beta 180-ZSS	6000	320	305.58	8.00	313.58
Beta 180-ASS	3500	320	178.25	8.00	186.25
Beta 180-SSS	12000	60	114.59	2.50	117.09
Beta 180-C-ZSS	6000	320	305.58	8.00	313.58
Beta 180-C-ASS	3500	320	178.25	8.00	186.25
Beta 180-C-SSS	12000	60	114.59	2.50	117.09

Maximum Drive Torques

Unit size	F _{Max} [N]	Stroke/revol. [mm]	M _{load} [Nm]	M _{idle} [Nm]	M _{total} [Nm]
Delta 90-ZRS	800	100	12.73	2.00	14.73
Delta 90-SRS	1000	10	1.59	0.3	1.59
Delta 110-C-ZSS	950	110	16.63	2.00	18.63
Delta 110-C-SSS	2000	40	12.73	1.00	13.73
Delta 145-C-ZSS	2000	150	47.75	3.00	50.75
Delta 145-C-SSS	6000	50	47.75	1.00	48.75
Delta 200-ZSS	6000	220	210.08	6.8	216.88
Delta 200-SSS	10000	60	95.49	2.8	95.49
Delta 240-ZSS	2500	150	59.68	5.5	59.68
Delta 240-SSS	12000	60	114.59	2.8	114.59
Delta 240-C-ZSS	3800	180	108.86	5.5	108.86
Delta 240-C-SSS	12000	60	114.59	2.8	114.59
Alpha 15-B-155	4000	50	31.83	0.35	31.83
Alpha 20-B-255	6000	50	47.75	1.2	47.75
Alpha 30-B-325	12000	40	76.39	1.6	76.39
Alpha 35-B-455	18000	40	114.59	2.5	114.59
Gamma 90-ZSS	2300	210	76.87	3.2	76.87
Gamma 90-ZSSD	1150	200	36.61	2.9	36.61
Gamma 90-ASH	2300	210	76.87	3.2	76.87
Gamma 90-AZ.. (i=5:1)	1800	24	6.88	2.5	6.88
Gamma 120-ZSS	2800	200	89.13	3.00	92.13
Gamma 120-ZSSD	1800	200	57.30	3.00	60.30
Gamma 120-ASH	3200	240	122.23	3.6	122.23
Gamma 120-AZ.. (i=5:1)	2200	40	14.01	4.8	14.01
Gamma 160-ZSS	4000	240	152.79	4.00	156.79
Gamma 160-ZSSD	2200	210	73.53	4.00	77.53
Gamma 160-ASH	4000	240	152.79	4.00	156.79
Gamma 160-AZ.. (D75 i=5:1)	2200	40	14.01	5.8	14.01
Gamma 160-AZ.. (D90 i=5:1)	4000	40	25.46	5.8	25.46
Gamma 220-ZSS	6000	320	305.58	7.00	312.58
Gamma 220-ZSSD	2800	240	106.95	5.25	106.95
Gamma 220-ASS	6000	320	305.58	7.00	312.58
Gamma 220-AZ.. (M2 D90 i=5:1)	4000	40	25.46	7.2	25.46
Gamma 220-AZ.. (M2 D115 i=5:1)	6000	40	38.20	7.2	38.20
Gamma 220-AZ.. (M3 D90 i=5:1)	4000	40	25.46	7.2	25.46
Gamma 220-AZ.. (M3 D115 i=5:1)	7500	40	47.75	7.2	47.75
Gamma 280-ZSS	10000	450	716.20	11.00	727.20
Gamma 280-ZSSD	4000	300	190.99	11.00	201.99
Gamma 280-AZSS (D90 i=5:1)	4000	40	25.46	8.6	25.46
Gamma 280-AZSS (D115 i=5:1)	7500	40	47.75	8.6	47.75

Maximum Drive Torques

Unit size	F_{Max} [N]	Stroke/revol. [mm]	M_{load} [Nm]	M_{idle} [Nm]	M_{total} [Nm]
Sigma 70-ZRS	1050	125	20.89	0.85	21.74
Sigma 70-AR.	1050	125	20.89	0.85	21.74
Sigma 90-ZRS	1300	175	36.21	3.20	39.41
Sigma 90-ZRSD	650	175	18.10	3.20	21.30
Sigma 90-AR.	1300	150	31.04	2.30	33.34
Sigma 120-ZRS	2800	200	89.13	3.00	92.13
Sigma 120-ZRSD	1800	200	57.30	3.00	60.30
Sigma 120-AR.	3200	240	122.23	3.80	126.03
Sigma 160-ZRS	4000	240	152.79	4.00	156.79
Sigma 160-ZRSD	2300	210	76.87	3.50	80.37
Sigma 160-AR.	4000	240	152.79	4.20	156.99

Maintenance

Maintenance instructions for THK and Rexroth rail guide

For all guide carriage sizes, the relubrication interval is approx. 5000 km for the carriage with ball chain or approx. 2000 km for the carriage without (Rexroth without ball chain / standard). It is dependent on several factors, i.e. operating temperature, load, degree of pollution, etc. Grease quantity depends on the guide carriage (see Table).

Size		12	15	20	25	30	35
Guide		THK					
Quantity	[cm ³]	0.14	0.4	0.6	1.2	1.5	1.7
Guide		Rexroth					
Quantity	[cm ³]	0.15	0.8	1.4	2.8	4.4	4.4

Klüberplex BE 31-102 is used for the initial lubrication. (When using other roller bearing greases, please take note of the manufacturer's instructions!) Roller bearing greases with a solid lubricant percentage (e.g. graphite or MoS₂) is not to be used.

Please refer here to our assembly and maintenance instructions.

Maintenance instructions for roller guide

Under normal operating conditions (dry environment, no dust, etc.), the roller guide is lubricated for life by integrated lubricating felts.

Maintenance instructions for ball screw

For ball screws, relubrication intervals depend on the pitch and the spindle diameter:

KGT 12xx to 32xx after approx. 2.5×10^7 overrolling movements

KGT 40xx and 50xx after approx. 1.5×10^7 overrolling movements

KGT-Type	[Size]	1205	1210	1605	1610	1620	1640	2005	2010	2020	2050	2505	2510	2525	2550
Quantity	[cm ³]	0,55	0,55	1,70	1,80	1,70	1,80	2,00	2,10	2,30	4,50	2,60	3,40	3,10	4,80

KGT-Type	[Size]	3205	3210	3220	3232	3240	3260	4005	4010	4020	4040	5010	5020
Quantity	[cm ³]	4,20	5,60	4,60	5,30	3,00	4,60	5,30	15,40	10,20	14,30	25,90	26,50

Klüberplex BE 31-102 is used for the initial lubrication. (When using other roller bearing greases, please take note of the manufacturer's instructions!) Roller bearing greases with a solid lubricant percentage (e.g. graphite or MoS₂) is not to be used.

In general, ball screw spindles should be protected against contamination. A cover band (standard) or a bellows can be used here.

Please refer here to our assembly and maintenance instructions.

Note: PRESSOL 12226 (125 cm³) one-hand grease gun with spout and corresponding coupler can be ordered from us.

Other maintenance instructions

The relubrication interval and the relubrication amount are generally influenced by many factors (e.g. speed, temperature, ambient conditions, etc.). For this reason, only reference values have been given here. Relubrication should take place at least every two years.

The relubrication should take place "in motion".

Note: The customer is required to carry out a basic lubrication after commissioning!

All mounted ball bearings are sealed and maintenance-free.

The toothed belt is also maintenance-free and must only be replaced if an excess load leads to the breakage or elongation of the elastic area.

Excessive dust and contamination on the toothed belt and at the cover band should be regularly removed.

Chapter K

Ball Screws

HSB-kgt[®]



Rolled ball screw spindles

- Ball screw spindles from reputable manufacturers (some made specially for HSB)
- Small rotating parts ensure a high dynamic response and smooth running.
- Accuracy classes: Standard T7 (52 µm/300 mm), optionally T5 (23 µm/300 mm) (the most sizes)
- Standard length 5600 mm; jointed spindles for greater lengths available on request

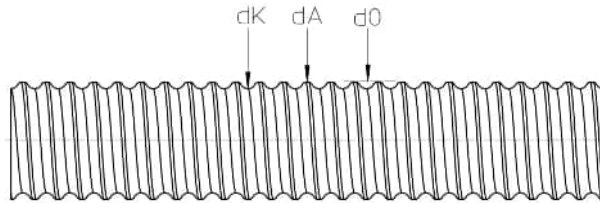

Nominal \varnothing d0 [mm]	Nominal pitch p [mm]	Outer \varnothing [0/-0,2] dA [mm]	Core \varnothing dK [mm]	Number of starts	Ball \varnothing Dw [mm]	Max. length [mm]	Specific weight [kg/m]	Cross section area [mm ²]	Minimum axial area moment of inertia [mm ⁴]	Mass moment of inertia [kg m ²]
12 05		11.5	10.1	1	2.0	3000	0.76	96,4	689	101
12 10		11.5	10.1	2	2.0	3000	0.75	96,1	659	99
16 05		15.4	13.0	1	3.0	5600	1.25	161	2003	295
16 10		15.4	13.0	2	3.0	5600	1.29	160	1691	304
16 20		15.4	13.0	4	3.0	5600	1.24	159	2043	294
16 40		15.0	12.6	4	3.0	5600	1.23	159	2038	277
20 05		19.5	16.9	1	3.5	5600	2.05	261	5392	780
20 10		19.5	16.9	2	3.5	5600	2.00	260	4607	761
20 20		19.5	16.9	4	3.5	5600	2.16	259	5406	821
20 50		19.1	16.5	5	3.5	5600	2.19	262	5522	799
25 05		24.5	21.9	1	3.5	5600	3.81	425	14279	2287
25 10		24.5	22.0	2	3.5	5600	3.39	425	12665	2035
25 25		24.5	22.0	5	3.5	5600	3.44	423	14365	2065
25 50		24.1	21.5	5	3.5	5600	3.48	429	14765	2021
32 05		31.5	28.9	1	3.5	5600	5.73	717	40769	5686
32 10		31.5	29.0	2	3.5	5600	5.54	716	37052	5497
32 20		31.5	28.9	4	3.5	5600	5.81	716	40959	5776
32 40		30.9	28.3	4	3.5	5600	5.51	717	41035	5261
32 60		31.0	28.4	6	3.5	5600	5.66	721	41485	5439
40 10		38.0	33.8	1	6.0	7500	8.25	1036	83224	11913
40 20		38.0	33.8	2	6.0	7500	7.99	1035	75178	11538
40 40		38.0	33.8	4	6.0	7500	8.38	1031	85371	12101

Cylindrical ball screw nuts HSB (KGM-M)

- Uniform design; for each nominal diameter all nuts have the same outer diameter, drive key slots and centring
- Lubrication can be performed via the drive key and lubrication groove
- Newly developed ball recirculation cover with optimised recirculation geometry for high operating speeds
- Made of the best materials and to the highest precision for optimum running characteristics and high load ratings
- Double nut units (KGM-MM) with predefined pre-load (3 %, 5 % or 7 % of the dynamic load rating)

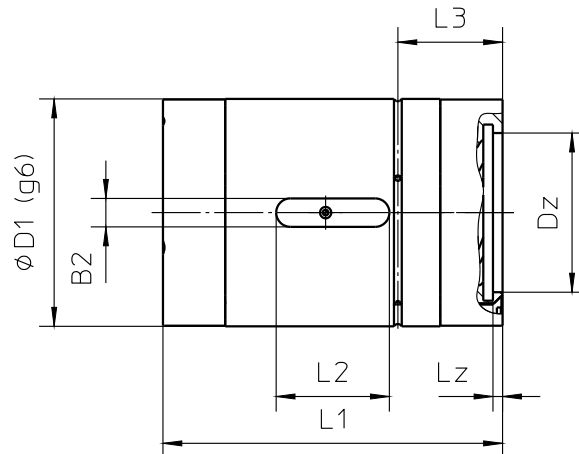

Nominal Ø	Pitch	Outer ø D1 [mm]	Overall length L1 [mm]	Lubrication groove L3 [mm]	Number of starts	Drive key slots			Centring		Load rating	
						B2 x	L2 x	T	Dz	Lz	C0 [kN]	C [kN]
12	05	24	26	11.00	1	3	6	1.5	13.0	3	5.6	3.8
	10	24	26	10.00	2	3	6	1.5	13.0	1.2	6.8	4.3
16	05	28	34	12.60	1	5	10	2	17.5	1.5	16.9	10.5
	10	28	45	16.25	2	5	10	2	17.5	1.5	24.5	14.3
	20	28	34	14.00	4	5	10	2	17.5	1.5	13.0	8.1
	40	28	45	14.50	4	5	10	2	17.5	0.5	13.0	8.5
20	05	35	34	13.00	1	5	10	3	23.0	2	25.4	14.6
	10	35	34	13.00	2	5	10	3	23.0	1.6	23.4	13.5
	20	35	34	13.00	4	5	10	3	23.0	2	19.8	11.5
	20 (lang)	35	54	15.00	4	5	20	3	23.0	2	46.6	23.9
	50	35	56	15.00	5	5	20	3	23.0	2	24.6	12.3
25	05	40	35	13.38	1	5	10	3	28.0	2.4	31.8	16.1
	05 (lang)	40	45	13.38	1	5	20	3	28.0	2.4	49.0	23.3
	10	40	35	13.40	2	5	10	3	28.0	2	29.7	15.1
	10 (lang)	40	45	13.40	2	5	20	3	28.0	2	46.8	22.3
	25	40	35	13.40	5	5	10	3	28.0	0.8	32.2	15.8
	25 (lang)	40	60	19.00	5	5	20	3	28.0	0.8	75.1	32.7
32	05	50	45	13.60	1	6	20	3	35.0	2.1	63.6	26.2
	10	50	60	17.20	2	6	20	3	35.0	2	83.8	33.1
	20	50	55	15.50	4	6	20	3	35.0	2.1	75.9	30.2
	40	50	50	13.60	4	6	20	3	35.0	2.1	35.2	15.2
	60	50	65	18.00	6	6	20	3	35.0	2.2	46.8	18.4
40	10	63	70	19.75	1	6	30	2.5	44.0	1.5	95.2	44.8
	20	63	80	21.00	2	6	30	2.5	44.0	1.5	104.8	48.0
	40	63	95	21.00	4	6	30	2.5	44.0	1.5	142.8	61.6

¹ To ISO 3408-5 (formerly DIN 69051-4)

Ball screw flanged nuts HSB (KGM-F) (to ISO 3408-2 / DIN 69051-5)

- All connection dimensions to ISO3408 / DIN 69051, for easy adaptation
- Newly developed ball recirculation cover with optimised recirculation geometry for high operating speeds
- Made of the best materials and to the highest precision for optimum running characteristics and high load ratings
- Double nut units (KGM-FM) with predefined pre-load (3 %, 5 % or 7 % of the dynamic load rating)



Nominal Ø	Pitch	Outer ø D1 [mm]	Total length L [mm]	Number of Starts	Centring length L1 [mm]	Projection L3 [mm]	Flange thickness L7 [mm]	Width across flats L8 [mm]
12	05	24	26	1	2.75	8.63	6	26
	10	24	26	2	6.50	6.75	6	26
16	05	28	34	1	4.50	9.75	10	40
	10	32	45	2	13.45	10.75	10	40
	20	32	34	4	3.00	11.50	8	40
	40	32	45	4	10.00	10.00	10	40
20	05	36	34	1	4.75	10.63	8	44
	10	36	34	2	3.50	11.25	8	44
	20	36	34	4	3.00	11.50	8	44
	20 (long)	36	54	4	10.00	11.50	10	44
	50	36	56	5	10.00	12.00	10	44
25	05	40	35	1	2.75	11.13	10	48
	05 (long)	40	45	1	12.75	11.13	10	48
	10	40	35	2	3.50	11.75	8	48
	10 (long)	40	45	2	11.50	11.75	10	48
	25	40	35	5	3.00	11.00	10	48
	25 (long)	40	60	5	10.00	11.00	10	48
	50	40	58	5	10.00	13.00	10	48
32	05	50	45	1	10.25	11.38	12	62
	10	50	60	2	19.70	14.15	12	62
	20	50	55	4	17.00	13.50	12	62
	40	50	50	4	14.80	11.60	12	62
	60	50	65	6	15.00	13.50	12	62
40	10	63	70	1	21.50	17.25	14	70
	20	63	80 (100)	2	15.0 (20.0)	18.50	14	70
	40	63	95	4	20.00	18.50	14	70

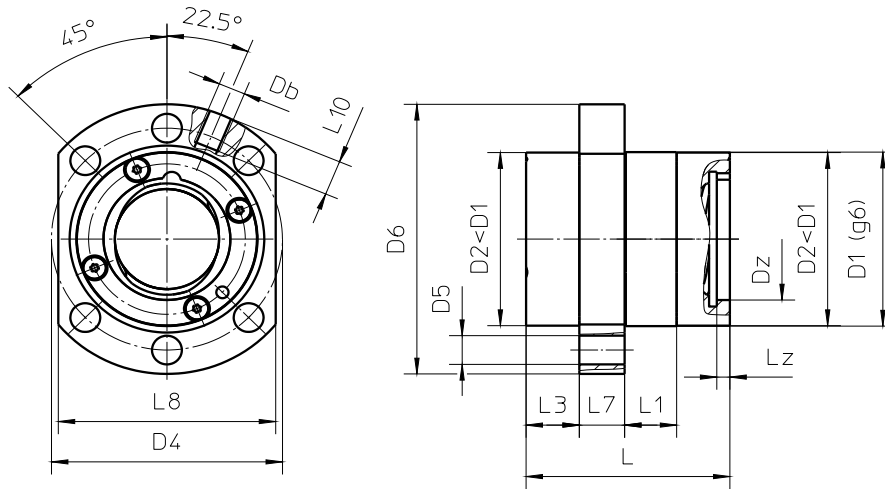

Pitch circle ø D4 [mm]	Attachment hole D5 [mm]	Flange ø D6 [mm]	Hole ø Db	Centring		Load rating ¹	
				Dz	Lz	stat. C0 [kN]	dyn. C [kN]
32	4.5	40	-	13.0	3.0	5.6	3.8
32	4.5	40	-	13.0	1.2	6.8	4.3
38	5.5	52	M6	17.5	1.5	19.9	12.8
42	5.5	52	M6	17.5	1.5	24.4	14.3
42	5.5	52	M6	17.5	1.5	13.0	8.1
42	5.5	52	M6	17.5	0.5	13.0	8.5
47	6.6	58	M6	23.0	2.0	25.4	14.6
47	6.6	58	M6	23.0	1.6	23.4	13.5
47	6.6	58	M6	23.0	2.0	19.8	11.5
47	6.6	58	M6	23.0	2.0	46.6	23.9
47	6.6	58	M6	23.0	2.0	24.6	12.3
51	6.6	62	M6	28.0	2.4	31.8	16.1
51	6.6	62	M6	28.0	2.4	49.0	23.3
51	6.6	62	M6	28.0	2.0	29.7	15.1
51	6.6	62	M6	28.0	2.0	46.8	22.3
51	6.6	62	M6	28.0	0.8	32.2	15.8
51	6.6	62	M6	28.0	0.8	75.1	32.7
51	6.6	62	M6	28.0	1.5	31.6	14.5
65	9.0	80	M6	35.0	2.1	63.6	26.2
65	9.0	80	M6	35.0	2.0	83.8	33.1
65	9.0	80	M6	35.0	2.1	75.9	30.2
65	9.0	80	M6	35.0	2.1	35.2	15.2
65	9.0	80	M6	35.0	2.2	46.8	18.4
78	9,0	93	M8x1	44.0	1.5	95.2	44.8
78	9,0	93	M8x1	44.0	1.5	104.8 (150.7)	48 (65.6)
78	9,0	93	M8x1	44.0	1.5	142.8	61.6

¹ To ISO 3408-5 (formerly DIN 69051-4)

Double nuts HSB (KGM-MM and KGM-FM)

- Double nuts are made by a combination of 2 single nuts; either 2 cylindrical nuts (MM) or one flanged nut and one cylindrical nut (FM)
- The pre-load can be selected by the customer as 3 %, 5 % or 7 % of the dynamic load rating of the ball screw nut

• **Cylindrical double nut KGM-MM**

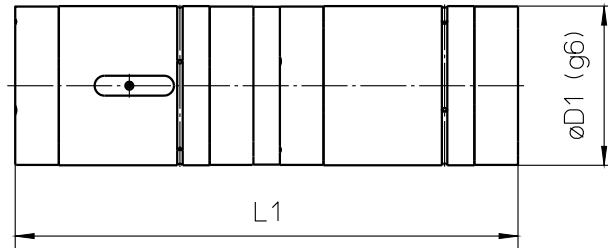

• **Flanged double nut KGM-FM**

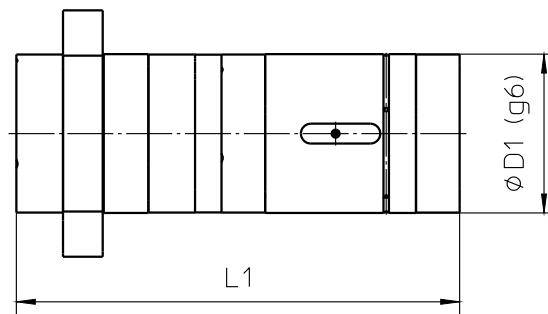

Nominal Ø	Pitch	Outer ø D1 [mm]	Total length L1 [mm]	Number of Starts
16	05	28 / 32 *	74	1
	10	28 / 32 *	96	2
	20	28 / 32 *	74	4
20	05	35	73	1
	10	35	73	2
	20	35	73	4
	20 (long)	35	113	4
25	05	40	77.5	1
	05 (long)	40	97.5	1
	10	40	77.5	2
	10 (long)	40	97.5	2
	25	40	77.5	5
	25 (long)	40	127.5	5
32	05	50	95	1
	10	50	125	2
	20	50	115	4

The remaining technical data are the same as for single nuts.

* KGM-MM Ø 28
KGM-FM Ø 32

Standard end machining for floating bearings and fixed bearings

The bearing arrangement and hence also the spindle end is a significant factor for the quality of the ball screw. This applies particularly in respect of torsional vibration and buckling characteristics of the drive.

We list below our standard ends for our ball screws. In some cases these are turned directly on to the end of the ball screw spindle (form A); or if a larger spindle diameter is required are also bonded on using a modern high-strength adhesive process (form B).

Customer-specific shaft ends to the customer's drawing are available on request.

Standard spindle end Form A

Spindle end is annealed, shaft end is turned

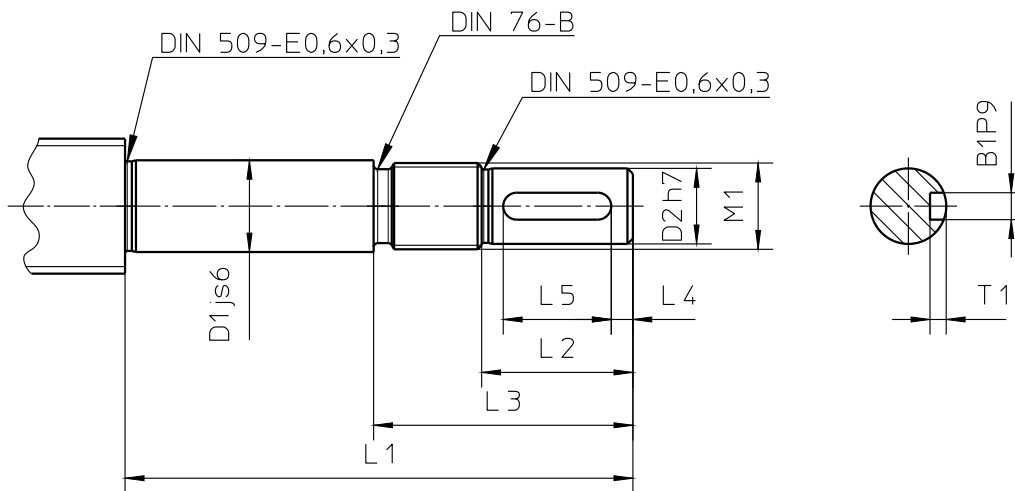

Spindle nominal diameter	D1 [mm]	D2 [mm]	M1	L1 [mm]	L2 [mm]	L3 [mm]	L4 [mm]	L5 [mm]	B1 [mm]	T1 [mm]
20	15	12	14x1.5	76	24	42	3	14	4	2.5
	15	12	14x1.5	78	24	41	3	14	4	2.5
	17	14	16x1.5	94	28	48	4	20	5	3
25	17	14	16x1.5	94	28	48	4	20	5	3
	20	16	18x1.5	104	30	50	4	20	5	3
32	25	20	24x1.5	110	33	52	4	25	6	3.5
	25	20	24x1.5	116	31	53	4	25	6	3.5

(shaft ends with non-standard parameters or to customer's drawing on request.)

Standard spindle end Form B

The spindle end is bonded to the spindle with a high-strength adhesive joint

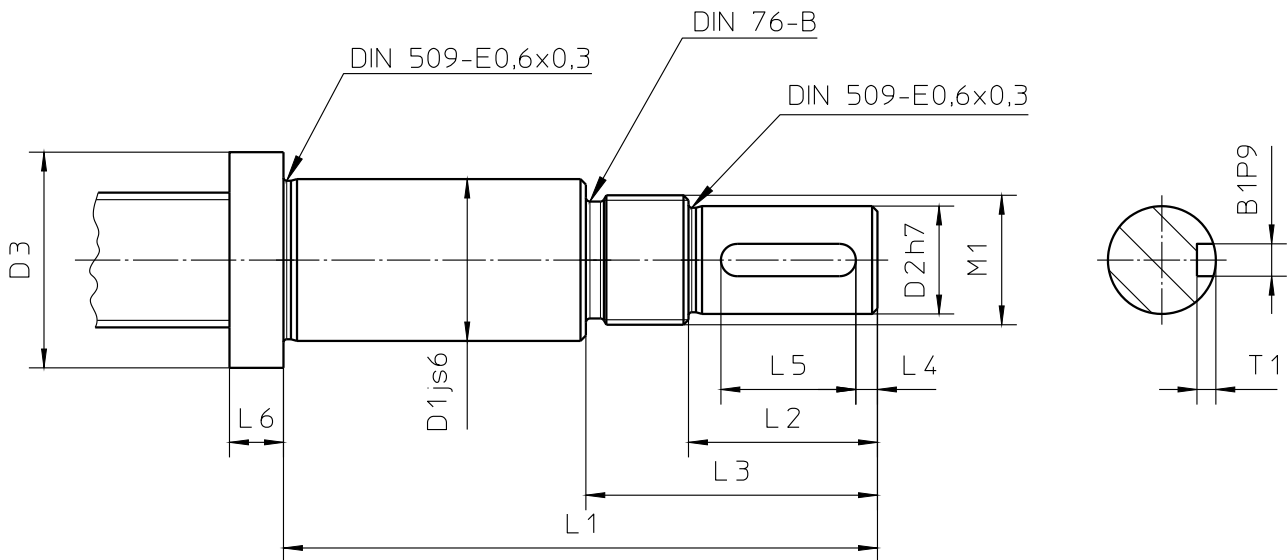

Spindle nominal diameter	D1 [mm]	D2 [mm]	D3 [mm]	M1	L1 [mm]	L2 [mm]	L3 [mm]	L4 [mm]	L5 [mm]	L6 [mm]	B1 [mm]	T1 [mm]
12 ²	10	8	14	10x1	67	20	32	3	14	3	2	1.2
16 ²	15	12	20	14x1.5	69	20	36	3	14	16	4	2.5
	25	14	28	24x1.5	89	30	50	4	20	4	5	3
20	25	16	32	24x1.5	104	30	50	4	20	12	5	3
25	30	20	40	24x1.5	110	35	54	4	25	10	6	3.5
32 ²	30	24	40	28x1.5	126	51	74	5	30	9	8	4
	40	24	50	35x1.5	134	41	67	5	30	12	8	4

² The stub end is machined prior to bonding to the spindle.

(shaft ends with non-standard parameters or to customer's drawing on request.)

Standard spindle end form C

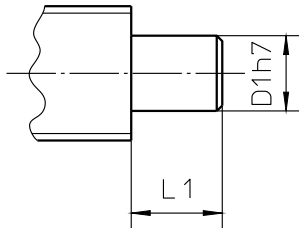

Spindle nominal diameter	D1 [mm]	L1 [mm]
12	5	7
16	8	9
20	12	9.5
	15	13
25	15	14
32	15	14
	25	17

(shaft ends with non-standard parameters or to customer's drawing on request.)

Standard spindle end form X

Separate and chamfered

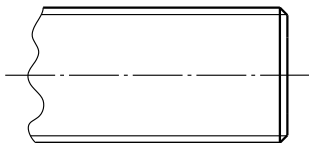

Standard spindle end Form G

Spindle end separate and annealed

Ordering example:

KGT-FM - 2510 - RH - T7 - B120 - 1334 - G60 - V3 - 0

Product

- KGT-M = ball screw with cylindrical single nut
- KGT-F = ball screw with flanged single nut
- KGT-MM = ball screw with cylindrical double nut
- KGT-FM = ball screw with flanged double nut
- KGM-M = cylindrical ball screw single nut
- KGM-F = flanged ball screw single nut
- KGM-M = cylindrical ball screw double nut
- KGM-FM = flanged ball screw double nut
- KGS = ball screw spindle

Nominal diameter [mm]

Nominal pitch [mm]

Pitch sense

- RH = right-hand screw (standard)
- LH = left-hand screw (on request)

Pitch accuracy

- T7 = 52 µm/300 mm (standard)
- T5 = 23 µm/300 mm (on request)

Spindle end fixed bearing

- A, B, C = standard end (page K6 ff.)
- X = separate
- G = annealed
- K = to customer's drawing

Length of spindle end for fixed bearing

Overall length of the spindle

Spindle end floating bearing

- A, B, C = standard end (page K6 ff.)
- X = separate
- G = annealed
- K = to customer's drawing

Length of spindle end for floating bearing

Play / pre-load ¹

- | | | |
|--------------------|--|---------------------------|
| S2 = standard play | pitch 5 mm and 10 mm | ⇒ approx. 0.04 to 0.06 mm |
| | Pitch 20 mm and 25 mm | ⇒ approx. 0.06 to 0.08 mm |
| | Pitch 40 mm and larger | ⇒ approx. 0.08 to 0.15 mm |
| S1 = low play | pitch 5 mm and 10 mm | ⇒ approx. 0.02 mm |
| | Pitch 20 mm and 25 mm | ⇒ approx. 0.02 to 0.04 mm |
| | Pitch 40 mm and larger | ⇒ approx. 0.03 to 0.08 mm |
| S0 = free of play | no free play, very small pre-load | |
| V3 = 3 % pre-load | } (in relation to the dynamic load rating) | |
| V5 = 5 % pre-load | | |
| V7 = 7 % pre-load | | |

Special version

- 0 = standard version
- 1 = customer-specific version, after discussions with our sales staff (e.g. Pitch accuracy 23 µm/300 mm [T5] or similar)

¹ For single nuts without spindle (KGM-M, KGM-F) only standard play is available.

Chapter TK

Technology

Ball Screw

HSB-kgt[®]

General technical specification

Manufacturing processes

HSB ball screw spindles are made by the cold rolling process, then heat treated and polished. HSB ball screw nuts are first machined in the soft condition, then heat treated and finish machined in a modern hard turning process. Both spindles and nuts are finished to a gothic arch profile. The ball contact angle is 45° (±5°).

Speeds

The generally permitted speed limit is 3000 rpm. On request, for certain sizes and installation situations, speeds up to 4500 rpm are permissible. The speed limits are the maximum speeds, achievable only under ideal operating conditions. The critical speed must always be taken into account. The achievable speed is calculated as follows:

$$\frac{\text{Permissible speed} \cdot \text{Pitch}}{60000} \left[\frac{\text{m}}{\text{s}} \right]$$

Installed length

The installed length of a ball screws is generally freely selectable. Ball screws transmit only axial forces. All radial forces that arise must be accepted by external guides, otherwise they may cause the ball screw to fail prematurely.

Accuracy

HSB ball screw spindles are available in the following accuracy classes:

T5 = Pitch accuracy 23 µm/300 mm

T7 = Pitch accuracy 52 µm/300 mm

Unless specified otherwise, we supply class T7.

Self-locking

Due to their low rolling resistance, ball screws do not self-lock.

Therefore it is necessary, particularly when the ball screw shaft is mounted vertically, to employ a suitable motor with a restraining brake.

Efficiency

For trapezoidal screws, the mechanical efficiency is generally below 50 %; for ball screws however it is up to 98 %.

Duty cycle

The ball screw is capable of maintaining a duty cycle of up to 100 %. It is best to avoid extremely high loadings in combination with high duty cycles.

Temperatures

All ball screws are designed for ambient temperatures from 0 °C to 80 °C. Temperatures of a minimum of -20 °C and maximum of 110 °C are also permissible for brief periods. Ball screws are subject to certain restrictions when used at temperatures below freezing. In addition, the specifications provided by the lubricant supplier must be complied with.

Positioning accuracy, repetition accuracy, backlash

Positioning accuracy is the maximum deviation between instructed position and actual position.

Repetition accuracy is defined as the capability of the system, under the same conditions, to return to a position it had previously taken up.

Backlash describes the “dead space” between the parts that are moved.

Aggressive operating conditions

Under very large amounts of dirt and/or fine dust/chips, the customer is advised to take measures to shield the ball screw.

Technical Data

Ball screw spindle KGS

- Thread: Gothic arch profile
- Nominal diameter: 12 – 40 mm
- Pitch: 5 – 60 mm
- Number of starts: 1 – 6
- Direction of rotation: right-hand
- max. length: 5600 mm
- Material: 1.1213 (Cf 53)
- Bearing track induction hardened and polished
- Spindle end and spindle core are soft
- Straightness: L < 500 mm: 0.05 mm/m
L = 500 – 1000 mm: 0.08 mm/m
L > 1000 mm: 0.1 mm/m
- End machining: to customer's specification

Critical bending speed

Critical bending speed is the speed at which the forces of rotational imbalance initiate resonant vibration of the spindle. The cause of this imbalance is the sag of the ball screw spindle under its own weight. The critical bending speed is similar to the buckling load in that its value depends on the bearings of the ball screw spindle. For this purpose both the fixed bearing and also the floating bearing can be assumed to be rigid or non-rigid. These assignments yield 4 possible variants.

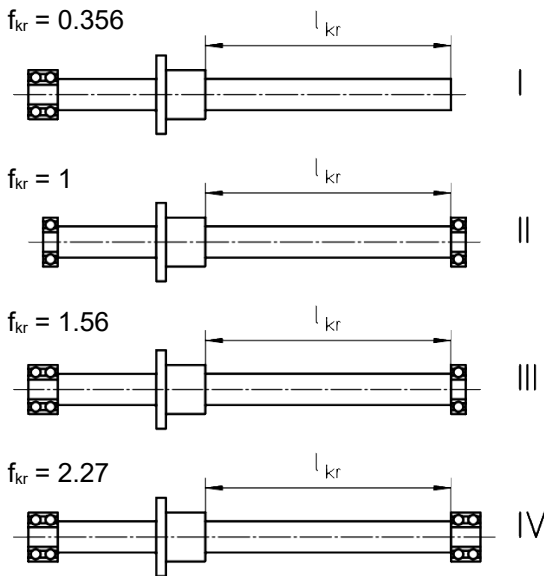

Critical speed:

$$n_{kr} = 1,08 \cdot 10^8 \cdot f_{kr} \cdot \frac{d}{l_{kr}^2}$$

wit h $d = \frac{d_A + d_K}{2}$

n_{kr} [rpm]
 d, d_A, d_K [mm]
 L_{kr} [mm]

The permissible speed must not be greater than a maximum of 80 % of the critical speed.

Permissible speed:

$$n_{zul} = 0,8 \cdot n_{kr}$$

Critical buckling load

For slender components there is a risk of lateral buckling under axial forces. The procedure described below allows the permissible axial force to be determined for four different support bearing cases, using Euler's method. Allowance should always be made of machine-specific safety factors.

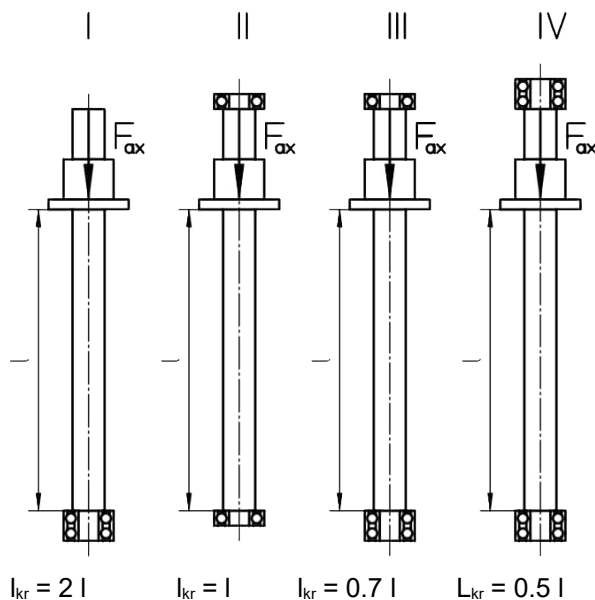

Critical buckling load:

$$F_{kr} = 1,017 \cdot 10^5 \cdot \frac{d_2^4}{l_{kr}^2}$$

F_{kr} [N]
 d_2 [mm]
 l_{kr} [mm]

Working life calculation

The nominal theoretical working life of a ball screw is calculated by a method similar to that for calculating the working life of a ball bearing. It should be noted that vibration and shock loads adversely affect the working life of the ball screw. Radial loadings are not permitted.

Average speed:

$$n_m = \frac{n_1 \cdot q_1 + n_2 \cdot q_2 + \dots + n_i \cdot q_i}{100}$$

- n_m ... Average speed in [rpm]
- $n_1, n_2 \dots$ Speeds in [rpm] during the interval q_1, q_2, \dots
- $q_1, q_2 \dots$ Proportions of the duration of loaded operation in one direction of loading in [%]

Dynamic equivalent axial load:

$$F_m = \sqrt[3]{F_1^3 \cdot \frac{n_1 \cdot q_1}{n_m \cdot 100} + F_2^3 \cdot \frac{n_2 \cdot q_2}{n_m \cdot 100} + \dots + F_i^3 \cdot \frac{n_i \cdot q_i}{n_m \cdot 100}}$$

- $F_1, F_2 \dots$ Axial loads in [N] in one direction of loading during the interval q_1, q_2, \dots
- $F_m \dots$ Dynamic equivalent axial load
Since a ball screw can be loaded in either of two directions, F_m is first determined for each of the two directions of loading. The larger value is then used in the calculation of L.
In general it is useful to create the following structure:

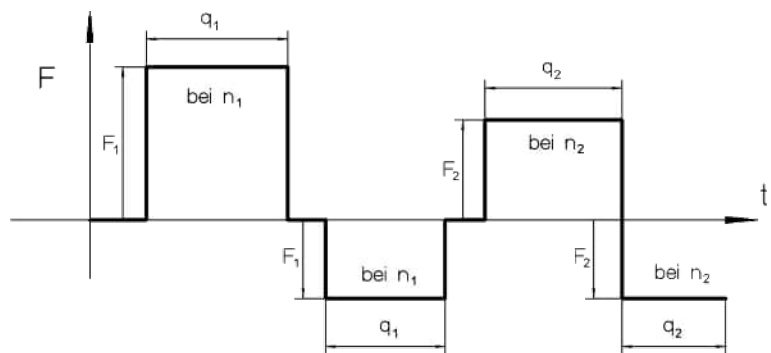

It should be remembered that a pre-load represents an ever-present additional load.

Theoretical working life:

$$L_{10} = \left(\frac{C}{F_m}\right)^3 \cdot 10^6$$

- C ... Dynamic load rating
Centrally applied load in [N], of unchangeable value and direction, for which a sufficiently large number of identical ball screws each achieves a nominal working life of 10^6 revolutions.
- L_{10} ... Working life of the ball screw. Expressed as the number of overrollings which are reached or exceeded by 90 % of a sufficiently large number of apparently identical ball screws before the first signs of material fatigue appear.

(Working life in metres: L_{10} multiplied by the pitch, divided by 1000)

Efficiency and torque

The efficiency depends on many operating influences, as well as the geometrical values. In practice therefore the actual values may vary by $\pm 5\%$ from the theoretically determined values.

Conversion of a rotary movement into a longitudinal movement:

Efficiency η

$$\eta = \frac{\tan \phi}{\tan(\phi + \rho)} \quad \text{with} \quad \tan \phi = \frac{P_0}{d_0 \cdot \pi}$$

Drive torque M_A

$$M_A = \frac{F_A \cdot P_0}{2000 \cdot \pi \cdot \eta}$$

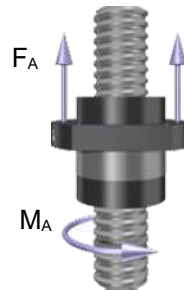

Conversion of a longitudinal movement into a rotary movement:

Efficiency η'

$$\eta' = \frac{\tan(\phi - \rho)}{\tan \phi} \quad \text{with} \quad \tan \phi = \frac{P_0}{d_0 \cdot \pi}$$

Output torque M_a

$$M_a = \frac{F_a \cdot P_0 \cdot \eta'}{2000 \cdot \pi}$$



η, η' ...	Efficiency of the ball screw	[-]
ρ ...	Friction angle (0.34° for tolerance classes T5 + T7)	[$^\circ$]
Φ ...	Pitch angle	[$^\circ$]
P_0 ...	Nominal pitch of the ball screw	[mm]
d_0 ...	Nominal diameter of the ball screw	[mm]
M_A ...	Drive torque	[Nm]
M_a ...	Output torque	[Nm]
F_A ...	Result axial force	[N]
F_a ...	Effective axial force	[N]

Installation

The installation of ball screws demands technical knowledge and appropriate measuring equipment. Due to the low friction of a ball screw, alignment errors when turning the screw by hand are generally imperceptible. Forces acting radially or eccentrically must be taken up by the external guides. Ball screws can absorb only axial forces. In order to prevent damage to the ball screw, the machine must be provided with limit switches and end of travel dampers.

Cover

Any contamination that occurs during installation should be removed using kerosene, oil or benzine. Cold cleaning solvents and paint solvents are not permissible. Ball screws must be protected from dust, swarf and the like during operation, even if they are equipped with wipers.

Protective measures that can be taken are as follows:

- Bellows (if not equipped with an additional guide these are permissible only for vertical installations)
- Spiral spring cover
- Telescopic tubes or sleeves (large axial space requirement)

Our range also includes fully protected and ready-to-install systems:

- HSB-beta®, HSB-delta® and HSB-alpha® linear guides providing integral guidance within an encapsulated aluminium profile with covering strip or covering bellows. Please request our documents.

Lubrication

Correct lubrication is important in order that the ball screw achieves its calculated service life, to prevent excessive heating and to guarantee smooth, quiet running. KGT uses the same lubricants as are used for roller bearings.

Oil mist lubrication

If central lubrication using oil mist is in operation, make sure that only ball screw nuts without wipers are used.

Oil lubrication

The oil quantities that are supplied must not exceed the application losses at the wipers (otherwise the result is circulating oil lubrication).

Type of oil: Viscosity 25 to 100 mm²/s at 100 °C.

Grease lubrication

For ball screws, lubrication intervals depend on the pitch and the spindle diameter: Lubrication is determined by whether grease is emerging from the wipers (under normal operating conditions every $2.5 \cdot 10^7$ overrollings*). Because the grease does escape, we find by experience that a lifetime fill of lubrication is not sufficient.

Types of grease:

Roller bearing grease without any element of solid lubricant

The first filling must be with KLÜBERPLEX BE31-102 NLGI2 roller bearing grease to DIN 51818.

Detailed data on the amounts of grease and lubrication intervals can be found in the "Installation and Maintenance Manual" as well as on the Internet under www.hsb-automation.de.

* $\hat{=}$ Revolutions of the spindle

KGT- Type	Lubrication amount [ml]	
	Standard	Long
1205	0,6	-
1210	0,6	-
1605	1,7	-
1610	1,8	-
1620	1,7	-
1640	2,3	-
2005	2,0	-
2010	2,1	-
2020	2,3	4,5
2050	4,5	-
2505	2,6	3,9
2510	3,4	5,1
2525	3,1	5,4
2550	4,8	-
3205	4,2	-
3210	5,6	-
3220	4,6	-
3240	3,0	-
3260	3,9	-
4010	10	-
4020	12	15
4040	15	-

Operating temperature

The permissible operating temperature range for ball screws is between 0 °C and +80 °C. A minimum temperature of -20 °C and a maximum temperature of +110 °C are permissible for brief periods. This always assumes lubrication has been carried out correctly.

At temperatures of -20 °C, the torque can increase by a factor of up to 10.

Technical data for the design of linear modules

Date: _____

Data recorded by: _____

Company: _____

Contact: _____

Address: _____

E-mail: _____

Phone: _____

Fax: _____

Application: _____

Sketch, where applicable: _____

Specification:

Transport weight [kg]: _____

Required stroke [mm]: _____

Installed length: horizontal vertical else

Traversing speed [m/sec]: _____

Acceleration [m/sec²]: _____

Cycle time [sec]: _____

Cycles/min: _____

Repeat accuracy [\pm mm]: _____

Carriage plate installation position:
 top bottom side

Lever arm length (catalogue: "Basic principles of determining forces and moments"):

lx [mm]: _____ ly [mm]: _____ lz [mm]: _____

Forces/moments:

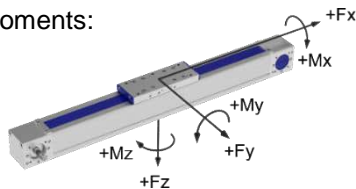

Environmental influences: Dust Chips

Ambient temperature [°C]: _____

Humidity [%]: _____

Accessories:

Fastening:

Sliding blocks (NS____) Number: _____

Mounting bracket (BL____) Number: _____

Limit switch:

mechanical, built-in (type EMB/EMS): Number: _____

inductive, built-in EO2: Number: _____

inductive, built-in EO10: Number: _____

inductive, built-in ES2: Number: _____

inductive, built-in ES10: Number: _____

Limit switch installation position

(Catalogue: Ordering designations for limit switch items...and drive shafts):

	Page	Item a	Item b	Type	Cable side
Switch 1					
Switch 2					
Switch 3					
Switch 4					

Drive shafts:

AZ1 AZ2 AZ6 Other: _____

Motor mounting (type MGK): Yes* No

*Please attach motor dimension sheet

Motor coupling (type GS): Yes* No

*Motor diameter: _____

*Feather key: Yes No

Deflection belt drive: Yes* No

*Mounting position: _____ Gear ratio: _____

*Please attach motor dimension sheet.

Bevel gear: Yes* No

*Gear ratio: _____

Joint shaft GX: Yes* No

* Centre distance: _____ mm between unit size: _____

Handling Systems

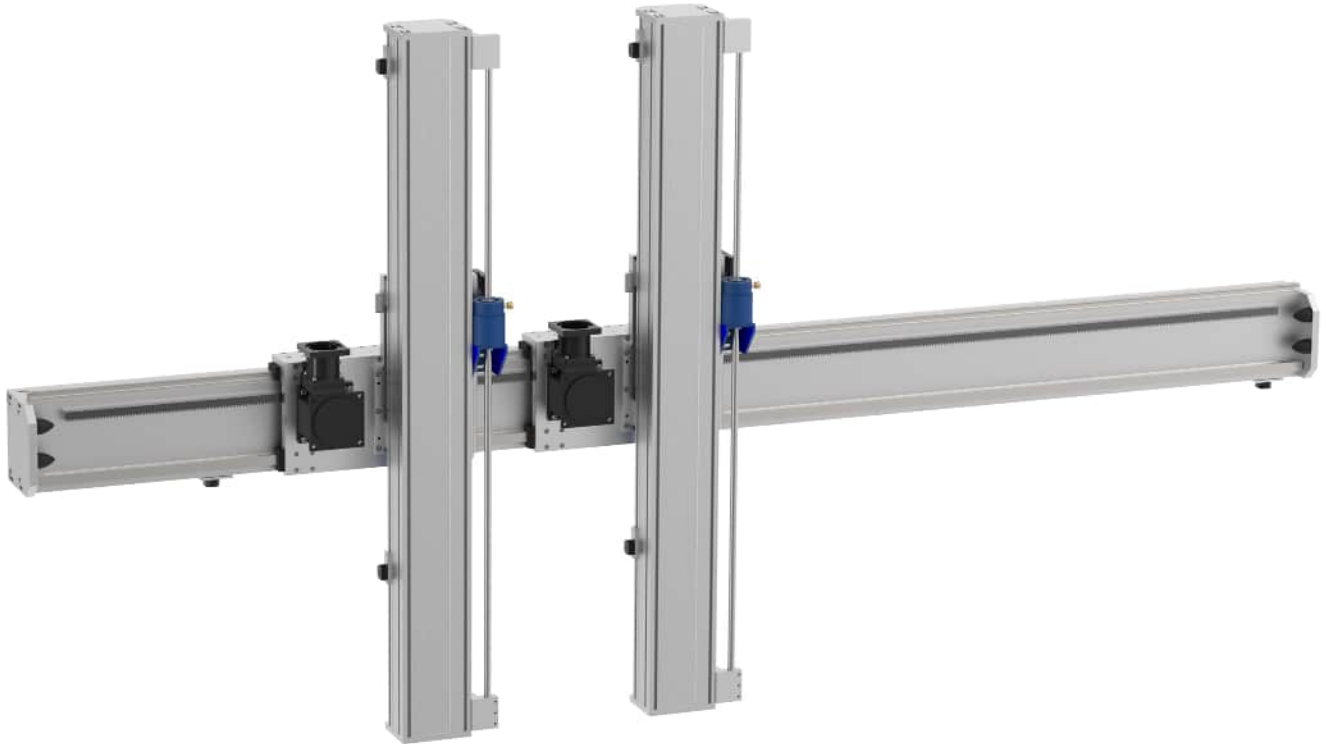

This 2-axis portal system consists of:

1x HSB-gamma[®] 280-AZSS and
2x HSB-gamma[®] 220-AZSH

You can find our worldwide sales on
our website www.hsb-automation.de



HSB Automation GmbH

In Laisen 74, 72766 Reutlingen

phone: +49 7121 14498-0

fax: +49 7121 14498-10

info@hsb-automation.de

